



# MOUNTING BRACKET KIT INSTALLATION INSTRUCTIONS

**KIT# 1427-3**

09/25/07  
RV

ROADMASTER, Inc. 5602 N.E. Skyport Way Portland, OR 97218 1-800-669-9690 Fax (503) 288-8900 www.roadmasterinc.com

ROADMASTER, INC.

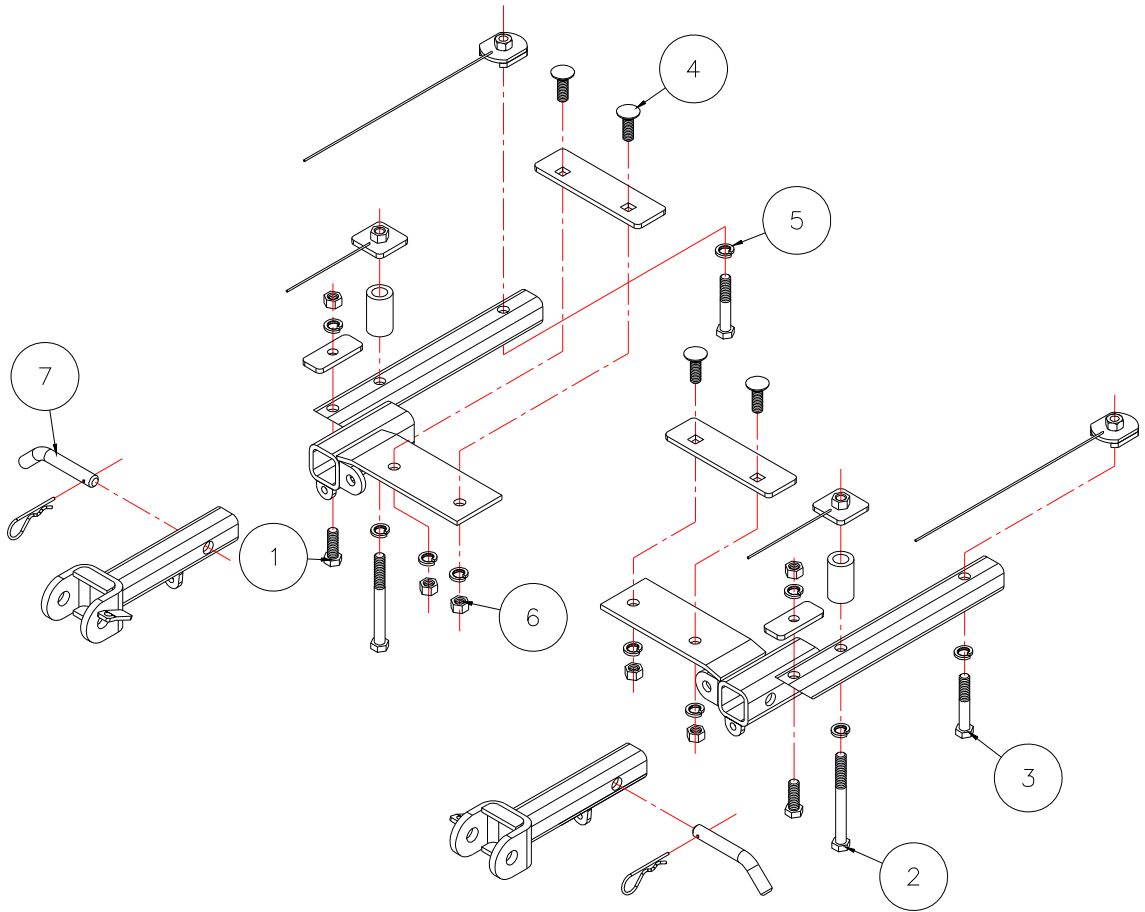

Item	Qty.	Length	Width	Description	Part #
1	2	1 1/2"	1/2"	BOLT	350095-00
2	2	5"	1/2"	BOLT	350107-00
3	2	3"	1/2"	BOLT	350101-00
4	4	1 1/4"	1/2"	CARRIAGE BOLT	350361-00
5	10		1/2"	LOCK WASHER	350309-00
6	6		1/2"	NUT	350258-00
7	2			DRAW PIN/SPRING PIN	357035-00
8	4			PLASTIC POP RIVET	350431-00



# MOUNTING BRACKET KIT INSTALLATION INSTRUCTIONS

**KIT# 1427-3**

09/25/07  
RV

ROADMASTER, Inc. 5602 N.E. Skyport Way Portland, OR 97218 1-800-669-9690 Fax (503) 288-8900 www.roadmasterinc.com

**IMPORTANT:** All brackets *must* be assembled with all the bolts left loose for final adjustment & positioning (before tightening) unless otherwise instructed. All bolts *must* be torqued for proper strength. If more than one bolt is used per fastening point, the diagram may only show one.

- Use flat washers over all slotted holes
- Use lock washers on all fasteners

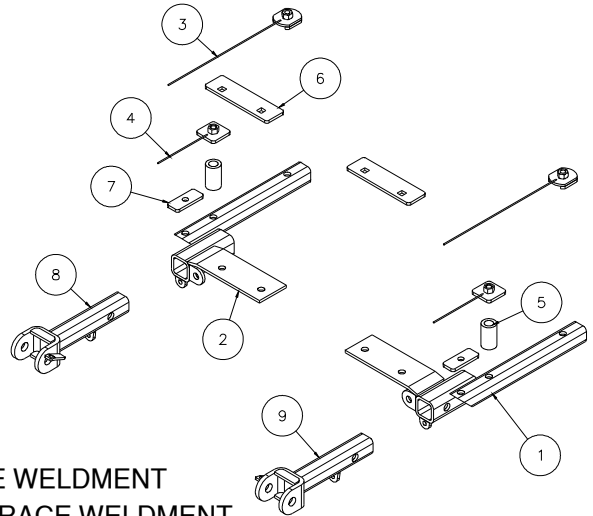

Item	Qty.	Part #	Description
1	1	C-001110	DRIVER SIDE RECEIVER BRACE WELDMENT
2	1	C-001111	PASSENGER SIDE RECEIVER BRACE WELDMENT
3	2	C-001120	REAR NUTTED BACKING PLATE WELDMENT
4	2	C-001121	2" x 2" NUTTED BACKING PLATE
5	2	A-000960	ROUND TUBE - 1 1/4" DIA x 2 1/8" LONG
6	2	A-001784	7" x 2" SQUARE HOLE BACKING PLATE
7	2	A-000317	1/4" x 1 1/4" x 3" BACKING PLATE
8	1	C-001115	PASSENGER SIDE ARM BRACE WELDMENT
9	1	C-001114	DRIVER SIDE ARM BRACE WELDMENT

ROADMASTER Limited Warranty, including One-Year Conditional Warranty Text and Product Registration Card, in Carton.

## WARNING

- Do not use this document for custom fabrication, as it may not show all parts or structural components. Custom fabrication or an attempt to copy this bracket design could result in loss of the towed vehicle.
- The owner must inspect all mounts and brackets before each use for cracks or other signs of fatigue. Also, inspect the fasteners for proper torque, according to the bolt torque requirements chart on the last page. Failure to do so could result in loss of the towed vehicle.
- The owner must check the manufacturer's instructions for the proper procedure(s) to prepare the vehicle for towing. Some vehicles must be equipped with a transmission lube pump, an axle disconnect, driveline disconnect or free-wheeling hubs before they can be towed. Failure to properly equip the vehicle will cause severe damage to the transmission.
- The installer must read the instructions and use all bolts and parts supplied. Failure to securely fasten the bracket could result in loss of the towed vehicle.
- If running changes were made by the vehicle manufacturer after this bracket was designed, some bolts or other fasteners in the included hardware pack may no longer be the correct size. It is the installer's responsibility to verify that the bracket is securely fastened to the vehicle, and fitted with the correct hardware, to account for these changes. Failure to securely fasten the bracket could result in loss of the towed vehicle.
- If the towed vehicle has been in an accident, it must be properly repaired before attaching the bracket. Do not install the bracket if any structural frame damage is found. Failure to repair the damage may result in the loss of the towed vehicle.

- Some motorhome chassis have such a tight turning radius that you can damage your motorhome, towed vehicle, tow bar or bracket while turning sharply. Before getting on the road, test your turning radius in an empty parking lot. Turning too sharply could result in non-warranty damage to towing system, motorhome and/or towed vehicle.
- Do not back up with the towed vehicle attached or non-warranty damage will occur to your towing system, motorhome and/or towed vehicle.
- The safety cables must connect the towing vehicle to the towed vehicle frame to frame, with the cables crossed, with enough slack for sharp turns. Refer to the cable instructions for proper routing. Failure to leave enough slack in the safety cables, or failure to connect the safety cables frame to frame, will result in the loss of the towed vehicle.
- This bracket is designed for use with ROADMASTER tow bars and ROADMASTER adaptors only. Using this bracket with other brands, without an approved ROADMASTER adaptor, may result in non-warranty damage or injury.
- Upon final installation, the installer must inspect the bracket to ensure adequate clearance, particularly around hoses, air conditioner lines, radiators, etc., or non-warranty damage to the towed vehicle will result.
- This bracket is only warranted for the original installation. Installing a used bracket on another vehicle is not recommended and will void the warranty.

## WARNING

Failure to follow these instructions can result in property damage, personal injury or even death.



# MOUNTING BRACKET KIT INSTALLATION INSTRUCTIONS

**KIT# 1427-3**

09/25/07  
RV

ROADMASTER, Inc. 5602 N.E. Skyport Way Portland, OR 97218 1-800-669-9690 Fax (503) 288-8900 www.roadmasterinc.com

## 2005 - 2008 Jeep Grand Cherokee Instructions

This bracket kit fits the 2006 - 2008 Jeep Commander and the 2005 - 2008 Jeep Grand Cherokee. Follow the instructions below for the Jeep Grand Cherokee; for the Jeep Commander, see the separate section included in these instructions.

This is one of our MX series brackets, which allows the visible front portion of the bracket to be easily removed from the front of the vehicle (Fig.A and Fig.B). The bracket kit consists of two receiver braces, two removable front bracket arms, and a hardware pack.

Before starting the installation, lay out the kit components in order as they will be used. This will give you a visual idea of how the components work, and will also confirm that everything is present and accounted for.

1. Start by removing the six plastic fasteners across the top of the grille (Fig.C).
2. Then, remove the grille by pulling straight up.
3. Remove the four plastic fasteners across the top of the fascia (Fig.D). *Note: 2005-2007 models only.*
4. Using a 1/4" drill bit, drill out the center of the two pop rivets (on each side) which hold the fender liner to the fascia (Fig.E). Remove the pop rivets.



5. On each side, remove the 7mm (head) bolt holding the fascia to the top of the fender (Fig.F).
6. At the bottom of the fascia, remove the three 10mm (head) bolts connecting the fascia to the radiator support (Fig.G).
7. Disconnect the fog lights, if the vehicle is so equipped.
8. Remove the fascia by pulling forward slightly from the side.
9. Remove the two frame rail covers to gain access to the inner frame rail by removing one 10mm (head) bolt from each cover (Fig.H).

All illustrations and specifications contained herein are based on the latest information available at the time of publication approval. ROADMASTER, INC. reserves the right to make changes at any time without notice in material, specification and models or to discontinue models.



# MOUNTING BRACKET KIT INSTALLATION INSTRUCTIONS

**KIT# 1427-3**

09/25/07  
RV

ROADMASTER, Inc. 5602 N.E. Skyport Way Portland, OR 97218 1-800-669-9690 Fax (503) 288-8900 www.roadmasterinc.com

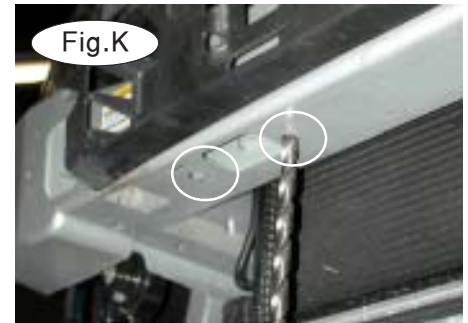

10. Remove the tow hooks, if the vehicle is so equipped, by removing the three 15mm nuts on each side (Fig.I).
11. Next, on each side, bend the retainer clip (Fig.J) on the tow hook studs and remove the tow hook studs.
12. Working on the passenger side, enlarge the two existing holes located on the bottom of the bumper core with a 1/2" drill bit (Fig.K).
13. Place two 1/2" x 1 1/4" carriage bolts into a 2" x 7" backing plate. *Note:* the holes in the backing plate are offset to match the holes in the bumper core. Now, insert the backing plate into the opening between the two holes you enlarged in step 12 (Fig.L) and thread the bolts through the bumper core (Fig.M).

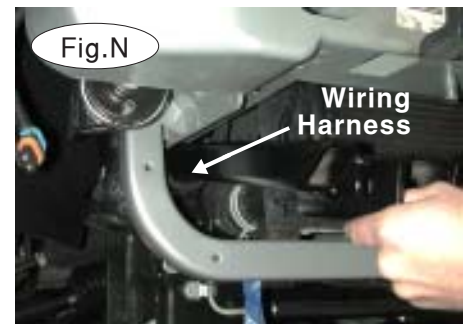

14. Set the receiver brace in place. Insert the rear portion of the brace between the frame rail and the wiring harness (Fig.N – passenger side only).
15. Attach the front of the receiver brace with two 1/2" lock washers and nuts onto the two 1/2" x 1 1/4" carriage bolts you positioned in step 13 (Fig.O). Finger-tighten only at this time.
16. Repeat steps 10 through 15 to attach the front of the driver's side receiver brace.





# MOUNTING BRACKET KIT INSTALLATION INSTRUCTIONS

**KIT# 1427-3**

09/25/07  
RV

ROADMASTER, Inc. 5602 N.E. Skyport Way Portland, OR 97218 1-800-669-9690 Fax (503) 288-8900 www.roadmasterinc.com



17. There are three bolts to hold the rear of each receiver brace in place. First, attach the rear bolt – using the attached wire, move the round backing plate with weld nut through the opening in the front of the frame rail and into position (Fig.P). Thread a  $\frac{1}{2}$ " x 3" bolt and  $\frac{1}{2}$ " lock washer through the hole in the round backing plate and the existing hole in the frame rail.

Finger tighten only at this time. Once the bolt is threaded into the backing plate, use pliers to break the wire off the backing plate (Fig.Q).



18. To attach the center bolt, use the center hole in the receiver brace and the existing hole in the frame rail as a template. With a  $\frac{1}{2}$ " drill bit, drill through the center reinforcement (Fig.R).

19. Insert a  $1\frac{1}{4}$ " x  $2\frac{1}{8}$ " pipe spacer over the hole you just drilled, between the bottom of the frame rail and the center reinforcement (Fig.S).

20. Insert a  $\frac{1}{2}$ " x 5" bolt and  $\frac{1}{2}$ " lock washer through the hole you drilled in step 18, through the main brace, the bottom of the frame rail, the pipe spacer, and the center reinforcement.

21. Using the attached wire, position the 2" x 2" backing plate with weld nut on top of the center reinforcement (Fig.T). Thread the  $\frac{1}{2}$ " x 5" bolt through the 2" x 2" backing plate (Fig.U). Finger tighten only at this time. Once the bolt is threaded into the backing plate, use pliers to break the wire off the backing plate.



# MOUNTING BRACKET KIT INSTALLATION INSTRUCTIONS

**KIT# 1427-3**

09/25/07  
RV

ROADMASTER, Inc. 5602 N.E. Skyport Way Portland, OR 97218 1-800-669-9690 Fax (503) 288-8900 www.roadmasterinc.com



22. To attach the third bolt, insert the 1/2" x 1 1/2" bolt through the receiver brace and the bottom of the frame rail (Fig.V). Finger tighten only at this time.
23. Repeat steps 17 through 22 to attach the rear of the receiver brace to the other side.
24. Torque all bolts to the specifications at the end of these instructions. *Note:* to prevent noise vibration, check the center attachment on the rear of both receiver braces to ensure that all slack between the pipe spacers and the center reinforcements is taken up.
25. Reattach the two frame rail covers you removed in step 9.
26. Reinstall the fascia by reversing steps 1 through 8. *Note:* the hardware kit includes four new plastic pop rivets to reattach the fascia to the fender liners, two for each side (Fig.W).
27. Fit the front bracket arms into the front receiver braces, and secure them in place with the supplied 5/8" draw pins and spring pins.
28. Install the tow bar to the mounting bracket according to the manufacturer's instructions. Attach the safety cables to the main brace.

## BOLT TORQUE REQUIREMENTS

Note: The torque values represented below are intended as general guidelines. Torque requirements for specific applications may vary. Roadmaster does not warrant this information to be accurate for all applications and disclaims all liability for any claims or damages which may result from its use.

### STANDARD BOLTS

Thread Size	Grade	Torque
5/16	5	13 ft./lb.
3/8	5	23 ft./lb.
7/16	5	37 ft./lb.
1/2	5	56 ft./lb.
5/8	5	150 ft./lb.

### METRIC BOLTS

Thread Size	Grade	Plated / Unplated
8mm-1.0	8.8	20 ft./lb. 18 ft./lb.
8mm-1.25	8.8	19 ft./lb. 18 ft./lb.
10mm-1.25	8.8	38 ft./lb. 36 ft./lb.
10mm-1.5	8.8	37 ft./lb. 35 ft./lb.

### METRIC BOLTS

Thread Size	Grade	Plated / Unplated
12mm-1.25	8.8	70 ft./lb. 65 ft./lb.
12mm-1.5	8.8	66 ft./lb. 61 ft./lb.
12mm-1.75	8.8	65 ft./lb. 60 ft./lb.
14mm-2.0	8.8	104 ft./lb. 97 ft./lb.

All illustrations and specifications contained herein are based on the latest information available at the time of publication approval. ROADMASTER, INC. reserves the right to make changes at any time without notice in material, specification and models or to discontinue models.



# MOUNTING BRACKET KIT INSTALLATION INSTRUCTIONS

**KIT# 1427-3**

09/25/07  
RV

ROADMASTER, Inc. 5602 N.E. Skyport Way Portland, OR 97218 1-800-669-9690 Fax (503) 288-8900 www.roadmasterinc.com

## 2006-2008 Jeep Commander Instructions

This bracket kit fits the 2006 - 2008 Jeep Commander and the 2005 - 2008 Jeep Grand Cherokee. Follow the instructions below for the Jeep Commander; for the Jeep Grand Cherokee, see the separate section included in these instructions.

This is one of our MX series brackets, which allows the visible front portion of the bracket to be easily removed from the front of the vehicle (Fig.A and Fig.B). The bracket kit consists of two receiver braces, two removable front bracket arms, and a hardware pack.

Before starting the installation, lay out the kit components in order as they will be used. This will give you a visual idea of how the components work, and will also confirm that everything is present and accounted for.

1. Start by removing the six plastic fasteners across the top of the grille (Fig.C).
2. Then, remove the grille by pulling straight up (Fig.D).
3. Remove the four plastic fasteners across the top of the fascia attaching the fascia to the core support (Fig.E).
4. Remove two 10mm (head) bolts attaching the fascia to the radiator support (Fig.F).

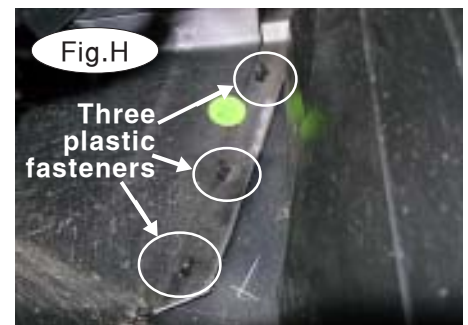

5. Remove three pop rivets on each side of the fender well attaching the fender liner to the fender flair, either by drilling out or by using side cutters (Fig.G).
6. Disconnect the fog lights, if the vehicle is so equipped.
7. There are three plastic fasteners attaching the fender flair to the fascia. They are located on the inside of the fender well. Pinch the plastic tabs together and push out on the fender flair to remove (Fig.H). Repeat for the other side.



# MOUNTING BRACKET KIT INSTALLATION INSTRUCTIONS

**KIT# 1427-3**

09/25/07  
RV

ROADMASTER, Inc. 5602 N.E. Skyport Way Portland, OR 97218 1-800-669-9690 Fax (503) 288-8900 www.roadmasterinc.com



8. Now, on both sides, pull the fender flare slightly out to the side and pull forward on the fascia to remove it (Fig.I).

9. Remove the two frame rail covers to gain access to the inner frame rail by removing one 10mm (head) bolt from each cover (Fig.J)

10. Remove the tow hooks (if the vehicle is so equipped) by removing the three 15mm nuts on each side (Fig.K).

11. Next, on each side, bend the retainer clip (Fig.L) on the tow hook studs and remove the tow hook studs.

12. Working on the passenger side, enlarge the two existing holes located on the bottom of the bumper core with a 1/2" drill bit (Fig.M).

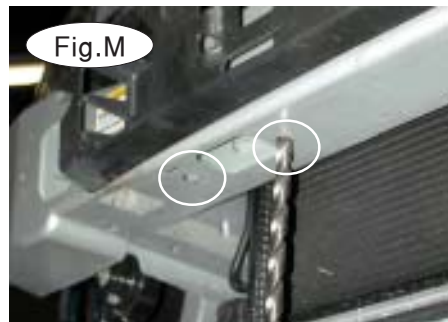

13. Place two 1/2" x 1 1/4" carriage bolts into a 2" x 7" backing plate. *Note:* the holes in the backing plate are offset to match the holes in the bumper core. Now, insert the backing plate into the opening between the two holes you enlarged in step 12 (Fig.N) and thread the bolts through the bumper core (Fig.O).

14. Set the receiver brace in place. Insert the rear portion of the brace between the frame rail and the wiring harness (Fig.P; passenger side only).

15. Attach the front of the receiver brace with two 1/2" lock washers and nuts onto the two 1/2" x 1 1/4" carriage bolts you positioned in step 13 (Fig.Q). Finger tighten only at this time.

16. Repeat steps 10 through 15 to attach the front of the driver's side receiver brace.

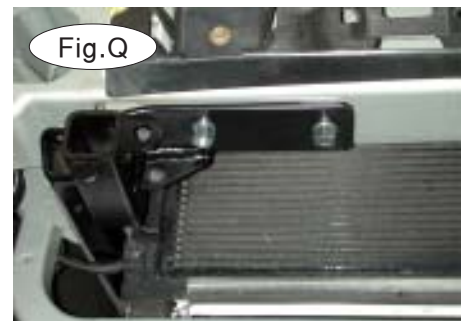
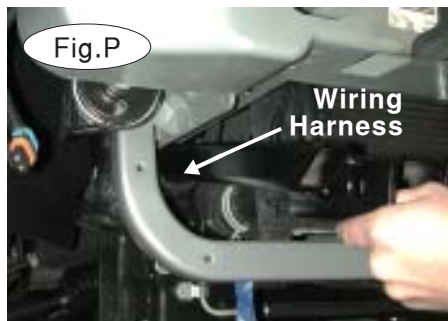





# MOUNTING BRACKET KIT INSTALLATION INSTRUCTIONS

**KIT# 1427-3**

09/25/07  
RV

ROADMASTER, Inc. 5602 N.E. Skyport Way Portland, OR 97218 1-800-669-9690 Fax (503) 288-8900 www.roadmasterinc.com



17. There are three bolts to hold the rear of each receiver brace in place. First, attach the rear bolt – using the attached wire, move the round backing plate with weld nut through the opening in the front of the frame rail and into position (Fig.R). Thread a  $\frac{1}{2}$ " x 3" bolt and  $\frac{1}{2}$ " lock washer through the hole in the round backing plate and the existing hole in the frame rail. Finger-tighten only at this time. Once the bolt is threaded into the backing plate, use pliers to break the wire off the backing plate (Fig.S).

18. To attach the center bolt, use the center hole in the receiver brace and the existing hole in the frame rail as a template. With a  $\frac{1}{2}$ " drill bit, drill through the center reinforcement (Fig.T).

19. Insert a  $1\frac{1}{4}$ " x 2- $\frac{1}{8}$ " pipe spacer over the hole you just drilled, between the bottom of the frame rail and the center reinforcement (Fig.U).

20. Insert a  $\frac{1}{2}$ " x 5" bolt and  $\frac{1}{2}$ " lock washer through the hole you drilled in step 18, through the main brace, the bottom of the frame rail, the pipe spacer, and the center reinforcement.

21. Using the attached wire, position the 2" x 2" backing plate with weld nut on top of the center reinforcement (Fig.V). Thread the  $\frac{1}{2}$ " x 5" bolt through the 2" x 2" backing plate (Fig.W). Finger tighten only at this time. Once the bolt is threaded into the backing plate, use pliers to break the wire off the backing plate.





# MOUNTING BRACKET KIT INSTALLATION INSTRUCTIONS

**KIT# 1427-3**

09/25/07  
RV

ROADMASTER, Inc. 5602 N.E. Skyport Way Portland, OR 97218 1-800-669-9690 Fax (503) 288-8900 www.roadmasterinc.com

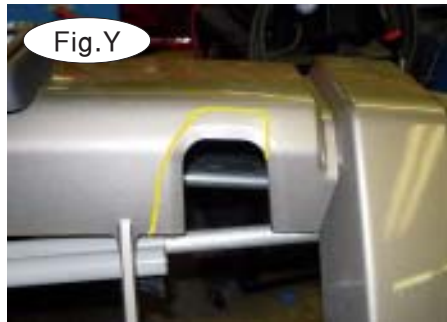

- 22. To attach the third bolt, insert the 1/2" x 1 1/2" bolt through the receiver brace and the bottom of the frame rail (Fig.X). Insert a backing plate, 1/2" lock washer and nut, then finger-tighten only at this time.
- 23. Repeat steps 17 through 22 to attach the rear of the receiver brace to the other side.
- 24. Torque all bolts to the specifications at the end of these instructions. *Note:* to prevent noise vibration, check the center attachment on the rear of both receiver braces to ensure that all slack between the pipe spacers and the center reinforcements is taken up.
- 25. Reattach the two frame rail covers you removed in step 9.
- 26. To accommodate the receiver arms, trim the fascia on both sides. Refer to the yellow marker lines for correct trimming (Fig.Y)
- 26. Reinstall the fascia by reversing steps 1 through 8.

*Note:* the hardware kit includes six new plastic pop rivets to reattach the fascia to the fender liners, three for each side (Fig.Z).

*Note:* for the Jeep Commander, the light plug mounting bracket will have to be bent back approximately 45 degrees to allow for clearance of the fascia).

- 27. Fit the front bracket arms into the front receiver braces, and secure them in place with the supplied 5/8" draw pins and spring pins (Fig.AA)
- 28. Install the tow bar to the mounting bracket according to the manufacturer's instructions. Attach the safety cables to the main receiver brace.



## BOLT TORQUE REQUIREMENTS

Note: The torque values represented below are intended as general guidelines. Torque requirements for specific applications may vary. Roadmaster does not warrant this information to be accurate for all applications and disclaims all liability for any claims or damages which may result from its use.

### STANDARD BOLTS

Thread Size	Grade	Torque
5/16	5	13 ft./lb.
3/8	5	23 ft./lb.
7/16	5	37 ft./lb.
1/2	5	56 ft./lb.
5/8	5	150 ft./lb.

### METRIC BOLTS

Thread Size	Grade	Plated / Unplated
8mm-1.0	8.8	20 ft./lb. 18 ft./lb.
8mm-1.25	8.8	19 ft./lb. 18 ft./lb.
10mm-1.25	8.8	38 ft./lb. 36 ft./lb.
10mm-1.5	8.8	37 ft./lb. 35 ft./lb.

### METRIC BOLTS

Thread Size	Grade	Plated / Unplated
12mm-1.25	8.8	70 ft./lb. 65 ft./lb.
12mm-1.5	8.8	66 ft./lb. 61 ft./lb.
12mm-1.75	8.8	65 ft./lb. 60 ft./lb.
14mm-2.0	8.8	104 ft./lb. 97 ft./lb.

All illustrations and specifications contained herein are based on the latest information available at the time of publication approval. ROADMASTER, INC. reserves the right to make changes at any time without notice in material, specification and models or to discontinue models.