

ecoHITCH - Designed Specifically For Your **Green Vehicle**

Installation Instructions

Application Fits
2011-2014 Subaru Impreza WRX Sedan
X7279 & X7280

DOES NOT FIT HATCHBACK MODEL

2" & 1.25" EcoHitch Invisi

200 lbs. Tongue Weight/2,000 lbs Weight Carrying

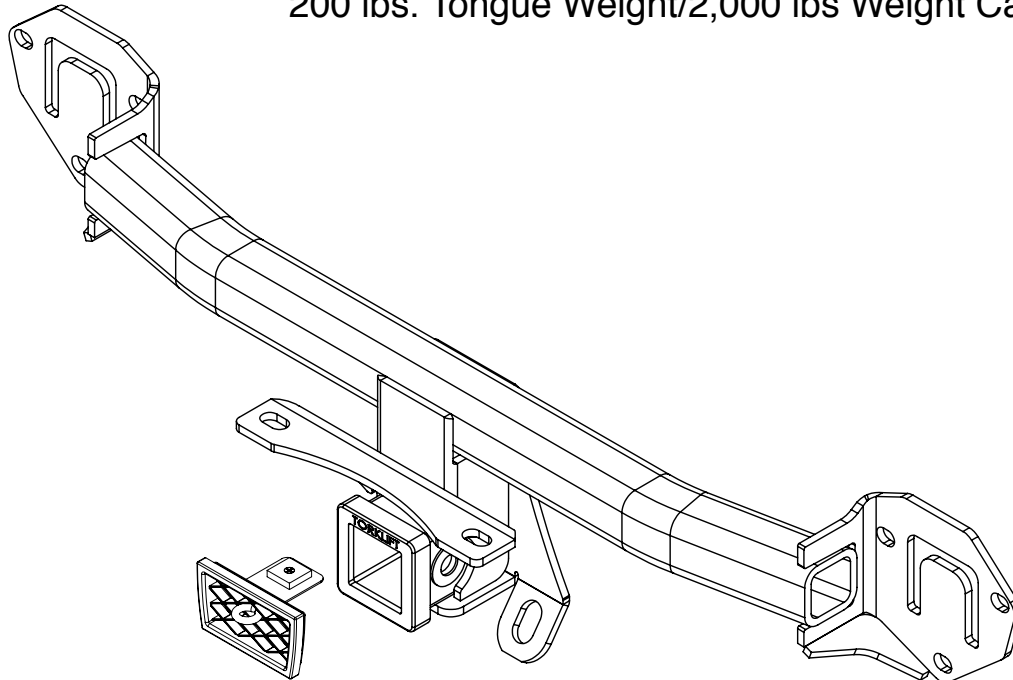

Torklift Central
315 Central Ave N
Kent, WA 98032
253-854-1832
www.torkliftcentral.com
support@tlcentral.com

Stay Connected



torkliftcentral



torkliftcentral



tlcentral



torklift central



torklift central



Bolt Kit Weight: 382g +/-

EcoHitch Hardware

QTY	Fastener
2	3/8" Flat Washer
2	3/8" Lock Washer
2	3/8"-16 Grade 5 Nut
2	3/8"-16 x 5" Grade 5 Hex Bolts
2	1/2" Bevel Washer
6	M10-1.25 Serrated Flange Nut

Hardware Included

Knockout Hardware

QTY	Fastener
1	Magnetic Knockout Plate
4	#6 Flat Washer
2	#6-32 Phillips Head Screws
2	#6-32 Hex Nut
1	1/4"-20 x 1" Eyebolt
1	1/4"-20 Hex Nut
1	1/4"-20 Nylock Nut
1	1/4"-20 Philips Head Screw
1	3/8" Star Lock Washer
1	1"x1"x.25" Magnet

READ THESE INSTRUCTIONS THOROUGHLY AND ACCOUNT FOR ALL HARDWARE LISTED BEFORE BEGINNING INSTALLATION!

Step 1. Open the trunk door and remove the trunk floor mat. Remove the trunk trim panel by removing (3) clips and pulling upwards.

Fig. [1]

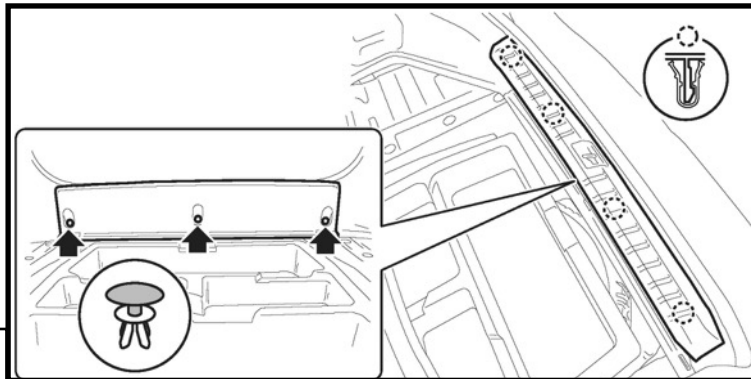

Step 2. Remove the push pin on the rear wall of the trunk compartment noted in Figure [2] and peel back the wall liner. Repeat on opposite side.

Fig. [2]

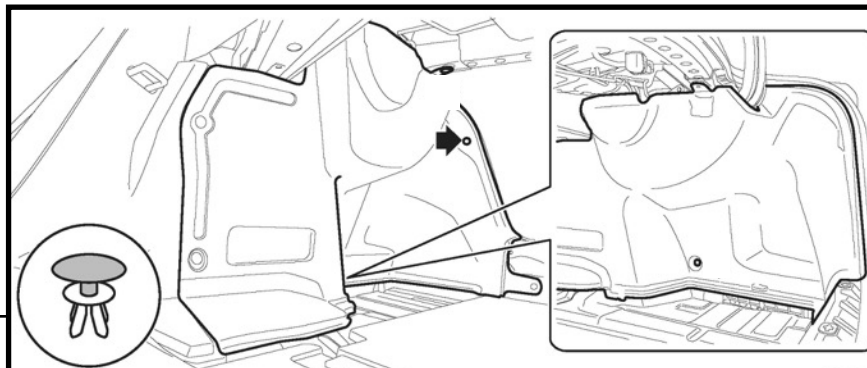

Step 3. Disconnect the wire connector and remove the wire holder from the stud bolt by rotating off. Remove the (4) screws that secure the light assembly to the vehicle and carefully slide the assembly rearward and set aside for reinstallation later. Repeat on opposite side. See Figure [3].

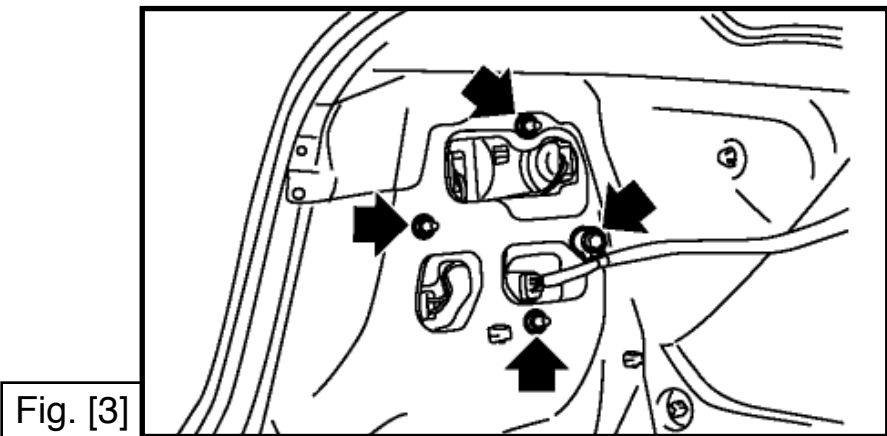

Step 4. Remove the (6) push pin clips on the underside of the bumper fascia as well as (2) center push clips in the top rear of the rear well. Set aside for reinstallation.

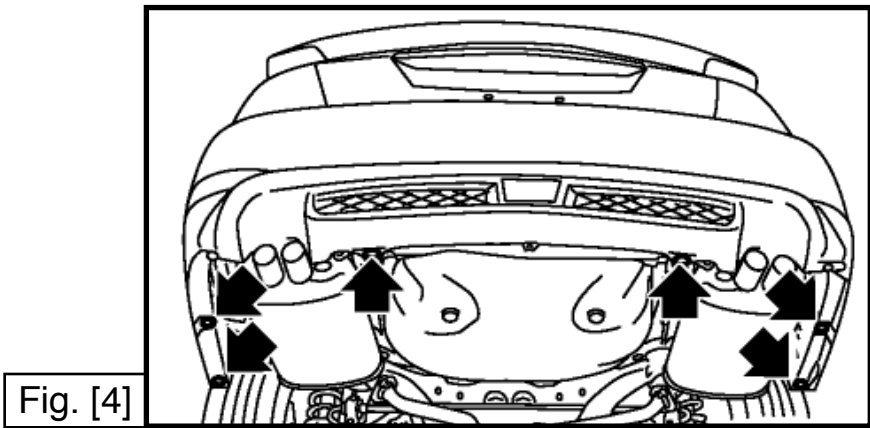

Step 5. Starting at the passenger side, begin gently peeling the bumper fascia from the vehicle. Work your way around towards the rear of the vehicle and then towards the driver side.

NOTE: It may be helpful to have an assistant help hold the bumper fascia during this procedure to avoid dropping the bumper fascia.

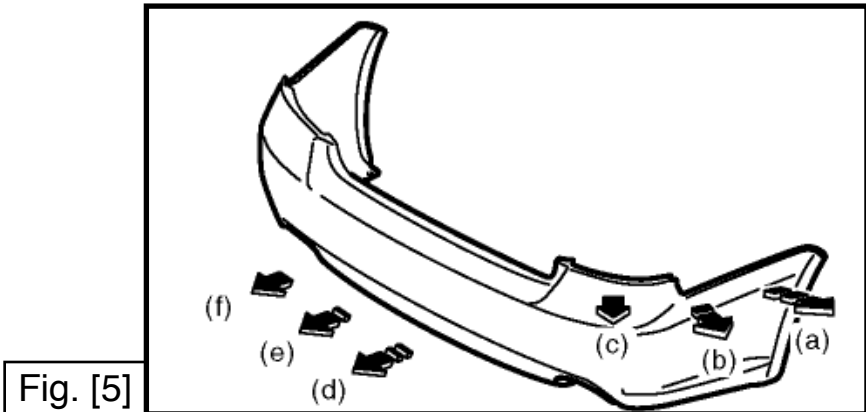

Step 6. Remove the impact bar by removing the (6) nuts. Discard the factory nuts and set impact bar aside.

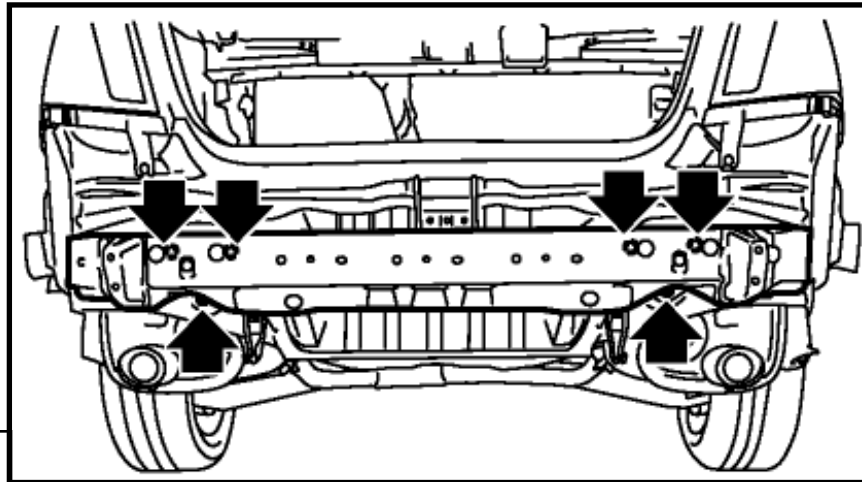

Fig. [6]

Step 7. Place the hitch onto the (6) stud bolts then replace the impact bar and secure with the supplied M10x1.25 serrated flange nuts.

DO NOT TORQUE AT THIS TIME

Step 8. Place (1) 3/8"x5", (1) 3/8" lock washer, and (1) 3/8" bevel washer, through the top of each of the two center holes on the impact bar and through the hitch below. Secure each bolt with (1) 3/8" flat washer and (1) 3/8" hex nut. See Figure [7].

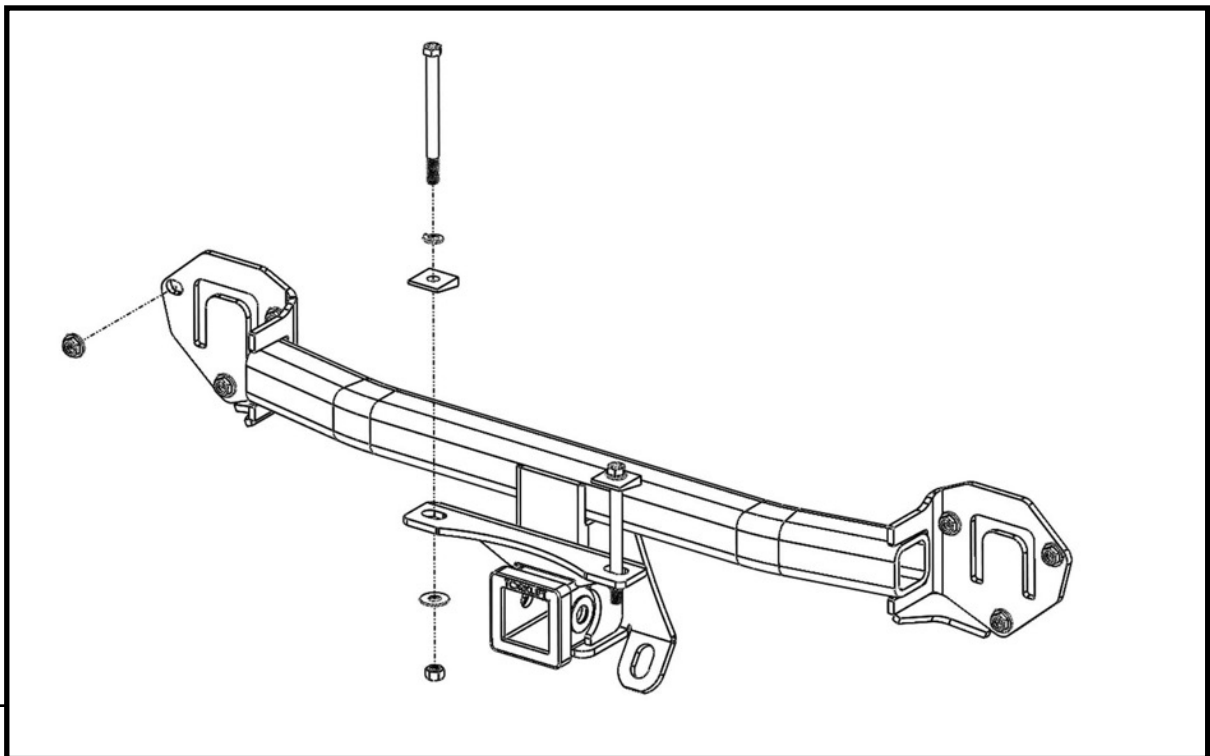

Fig. [7]

Step 9. With all nuts and bolts hand tightened and hitch centered in place, torque all M10 hardware to 31 ft-lbs. Torque all 3/8" hardware to 33 ft-lbs.

Step 10. Remove the lower plastic grille on the bumper fascia by releasing the plastic clips and pushing the grille outward off the bumper fascia. It may be easiest to start at one end of the grille and work your way to the other side. See Figure [8].

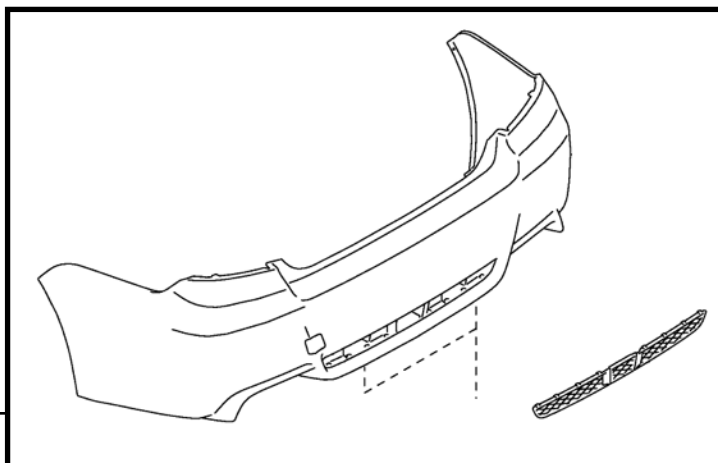

Fig. [8]

Step 11. Mark the plastic grille as shown in Figure [9] & [10] and cut using an air saw or utility knife. Clean any rough edges with a utility knife and set center piece aside.



Fig. [9]



Fig. [10]

Step 12. Mark the center casing of the bumper fascia and use an air saw to remove. **NOTE:** Be sure not to cut the tabs that will hold the knockout in place.

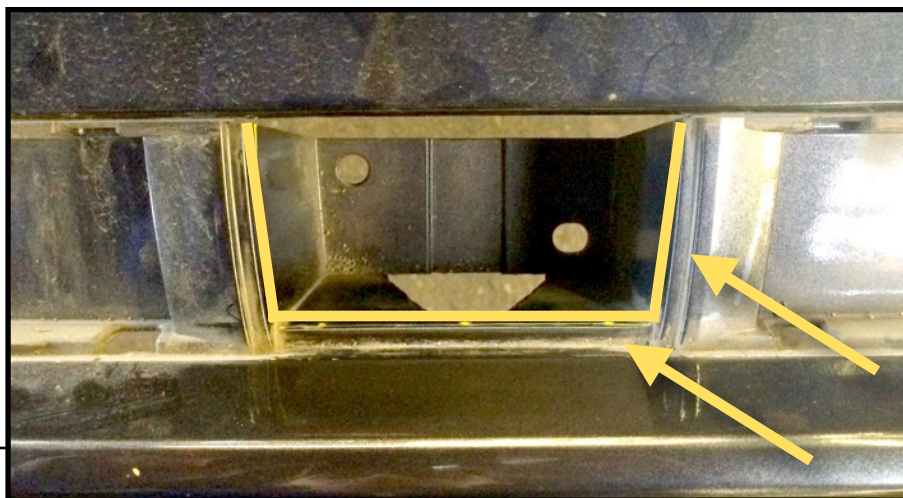

Fig. [11]

DO NOT CUT THESE TABS!

Step 13. Reinstall the two side pieces back into the bumper fascia.

Step 14. Reinstall the bumper fascia and light assemblies by following these steps in reverse starting at Step 5.

Step 15. Using Figure [12], mark and drill (1) 5/16" hole and (2) 3/16" holes on the knockout panel.

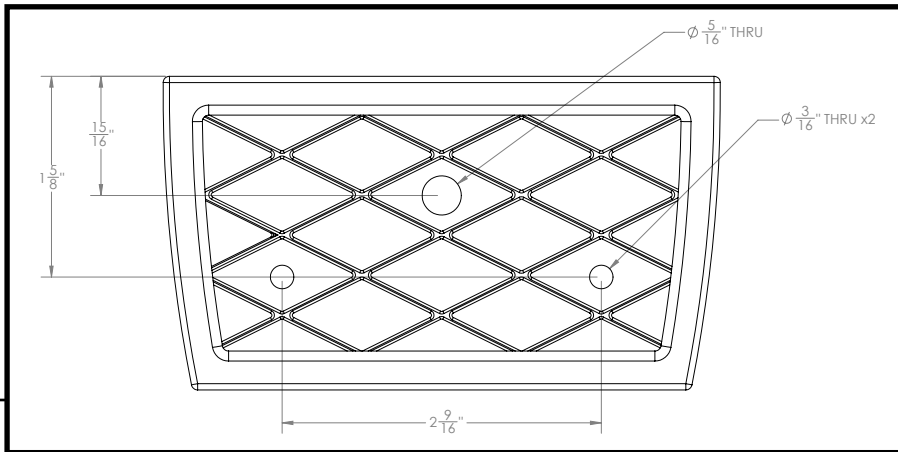

Fig. [12]

Step 16. Attach the modified knockout panel to the Magnetic Knockout Plate (MKP), by placing the 1/4" eye bolt through the 5/16" hole and securing it on the backside of the MKP with (1) 1/4" lock washer and (1) 1/4" nut. Place (1) #6 screw and (1) #6 flat washer through each 3/16" hole and secure on the backside of the MKP with (1) #6 flat washer and (1) #6 nut.

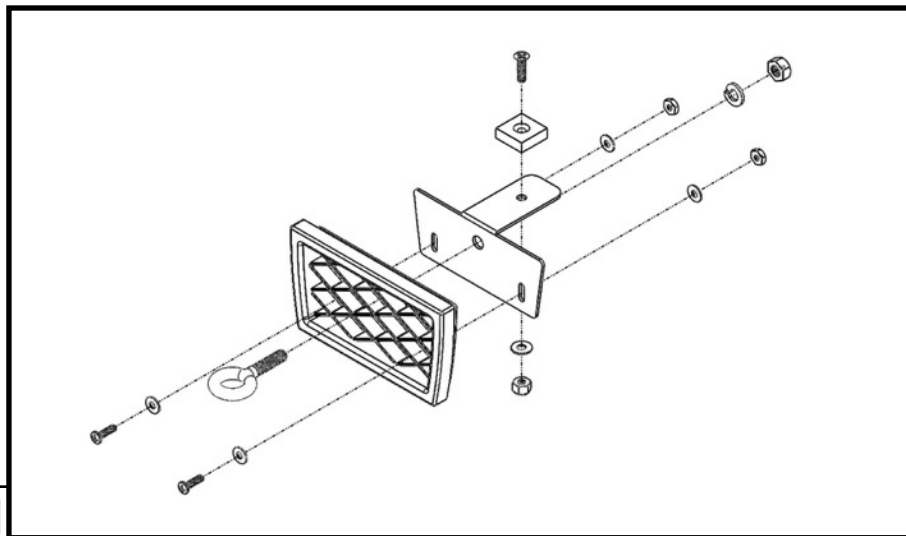

Fig. [13]

Step 17. Slide the newly assembled knockout cover into the hitch receiver.

Congratulations on the completed installation of the Subaru Impreza WRX Invisi Hitch! It is designed with a lifetime warranty for a lifetime of enjoyment. If you have any questions or suggestions please contact our tech support at support@tlcentral.com or by phone at 253 854-1832.

OPTIONAL TRIMMING

It may be easiest to utilize the safety chain loops by doing some optional trimming of the lower bumper fascia. Mark a 10" long square up to the bend in the lower bumper fascia and trim.

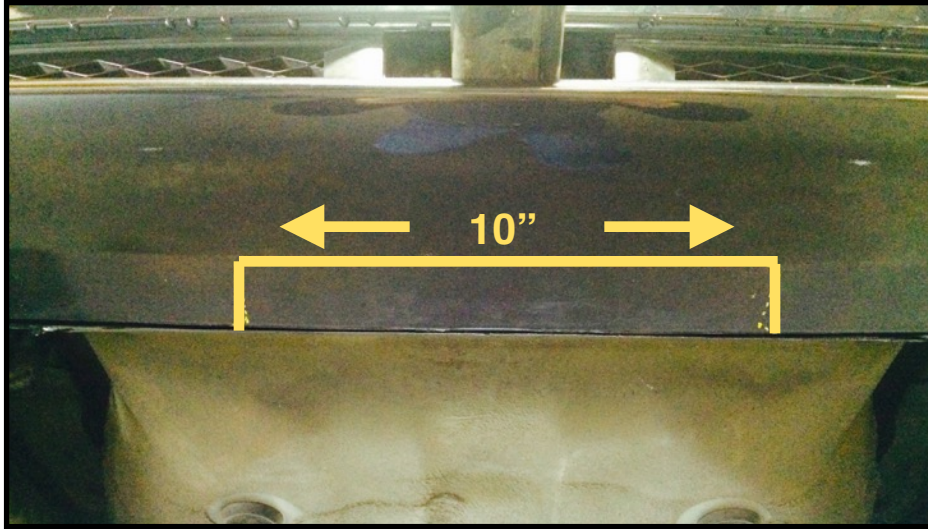

WARRANTY/DISCLAIMER INFORMATION

Torklift Central requires proof of purchase for warranty claim registration, with pictures of any defective product before issuing a replacement. Torklift will not accept claims on any product without proof of purchase, which can be faxed, scanned, emailed or mailed to the information provided below. Torklift Central warrants its hitches, custom hitch receivers and accessories (excluding electrical wire harnesses which carry a warranty from their specified manufacturer) from date of purchase against defects in material and workmanship under normal use and service for the ownership life of the original consumer purchaser. Torklift Central will replace free of charge any part that proves defective in material or workmanship when presented to Torklift Central, transportation charges prepaid by purchaser, at the address below. **This warranty is limited to defective parts replacement only. Labor charges and/or damage incurred in installation or replacement, as well as incidental and consequential damages connected therewith are excluded.** This warranty does not include normal wear and tear or the finish and paint. Rusting, cracking or peeling of the finish is also excluded. Some states do not allow the exclusion or limitation of incidental or consequential damages, so the above limitation or exclusion may not apply to you. Any damage to Torklift Central products as a result of misuse, abuse, neglect, accident, improper installation or any use violative of instructions furnished by Torklift Central will void the warranty. This warranty gives you specific legal rights and you may also have rights, which vary from state to state. With warranty service, you may be able to go to a small claims court, a state court or a federal district court.

Although Torklift Central trailer hitches are both tested and rated for towing within the specific capacity label found on each trailer hitch. Torklift Central assumes no liability for vehicle manufacturers warranty due to the use of a Torklift Central trailer hitch being used for towing behind any vehicle or using the trailer hitch in a manner that it was not designed for. Although this specific trailer hitch has a load rating, which includes trailer tongue weight, and a trailer weight carrying capacity, Torklift Central is not responsible for the voiding of any warranty on any vehicle due to factory towing limitations. All vehicle warranties are the sole property and responsibility of the owner of the vehicle that the Torklift Central trailer hitch is installed upon. Torklift Central does not endorse towing behind any vehicle if the vehicles manufacturer states that towing is not recommended. Check your vehicle's owner's manual for the proper tow rating of your vehicle.

ADDRESS: 315 Central Ave N. Kent, WA 98032

WARNING Your vehicle may have a lower tow rating than this trailer hitch. If your vehicle's tow rating is less than the rated towing capacity on your Torklift Central trailer hitch, your trailer hitch capacity is limited to your vehicle's factory rated towing capacity.

FOR EXAMPLE: the label on your Torklift Central trailer hitch states it's capacity is rated for 500 pounds tongue weight and 5,000 pounds towing weight. However your vehicle's factory rated towing capacity is limited to only 350 pounds tongue weight and 3,500 pounds towing weight. In this example your maximum towing capacity of your Torklift Central trailer hitch is limited to 350 pounds tongue weight and 3,500 pounds towing weight as stated by your vehicle's maximum factory tow rating.

DANGER Never exceed your vehicle's manufacturer's recommended towing capacity which may be a lower rating than this trailer hitch

Unsure of your tow rating? Download our towing app from the app store to find your vehicles tow rating.
www.torkliftcentral.com/app.php