

TORKLIFT INTERNATIONAL

OVER 35 YEARS OF INNOVATION, QUALITY, SAFETY.
IMPORTANT OWNER-OPERATOR INSTALLATION INSTRUCTIONS

D2124

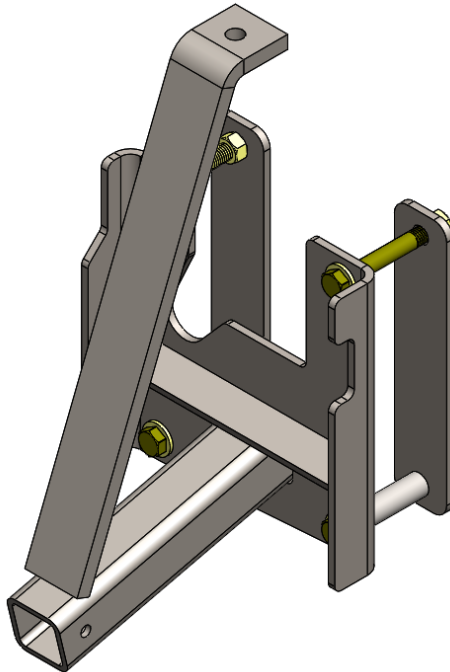

Version 10 BY: JL 8/7/2015

TECH SUPPORT (800) 246-8132

**AFTER INSTALL, PLEASE GIVE
THIS BOOKLET TO YOUR CUSTOMER**

Warnings

Truck Bed and Camper Protection

Torklift **does not** recommend installing your camper on top of a plastic bed liner (or other compressible material such as foam). These materials can act as a spring, causing increased vertical truck camper movement independent of the vehicle. Plastic bed liners can slide on the truck bed surface, and the truck camper can slide on top of the bed liner. Using a plastic bed liner or similar compressible material will void your warranty and may additionally cause truck bed and/or camper damage.







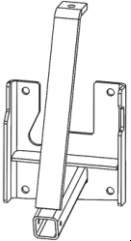
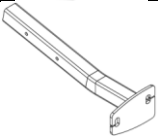

Minor movement or settling can occur in some incidental harsh driving conditions (on or off-road). A rubber bed mat is recommended to protect the truck bed and camper, but is not a requirement to maintain the Torklift legendary lifetime warranty.

Suspension

To significantly reduce body roll, sag and sway Torklift strongly recommends the StableLoad. Torklift International StableLoads improve safety, handling, and to help level your truck. More information can be found at (www.Torklift.com/stableload).

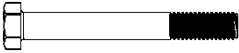
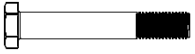
If your truck is additionally equipped with suspension air bags Torklift cautions against over pressurization as this may lead to unsafe vehicle handling characteristics. We have found that airbags used in conjunction with StableLoads have allowed operators to lower air bag pressure by 50% or more. Only pressurize suspension air bags enough to level the truck.

Parts Inventory

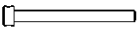
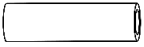
Item Image	Item Description	Quantity
	Tie Down Receivers (Driver side pictured)	2
	Bent Tie Down Inserts	2
	Driver Front Clamp Strap	1
	Passenger Front Clamp Strap	1
	Driver Rear Clamp Straps	1
	Passenger Rear Clamp Strap	1
	1/2"-13 x 4" Grade 8 Hex Bolt	7
	1/2"-13 x 3.5" Grade 8 Hex Bolt	1
	1/2"-13 Grade 8 Hex Nut	7
	1/2" Grade 8 Lock Washer	8
	1/2" SAE Washer	8
	Insert Pin	2
	3/4"OD x 2.6875" Spacer Pipe	4

Step 1:

Begin on the drive side of the vehicle and remove the forward most bed mount bolt as shown below in photo 1.1 below.

Note: The bolt is secured with blue thread locking compound and is tightened to a very high torque value.

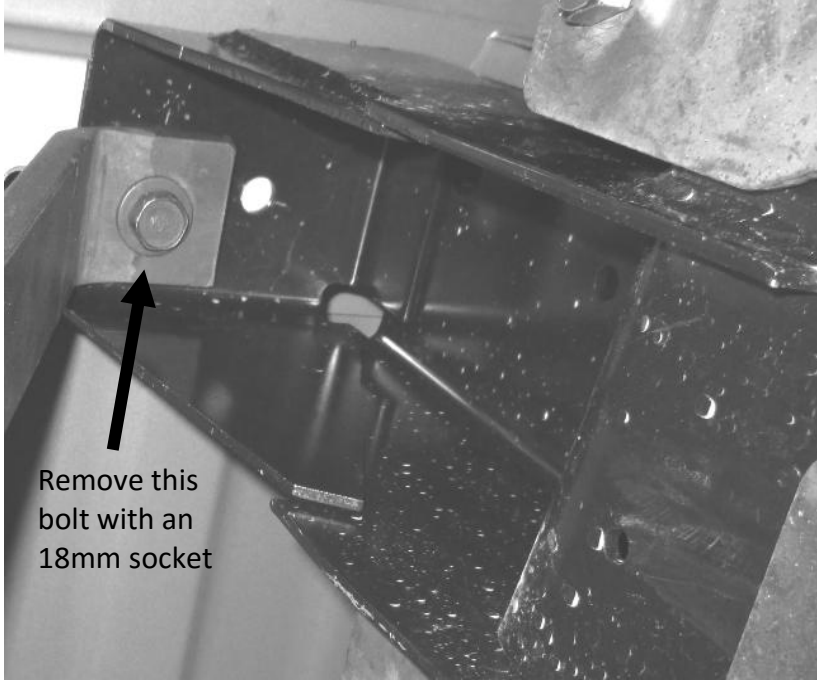

Step 2:

Lift the driver side **tie down receiver** up into place so that the hole in the bent strap aligns with the hole in the vehicle bed mount. Secure the tie down in place by re-installing the bolt removed in step one and leaving finger tight at this time. Reference figure 2.1 on the following page.

Figure 2.1

Driver Side

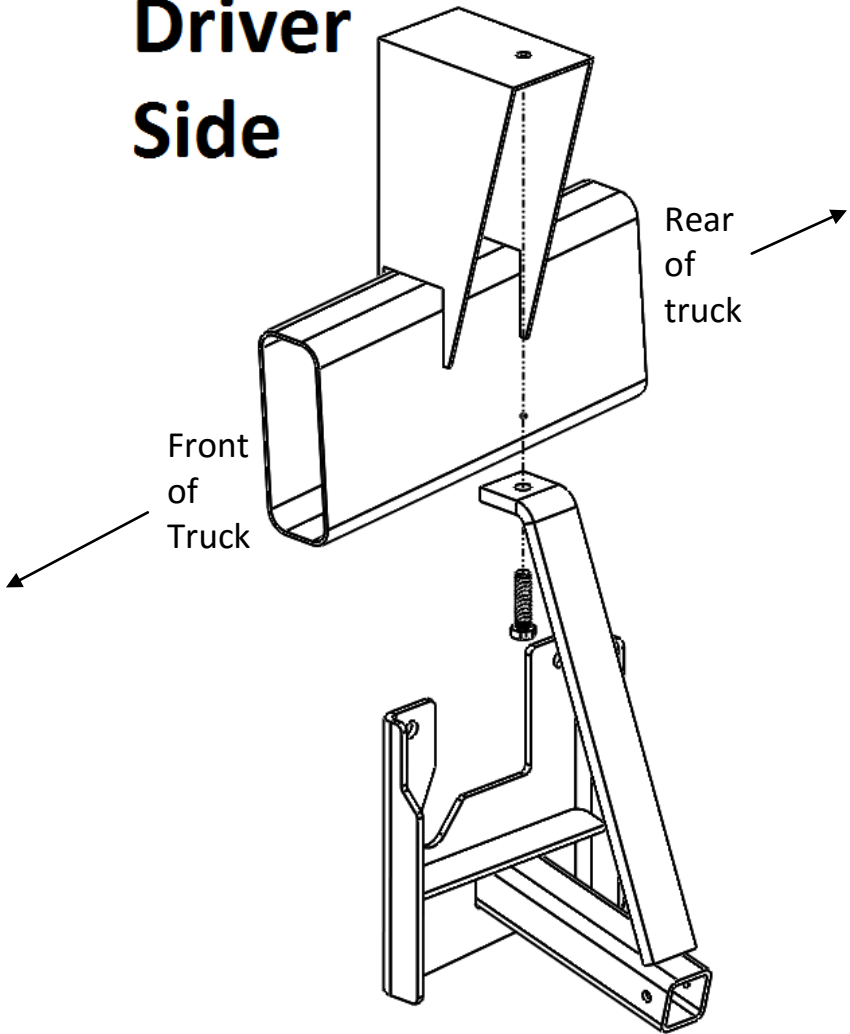

Step 3:

Install the **Driver Front Clamp Strap** on the inside of the frame rail from the top of the frame down. The welded-on nut will be on the top of the frame facing towards the **Tie Down Receiver**. Install the **1/2"-13 x 3.5" Hex Bolt** with one **1/2" Lock Washer** and one **1/2" SAE Washer** through the front of the **tie down receiver** and thread it into the welded on nut of the **Driver Front Clamp Strap**. Reference figure 3.1 and photo 3.2 on the following page.

Figure 3.1

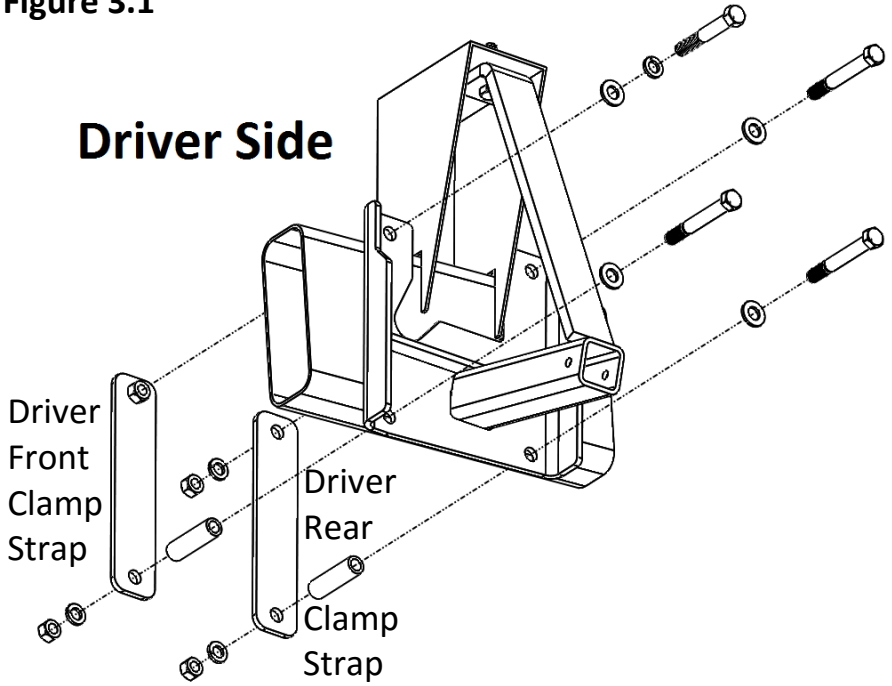

Photo 3.2



Step 4:

Install the **Driver Rear Clamp Strap** on the inside of the frame rail from the bottom of the frame up. Install one **1/2"-13 x 4" Hex Bolt** with one **1/2" SAE Washer** through the front of the **tie down receiver** and out through upper hole in the **Rear Clamp Strap**. Secure with one **1/2" Lock Washer** and one **1/2" Hex Nut**. Reference figure 3.1 and leave hardware hand tight at this time.

Step 5:

Install one **1/2"-13 x 4" Hex Bolt** with one **1/2" SAE Washer** through each of the remaining two holes on the bottom of the **tie down receiver**. Install a spacer pipe onto each bolt between the **tie down receiver** and **clamp straps**. Secure with one **1/2" Lock Washer** and one **1/2" Hex Nut**. Reference figure 3.1 and leave hardware hand tight at this time.

Step 6:

Begin to tighten each of the four hex bolts in turn, until both the front and rear clamp straps are seated flush to the inside of the vehicle frame. Next, re-tighten the bed mount bolt and torque to **80 ft-lbs**. At this time, torque the two upper hex bolts without the tubing spacers to **15 ft-lbs**. Next, torque the lower two hex bolts with the tubing spacers to **55 ft-lbs**.

The driver side tie down installation is complete.

Step 7:

Repeat steps 1 and 2 for the passenger side of the vehicle. Install the **Passenger Front Clamp Strap** on the inside of the frame rail from the bottom of the frame up. The jog in the strap will face the front of the truck to avoid the exhaust hanger stud as shown below. Secure the clamp strap by installing one **1/2"-13 x 4" Hex Bolt** with one **1/2" SAE Washer** through the front of the **tie down receiver** and out through upper hole in the **Passenger Front Clamp Strap**. Secure with one **1/2" Lock Washer** and one **1/2" Hex Nut**. Reference Photo 7.1 and leave hardware hand tight at this time.

**TIEDOWN INSERT INSTALLATION
INSTRUCTIONS**

On one end of each of your tie down inserts is a triangular plate referred to by Torklift as a bullet plate. In most cases, the tie down inserts should be installed with the shorter side of the bullet plate facing away from each other (The shorter side of the front insert should point to the front of the truck and the shorter side of the rear insert should point towards the rear of the truck).



***DRIVERS SIDE FRONT
SIDE REAR***



***DRIVERS
SIDE REAR***

Once installed, attach the TorkLift directional stickers to the face of the bullet plate on the insert as a reminder.

IMPORTANT NOTE: *Your tie down inserts are designed to have clearance inside of the receiver. This is to account for road debris, as well as aid in installation and removal. Some rattle may be expected if the inserts are left installed while not under load from the camper.*

Photo 7.1



Step 8:

Install the **Passenger Rear Clamp Strap** making sure the notch is facing the top of the frame and the front of the truck. Repeat steps 4 through 6 to complete the passenger side tie down installation.

Note: A small plastic plug (pictured in photo 7.1) may need to be removed to install the rear clamp strap on the passenger side.

Step 9:

Install the labeled bent tie down inserts into each receiver. Secure with insert pin.

Torklift International Limited Lifetime Warranty Information

1901 Fryar Ave Sumner, WA 98390

Torklift will require proof of purchase to register, with pictures of any defective product before issuing a replacement. Torklift will not register any product without proof of purchase, which can be faxed, scanned, emailed, or mailed to the information provided below. Torklift warrants its hitches, custom hitch receivers, frame mounted tie downs, turnbuckles, and accessories (excluding wire harnesses which carry a 90 day warranty) from date of purchase against defects in material and workmanship under normal use and service for the ownership life of the original consumer purchaser. All plastic, rubber, and/ or electrical components maintain a warranty of up to one year from the date of the purchase. **ALL COMMERCIAL APPLICATIONS ARE WARRANTED FOR A PERIOD OF 90 DAYS FROM THE DATE OF INSTALLATION/SERVICE.** Torklift will replace **FREE OF CHARGE** any part which proves defective in material or workmanship when presented to Torklift, **TRANSPORTATION CHARGES PREPAID** by purchaser, at the address above. **THIS WARRANTY IS LIMITED TO DEFECTIVE PARTS REPLACEMENT ONLY. LABOR CHARGES AND/OR DAMAGE INCURRED IN INSTALLATION OR REPLACEMENT, AS WELL AS INCIDENTAL AND CONSEQUENTIAL DAMAGES CONNECTED THEREWITH ARE EXCLUDED.** This warranty does not include the finish or paint on our products. Rusting, cracking or peeling of the finish is also excluded. Some states do not allow the exclusion or limitation of incidental or consequential damages, so the above limitation or exclusion may not apply to you. Any damage to Torklift products as a result of misuse, abuse, neglect, accident, improper installation or any use violative of instructions furnished by Torklift or **WHEN USED IN ANY COMMERCIAL APPLICATION WILL VOID THE WARRANTY.** This warranty gives you specific legal rights, and you may also have rights which vary from state to state. With warranty service, you may be able to go to a small claims court, a state court or a federal district court.



TORKLIFT™

INTERNATIONAL

322 Railroad Ave North, Kent, WA 98032

Phone (800) 246-8132

Fax (253) 854-8003

Or visit our website: www.TorkLift.com

Dear Valued Customer,

Thank you for making TorkLift your choice for truck, camper packages and accessories for your vehicle. By choosing TorkLift products, you have chosen a company that has been serving the RV industry for nearly 40 years and whose name has become synonymous with strength, quality and advanced design and installation.

Please take a few moments of your time to complete the Product Registration Warranty Card on the next page. When registering your newly purchased TorkLift products, you can be assured that your contact information is secure and that you and your product are getting the attention and respect that you deserve.

Thank you again for choosing TorkLift quality products.

Register for your lifetime warranty and receive a free Torklift International gift.

To Fax: Send copies of the questionnaire, warranty card and receipt to
253-854-8003

To E-mail: Send copies of the questionnaire, warranty card and receipt to
warranty@torklift.com

To Mail: Send to Torklift International 322 Railroad Ave North, Kent, WA
98032



OFFICIAL WARRANTY REGISTRATION CARD

PLEASE FILL OUT THIS FORM COMPLETELY AND RETURN TO TORKLIFT WITHIN

30 DAYS OF PURCHASE ACCOMPANIED BY A COPY OF YOUR ORIGINAL RECEIPT

1. PART(S) PURCHASED

TODAY'S DATE: _____

PART #: _____ PART #: _____

PART #: _____ PART #: _____

PART #: _____ PART #: _____

2. PURCHASER INFORMATION

NAME: _____

ADDRESS: _____

CITY: _____ STATE: _____ ZIP / POSTAL CODE: _____

PHONE: (____) _____ - _____ EMAIL: _____

3. TRUCK INFORMATION

YEAR: _____ MAKE: _____

MODEL: _____ BED LENGTH: _____

4. CAMPER INFORMATION

YEAR: _____ MAKE: _____ MODEL: _____

5. DEALER INFORMATION

PURCHASED FROM: _____

ADDRESS: _____

CITY: _____ STATE: _____ ZIP / POSTAL: _____

INSTALLED BY: _____ OWNER ABOVE DEALER ANOTHER DEALER

IF ANOTHER DEALER, WHO: _____