

# **TORKLIFT** **INTERNATIONAL**

**OVER 35 YEARS OF INNOVATION, QUALITY, SAFETY.**

## **TRUE FRAME MOUNTED CAMPER TIE DOWNS**

**IMPORTANT OWNER-OPERATOR INSTALLATION INSTRUCTIONS**

**Part # C2214A**

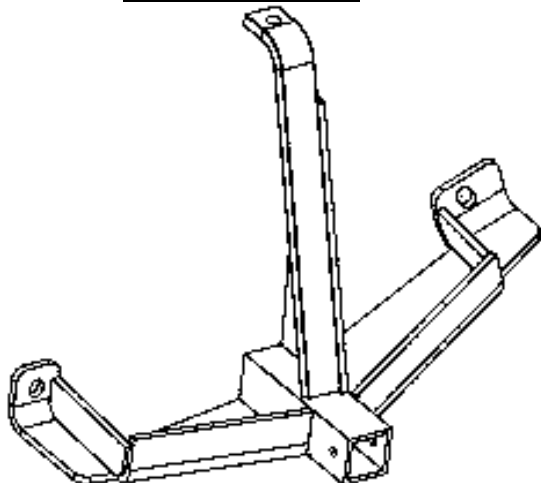

REVISED version 9 BY: JL 8-05-2015  
**TECH SUPPORT (800) 246-8132**

**AFTER INSTALL, PLEASE GIVE  
THIS BOOKLET TO YOUR CUSTOMER**

# Warnings

## Truck Bed and Camper Protection









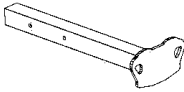

Torklift **does not** recommend installing your camper on top of a plastic bed liner (or other compressible material such as foam). These materials can act as a spring, causing increased vertical truck camper movement independent of the vehicle. Plastic bed liners can slide on the truck bed surface, and the truck camper can slide on top of the bed liner. Using a plastic bed liner or similar compressible material will void your warranty and may additionally cause truck bed and/or camper damage.

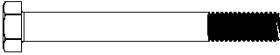
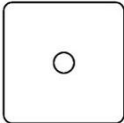
Minor movement or settling can occur in some incidental harsh driving conditions (on or off-road). A rubber bed mat is recommended to protect the truck bed and camper, but is not a requirement to maintain the Torklift legendary lifetime warranty.

## Suspension

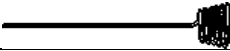
To significantly reduce body roll, sag and sway Torklift strongly recommends the StableLoad. Torklift International StableLoads improve safety, handling, and to help level your truck. More information can be found at ([www.Torklift.com/stableload](http://www.Torklift.com/stableload)).

If your truck is additionally equipped with suspension air bags Torklift cautions against over pressurization as this may lead to unsafe vehicle handling characteristics. We have found that airbags used in conjunction with StableLoads have allowed operators to lower air bag pressure by 50% or more. Only pressurize suspension air bags enough to level the truck.

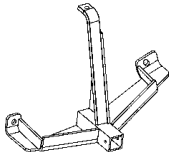
	Straight Tie-Down Insert	2
	7/16" x 2" Grade 8 Bolt	2
	1/2" x 5" Grade 5 Bolt	2
	3.5"(8.89cm) Sq Washer	2
	1"(2.54cm) x 2"(5.08cm) Plate Washer	2
	1/2" SAE Flat Washer	2
	7/16" USS Flat Washer	2
	1/2" Bolt Fisher	1
	1/2"-13 Serrated Grade 5 Nut	2
	7/16"-14 Grade 8 Nut	2
	1/2" Star Washer	2
	7/16" Lock Washer	2
	TD Finishing Kit	1
	Tie-Down	2

**INSTALLATION INSTRUCTIONS: READ AND UNDERSTAND ALL INSTRUCTIONS BEFORE STARTING:**

**STEP 1**

**DRIVERS SIDE FIRST:** Locate and remove the forward most bolt attaching the bed to the truck frame.

**STEP 2**

Attach the supplied **1/2" bolt fisher** to the **7/16" x 2" Grade 8 Bolt**. Place the bolt into the slotted hole on the angled portion of the frame rearward of the bed mount. With the bolt inside of the frame, slide a **1/2" Star Washer** and **1"(2.54cm) x 2"(5.08cm) Plate Washer** onto the wire end of the **1/2" Bolt Fisher**, and slide them into the frame. (See figure 2.1) Leave the wire end of the **1/2" Bolt Fisher** outside of the frame.

**Figure 2.1**

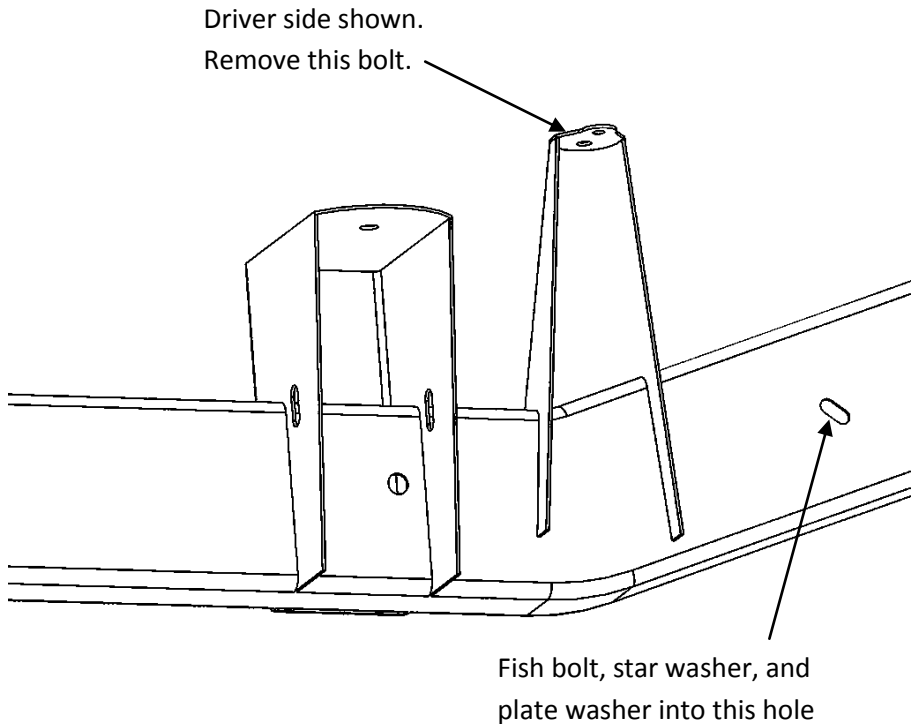

### STEP 3

With the hardware in the frame, run the wire end of the **1/2" Bolt Fisher** through the slotted hole in the **Tie-Down**. Using the factory bolt removed in **Step 1**, bolt the upper hole of the **Tie-Down** into forward most bed mount. Leave loose at this time.

### STEP 4

Using the **1/2" Bolt Fisher**, pull the **7/16" x 2" Grade 8 Bolt** back through the **1/2" Star Washer**, **1" (2.54cm) x 2" (5.08cm) Plate Washer**, Truck Frame, and Tie-Down. Carefully hold the end of the bolt while disconnecting the bolt fisher from the **7/16" x 2" Grade 8 Bolt**. Loosely install a **7/16" USS Flat Washer**, **7/16" Lock Washer**, and a **7/16"-14 grade 8 nut**. Be careful not to drop the bolt back into the frame without the bolt fisher attached.

### STEP 5

Install a **1/2" x 5" Grade 5 Bolt** and **1/2" SAE Flat Washer** through the round hole in the Tie-Down and through the frame. Secure the threaded side of the bolt with a **3.5" (8.89cm) Sq Washer** and **1/2"-13 Serrated Grade 5 Nut**. (See Figure 5.1)

**Figure 5.1**

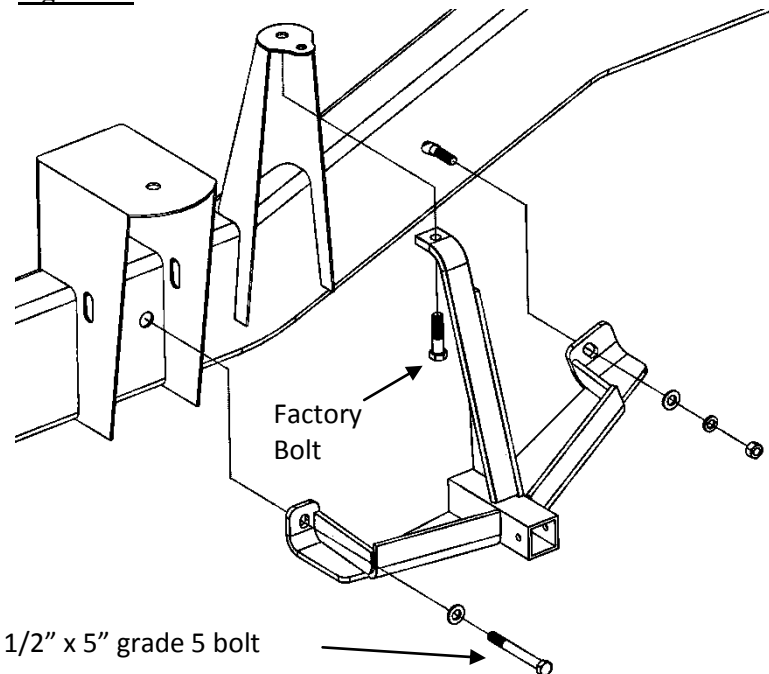

## STEP 6

Torque the 7/16" x 2" Grade 8 Bolt and the factory bed mounting bolt to **50 ft-lbs.(67nm)**

Torque the 1/2" x 5" Grade 5 Bolt to **30 ft-lbs.(40nm)**

## STEP 7

Install the driver side **Straight Tie-Down Insert** into the **Tie-Down** receiver tube. Secure the **Straight Tie-Down Insert** with the included **Tie Down Lock**. Either of the holes in the insert can be used as long as there is enough clearance between the turnbuckles and the body of the truck.

## STEP 8

Repeat steps 1-7 on the passenger side of the truck.

**TD FINISHING KIT:** Generic **Aluminum Tie Down** picture is used for illustration purposes. **Aluminum Tie Down** design may vary.

### **TD Finishing Kit**

	1-3/4" x 1-3/4" X 2" Foam Backing Plug	2
	2" x 2" x 1-1/2" Receiver Cap	2

### **Step 1**

Insert one **1-3/4" x 1-3/4" x 2" Foam Backing Plug** into the back of the **Aluminum Tie Down Receiver** opening. If the back of the receiver is inaccessible, insert the Foam Backing Plug in the front of the **Aluminum Tie Down Receiver** and press it back with the **Tie Down Insert**. See Photo 1.1

**Photo 1.1**

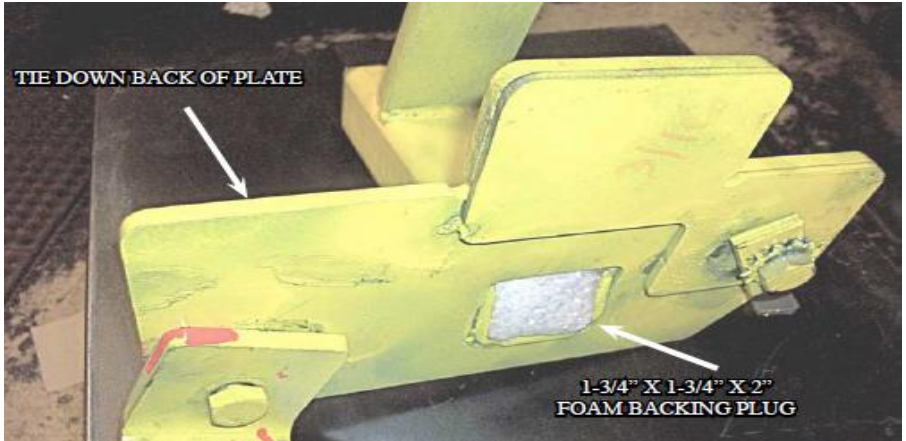

**Step 2**

Insert one **2" x 2" x 1-1/2" Receiver Cap** over the end of the **Aluminum Tie Down Receiver**. See Photo 2.1 (if the 2" x 2" x 1-1/2" Receiver Cap does not fit over the receiver, you will need to notch it out using a box knife or similar) See Photo 2.2.

**Photo 2.2**



## **TIEDOWN INSERT INSTALLATION INSTRUCTIONS**

*On one end of each of your tie down inserts is a triangular plate referred to by Torklift as a bullet plate. In most cases, the tie down inserts should be installed with the shorter side of the bullet plate facing away from each other, i.e.. The shorter side of the front insert should point to the front of the truck and the shorter side of the rear insert should point towards the rear of the truck.*



### ***DRIVERS SIDE FRONT***

### ***DRIVERS SIDE REAR***

*Once installed, attach the TorkLift directional stickers to the face of the bullet plate on the insert as a reminder.*

***IMPORTANT NOTE:*** *Your tie down inserts are designed to have clearance inside of the receiver. This is to account for road debris, as well as aid in installation and removal. Some rattle may be expected if the inserts are left installed while not under load from the camper.*



# **Torklift International Limited Lifetime Warranty Information**

**322 Railroad Ave North, Kent, WA 98032**

Torklift will require proof of purchase to register, with pictures of any defective product before issuing a replacement. Torklift will not register any product without proof of purchase, which can be faxed, scanned, emailed, or mailed to the information provided below. Torklift warrants its hitches, custom hitch receivers, frame mounted tie downs, turnbuckles, and accessories (excluding wire harnesses which carry a 90 day warranty) from date of purchase against defects in material and workmanship under normal use and service for the ownership life of the original consumer purchaser. All plastic, rubber, and/ or electrical components maintain a warranty of up to one year from the date of the purchase. **ALL COMMERCIAL APPLICATIONS ARE WARRANTED FOR A PERIOD OF 90 DAYS FROM THE DATE OF INSTALLATION/SERVICE.** Torklift will replace **FREE OF CHARGE** any part which proves defective in material or workmanship when presented to Torklift, **TRANSPORTATION CHARGES PREPAID** by purchaser, at the address above. **THIS WARRANTY IS LIMITED TO DEFECTIVE PARTS REPLACEMENT ONLY. LABOR CHARGES AND/OR DAMAGE INCURRED IN INSTALLATION OR REPLACEMENT, AS WELL AS INCIDENTAL AND CONSEQUENTIAL DAMAGES CONNECTED THEREWITH ARE EXCLUDED.** This warranty does not include the finish or paint on our products. Rusting, cracking or peeling of the finish is also excluded. Some states do not allow the exclusion or limitation of incidental or consequential damages, so the above limitation or exclusion may not apply to you. Any damage to Torklift products as a result of misuse, abuse, neglect, accident, improper installation or any use violative of instructions furnished by Torklift or **WHEN USED IN ANY COMMERCIAL APPLICATION WILL VOID THE WARRANTY.** This warranty gives you specific legal rights, and you may also have rights which vary from state to state. With warranty service, you may be able to go to a small claims court, a state court or a federal district court.

**322 Railroad Ave North, Kent, WA 98032**  
**Phone (800) 246-8132 Fax (253) 854-8003**  
**Or visit our website: [www.TorkLift.com](http://www.TorkLift.com)**

Dear Valued Customer,

Thank you for making TorkLift your choice for truck, camper packages and accessories for your vehicle. By choosing TorkLift products, you have chosen a company that has been serving the RV industry for nearly 40 years and whose name has become synonymous with strength, quality and advanced design and installation.

Please take a few moments of your time to complete the Product Registration Warranty Card on the next page. When registering your newly purchased TorkLift products, you can be assured that your contact information is secure and that you and your product are getting the attention and respect that you deserve.

Thank you again for choosing TorkLift quality products.

**Register for your lifetime warranty and receive a free Torklift International gift.**

To Fax: Send copies of the questionnaire, warranty card and receipt to  
253-854-8003

To E-mail: Send copies of the questionnaire, warranty card and receipt to  
[warranty@torklift.com](mailto:warranty@torklift.com)

To Mail: Send to Torklift International **322 Railroad Ave North, Kent,  
WA 98032**

**OFFICIAL WARRANTY REGISTRATION CARD**

PLEASE FILL OUT THIS FORM COMPLETELY AND RETURN TO TORKLIFT WITHIN



30 DAYS OF PURCHASE ACCOMPANIED BY A COPY OF YOUR ORIGINAL RECEIPT

**1. PART(S) PURCHASED**

TODAY'S DATE: \_\_\_\_\_

PART #: \_\_\_\_\_ PART #: \_\_\_\_\_

PART #: \_\_\_\_\_ PART #: \_\_\_\_\_

PART #: \_\_\_\_\_ PART #: \_\_\_\_\_

**2. PURCHASER INFORMATION**

NAME: \_\_\_\_\_

ADDRESS: \_\_\_\_\_

CITY: \_\_\_\_\_ STATE: \_\_\_\_\_ ZIP / POSTAL CODE: \_\_\_\_\_

PHONE: (\_\_\_\_) \_\_\_\_\_ - \_\_\_\_\_ EMAIL: \_\_\_\_\_

**3. TRUCK INFORMATION**

YEAR: \_\_\_\_\_ MAKE: \_\_\_\_\_

MODEL: \_\_\_\_\_ BED LENGTH: \_\_\_\_\_

**4. CAMPER INFORMATION**

YEAR: \_\_\_\_\_ MAKE: \_\_\_\_\_ MODEL: \_\_\_\_\_

**5. DEALER INFORMATION**

PURCHASED FROM: \_\_\_\_\_

ADDRESS: \_\_\_\_\_

CITY: \_\_\_\_\_ STATE: \_\_\_\_\_ ZIP / POSTAL: \_\_\_\_\_

INSTALLED BY: \_\_\_\_\_ OWNER ABOVE DEALER ANOTHER DEALER

IF ANOTHER DEALER, WHO: \_\_\_\_\_