



**- SUPER HITCH -  
SUPER TRUSS EXTENSION**

**IMPORTANT OWNER-OPERATOR INSTALLATION INSTRUCTIONS**

**C1204/SH01CHSB**

**APPLICATION FITS**

**CHEVY 2500/3500 HD  
2001-2006 SHORT BED**

**PLEASE GIVE THIS BOOKLET TO YOUR CUSTOMER  
AS IT CONTAINS CRITICAL OPERATOR INFORMATION**

**REV HHB 6-26-06  
TECH SUPPORT (800) 246-8132**



**C1204 PARTS INVENTORY**

- 2 - frame side plates
- 1 - double receiver crosstube
- 8 - 1/2" x 1 1/2" rib neck bolts
- 2 - M14 X 2.0 X 40MM 8.8 bolts
- 2 - 9/16" flat washers
- 2 - 9/16" lock washers
- 8 - 1/2" X 2" Grd 8 hex bolts
- 18 - 1/2" X 13 Grd 8 nut
- 8 - 1" X 2" plate washers
- 18 - 1/2" lock washers
- 20 - 1/2" flat washers
- 2 - 5-8" pins
- 1 - plug bracket
- 1 - bolt
- 1 - nut
- 1 - washer

**WARNING:** DO NOT LUBRICATE THREADS. BOLT FAILURE MAY OCCUR DUE TO OVERTIGHTENING. DO NOT DRILL ON THIS HITCH. **NOTE:** THIS PRODUCT IS NOT RECOMMENDED FOR USE ON A 1/2 TON VEHICLE.

**NOTE THE DIRECTION OF THE SUPERHITCH SIDE PLATES BEFORE ASSEMBLY**

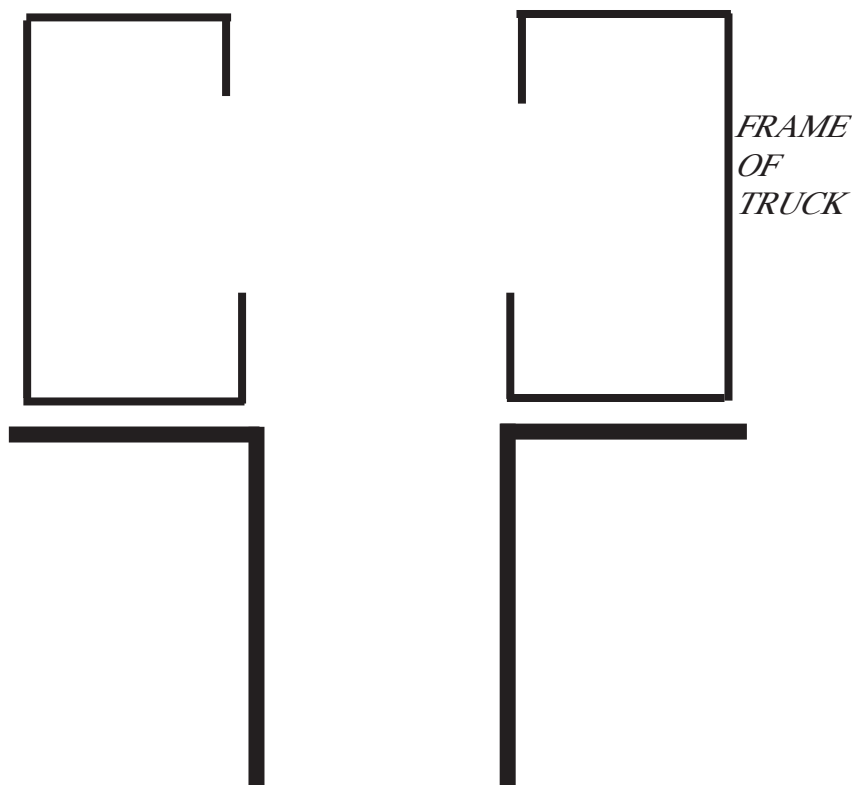

**SUPERHITCH PLATES RUN-IN TOWARDS THE CENTER OF THE TRUCK FRAME IN THIS APPLICATION**

## **INSTALLATION INSTRUCTIONS**

1A. Installation Option A - 1 Person: Attach SuperHitch frame side plates to the frame as instructed in steps 4 & 5. Install the double receiver crosstube using the 8 - 1/2" x 1 1/2" rib neck stud bolts with the threads in toward the spare tire and tightening on the opposite side with 8 - 1/2" lock washers and 8 - 1/2" x 13 nuts. Tighten to 75 ft. lbs. Note: When installing the rib neck stud bolts use a mallet or hammer and a block of wood to seat the bolt heads against the frame side plates. Do not! Use power tools or hand tools to "draw" the rib neck stud bolts through the holes. To simplify seating the stud bolts, use vise grips to clamp the SuperHitch crosstube to the side frame plate and snug the bolts in the frame. This will minimize movement and ease this process. You may now continue on to step 6.

1B. Installation Option B - 2 People: Assemble frame side plates and double receiver crosstube together using the 8 - 1/2" x 1 1/2" rib neck bolts (make sure the threads on the bolts face toward the crosstube) and on the opposite side tightening with 8 - 1/2" lock washers and 8 - 1/2" x 13 nuts. Tighten to 75ft lbs. Note: When installing the 1/2" X 1 1/2" rib neck bolts, use a mallet or a hammer and a block of wood to seat the bolt heads against the frame side plates. **DO NOT** use power or hand tools to "draw" the Rib-Neck bolts through the hole. After this step, the assembled frame side plates and double receiver crosstube will be referred to as the SuperHitch.

2. Position the SuperHitch under rear of the truck using a floor jack or two people.
3. Loosen spare tire so it can be pushed forward if necessary.
4. Hold or jack hitch into position, lining the two rear holes in the frame that have factory bolts and nut plates on them up with the two rear holes closest to the bumper of the SuperHitch. On trucks without the factory receiver hitch, install the two supplied 14mm x 40mm bolts in these holes, using this bolt with 9/16" flat washer and lock washer (on trucks with the factory receiver hitch reuse factory bolts). Finger tighten these bolts.
5. Now drop in the remaining bolts with 1" X 2" plate washer under the head of the bolt (threads pointing towards the ground). From the bottom, install two 1/2" flat washers, one lock washer and one 1/2" nut on each of these bolts and tighten to 100 ft lbs. 5 bolts minimum per side.
6. Retighten spare tire and install SuperTruss extension (sold seperately).
7. Torque all Grd 8 1/2" nuts to 100 ft lbs.
8. Some vehicles may require tailpipe modification.

**IMPORTANT NOTE:** USE ONLY SUPPLIED OR APPROVED BOLTS, LOCK WASHERS AND NUTS TO INSTALL THIS HITCH. \* This trailer hitch must have a minimum of 5 bolts per side (ten bolts total) and be installed per these specifications or your warranty is void.

# **SUPERHITCH INSTALLATION PHOTOS**

**Note: Pictures 1 and 2 show the SUPERHITCH if you decide to install the parts to the vehicle before preassembling the Side Plates and Double Receiver Crosstube**



**THIS PHOTO SHOWS THE SUPERHITCH SIDE BRACKETS INSTALLED**



**HERE IS A REAR DRIVER SIDE VIEW OF THE FULLY ASSEMBLED SUPERHITCH**



**THIS IS A PASSENGER SIDE VIEW OF THE FULLY ASSEMBLED SUPERHITCH**



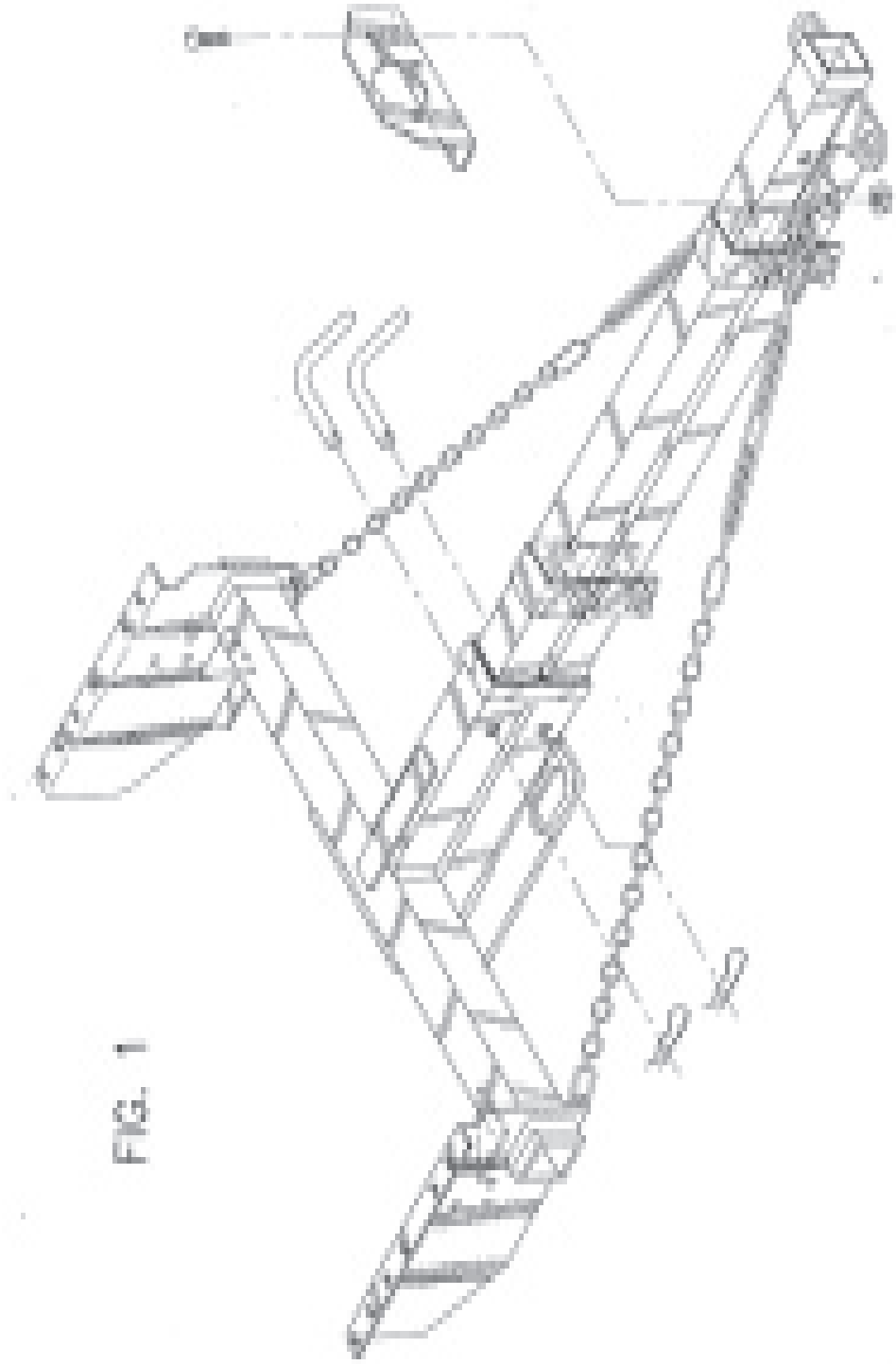

FIG. 1

# **SUPERHITCH DIAGRAM**

# SUPERTRUSS EXTENSION

## WEIGHT CAPACITIES

(SUPERTRUSS SOLD SEPARATELY)

ASSEMBLE THE CHAIN, BOW SHACKLES AND TURNBUCKLES AS SHOWN. TIGHTEN BOW SHACKLES AND TURNBUCKLE JAM NUTS WITH HAND TOOLS (TIGHTEN TURNBUCKLES BY HAND - DO NOT USE TOOLS TO TENSION TURNBUCKLES)

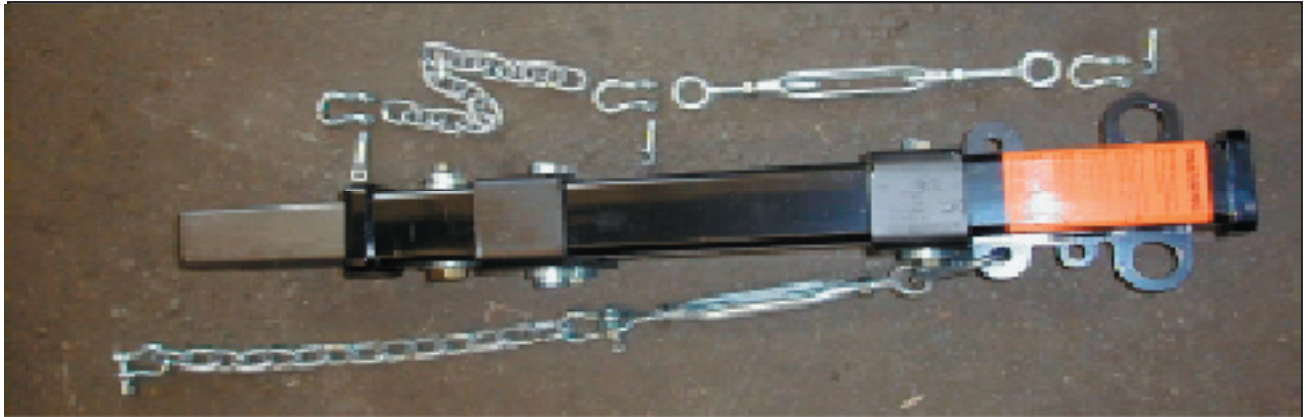

## WARNING - READ CAREFULLY

<u>Dead Weight (weight carrying)</u>		<u>Weight Distributing (load equalizing)</u>		
<u>Tongue Weight</u>	<u>Pull Weight</u>	<u>Tongue Weight</u>	<u>Pull Weight</u>	
48"	600 lb.	6,000 lb.	1,200 lb.	12,000 lb.
42"	600 lb.	6,000 lb.	1,200 lb.	12,000 lb.
36"	650 lb.	6,500 lb.	1,200 lb.	12,000 lb.
32"	650 lb.	6,500 lb.	1,200 lb.	12,000 lb.
28"	750 lb.	7,500 lb.	1,200 lb.	12,000 lb.
24"	750 lb.	7,500 lb.	1,400 lb.	14,000 lb.
21"	750 lb.	7,500 lb.	1,400 lb.	14,000 lb.

**THE USE OF THIS PRODUCT WITHOUT A LOAD EQUALIZING SYSTEM LIMITS YOUR CAPACITY TO THE DEAD WEIGHT (WEIGHT CARRYING) CAPACITY. FAILURE TO STAY WITHIN THESE LIMITATIONS WILL RESULT IN DAMAGE AND VOID YOUR WARRANTY!!!!**

The TorkLift SuperTruss Extension cannot be used with any other type of trailer hitch receiver. Any attempt to modify or recreate a SuperHitch receiver will result in a loss of warranty. The modification of another factory or aftermarket trailer hitch receiver in an attempt to use a TorkLift SuperTruss extension can result in death or damage. The SuperHitch receiver made by TorkLift is a special extra heavy-duty trailer hitch receiver, and the capacities stated for the SuperTruss extension are solely with the use of a TorkLift SuperHitch. Please call if you have any questions on installs or otherwise at 1-800-246-8132.

**THESE STEPS MAY VARY DEPENDING  
ON WEIGHT DISTRIBUTION HITCH  
MANUFACTURER  
WEIGHT DISTRIBUTING  
(LOAD EQUALIZING HITCH)**

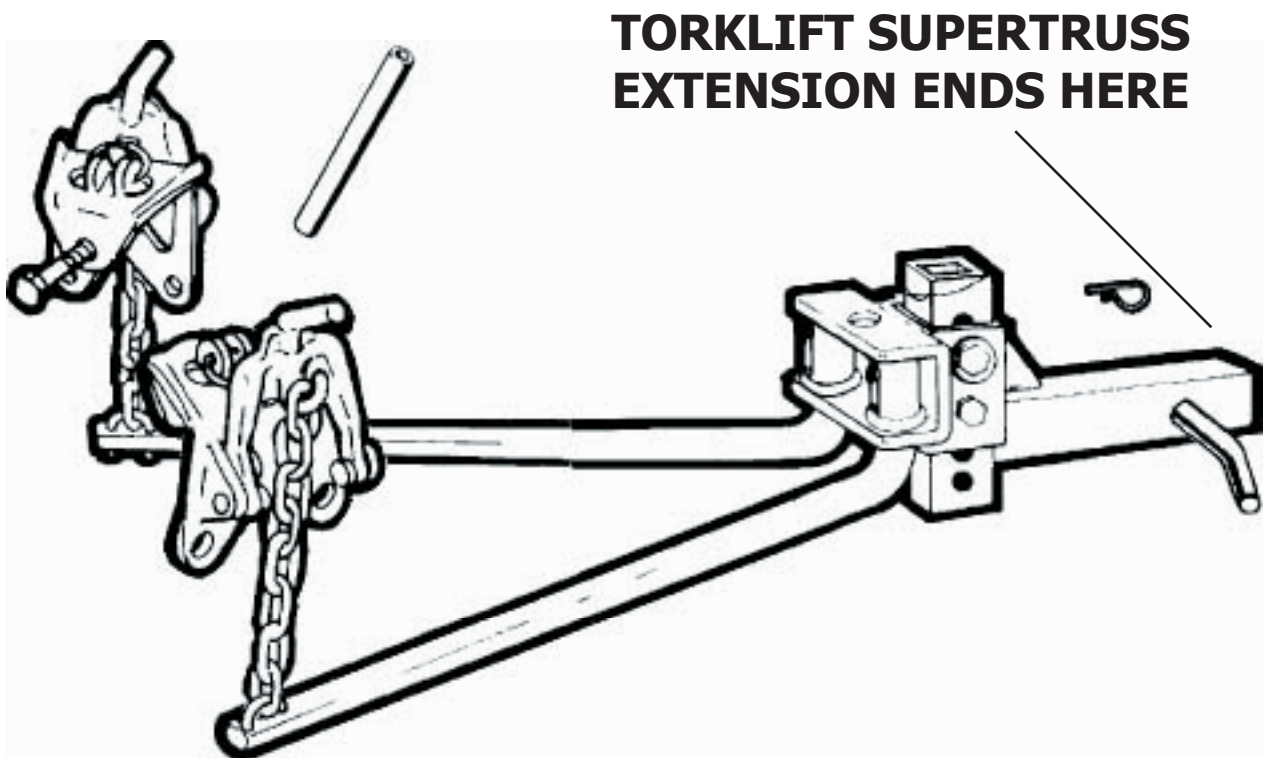

**THIS TYPE OF HITCH IS REQUIRED IN  
ADDITION TO YOUR SUPERHITCH TO  
OBTAIN THE MAXIMUM RATED CAPACITY.  
INCORRECT INSTALLATION OF THE WEIGHT  
DISTRIBUTION SYSTEM MAY RESULT IN  
DAMAGE TO YOUR VEHICLE.**

## **WEIGHT DISTRIBUTION - CONTINUED**

When towing trailers that exceed the dead weight rating on your extension, it is mandatory to use a weight distributing type hitch/ball mount and related hardware (SPRINGBARS, QUICK HOOKUP CLIPS, ETC).

Not all weight distribution systems are rated at the same capacity. Your weight distributing ball mount and bars must be rated at least 100 lbs higher in regards to tongue weight than the pre-existing tongue weight of your trailer **when fully loaded.**

**It is of critical importance** that your weight distribution system is not only rated high enough to match your existing tongue weight, but that you also have the system set up correctly.

We have supplied a formula to assist you in accurately determining the tongue weight load of your trailer when fully loaded. After accurately determining your tongue weight and making sure that your weight distribution system is rated high enough, your next step is to ensure the set up of the system



## PLEASE READ CAREFULLY

**1.** The height of the ball must be determined before any assembly work can be started. To get ball height, measure trailer from ground level to top of ball coupler. Be sure trailer is parallel to ground. With your camper on your truck, fully loaded with gear and overloads adjusted, slide the weight distribution ball mount into the SuperHitch extension. Be sure the truck is on level ground. The measurement from ground to top of ball should be 1 1/2" higher than the level height of trailer top of ball measurement.

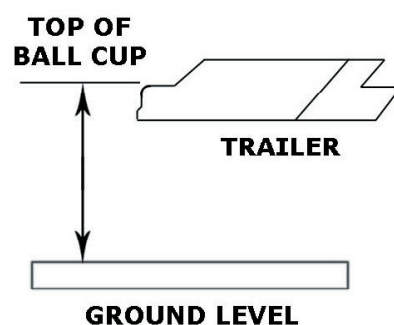

- 2.** After ball height has been determined, write down the ascertained height. EXAMPLE: Measured top of coupler height was 17" from ground, ball height should be 18 1/2".
- 3.** Slide the shank into the sleeve receiver, insert hitch pin and spring clip. With the ball attached to the ball mount, slide the ball mount up or down the shank until nearest dimension is obtained and the holes line up with shank. Insert the bolt in the bottom hole first (rest hitch head).
- 4.** The rivet and 8 spacer washers are supplied in order to gain the correct downward angle of the spring bars. Insert rivet, and depending on the angle or the slope of bars that must be gained, use either 8 or the least amount of washers necessary in order to establish correct angle. The rivet and its accompanying washers are placed in the 1/2" hole between the "U" on the ball mount to acquire desired angle of spring bar. Once the spring bar angle has been determined, insert the top bolt with a flat washer, both sides, the lock washer and nut to secure the unit in correct position. Insert the bottom bolt, use the lock washer and nut. Before tightening the bolts, lock the set screw. After the first day of towing, check set the screw for tightness.

**See the following page for further illustrated diagrams.**

# ILLUSTRATED DIAGRAMS

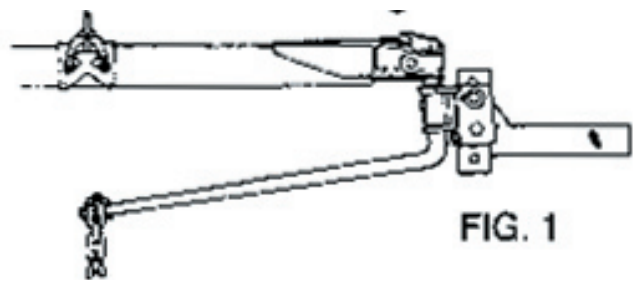
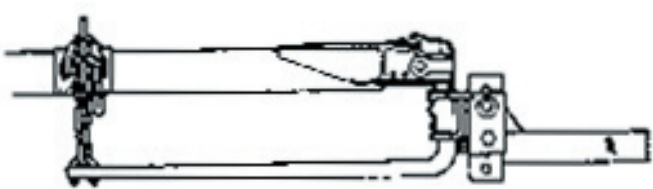
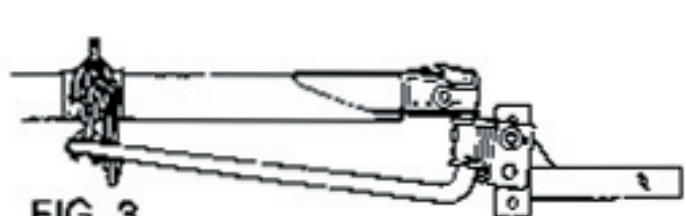
<p><b>BEFORE HOOKING UP:</b> Spring bar should hang down on a 10-13 degree angle when ball mount has been tilted back at 6-8 degree angle.</p>	 <p>FIG. 1</p>
 <p>FIG. 2</p>	<p><b>AFTER HOOKING UP:</b> Spring bar should be parallel with trailer frame, or a slight angle up or down. Slight bow or bend in bar is normal.</p>
<p><b>WRONG:</b> Readjust degree of tilt on ball mount if you have more than five links of chain hanging free. The number of links should be the same on both bars.</p>	 <p>FIG. 3</p>

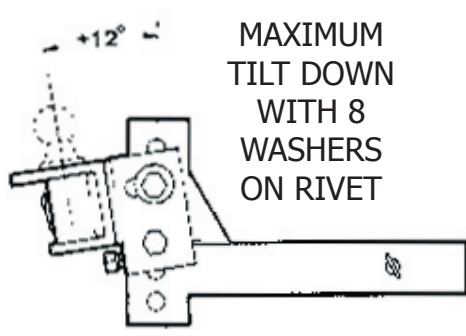
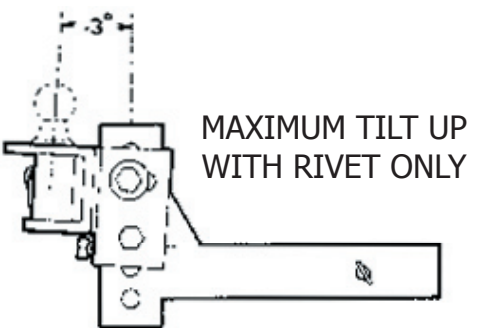
<p>EACH WASHER LOWERS CHAIN END OF SPRING BAR APPROX 1 1/2".</p>	 <p>+12°</p> <p>MAXIMUM TILT DOWN WITH 8 WASHERS ON RIVET</p>	 <p>-3°</p> <p>MAXIMUM TILT UP WITH RIVET ONLY</p>
--	--	--

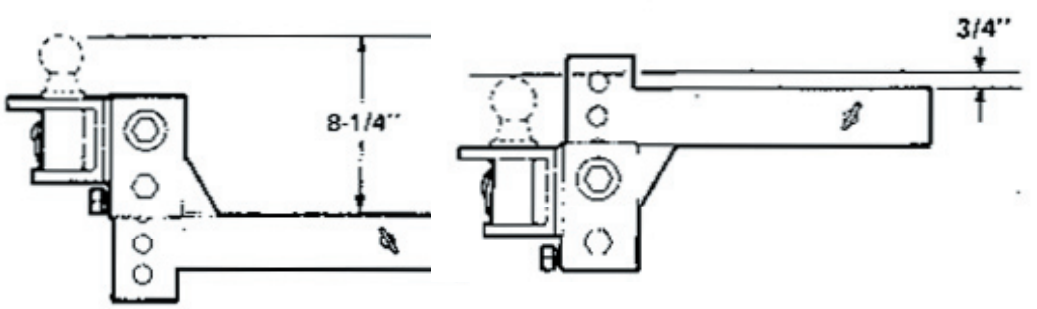
<p>BOLT-TOGETHER BALL MOUNT HAS 7 1/2" ADJUSTMENT, EACH ADJUSTMENT IS 1 1/4" EXTRA HY-LOW SHANKS AVAILABE IF NEEDED.</p>	 <p>8-1/4"</p> <p>3/4"</p>
--	--

# THESE STEPS MAY VARY DEPENDING ON WEIGHT DISTRIBUTION HITCH MANUFACTURER

1. Put the ball mount into the sleeve, insert the 5/8" hitch pin using spring clip to lock the pin into place - hitch balls are not furnished with the hitch as there are several sizes, normally they are supplied or may be purchased from the dealer to match the coupler of the trailer. Ball shank bushings are supplied to reduce the size of the ball hole in the hitch down to 1" if needed.

2. Measure the towing vehicle ball height before adding load to towing vehicle. Hook the trailer to the truck. Lock on the ball. To make hooking up easier and safer, raise front of the trailer and back of the towing vehicle above level with the trailer tongue jack. This removes some of the tension by reducing the distance between the spring bar and hook-up arm.

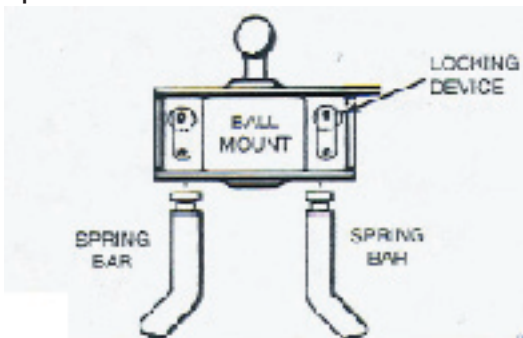

3. This step may vary depending on the manufacturer. The spring bars can be inserted into either side of the ball mount (there is no 'right' or 'left' bar). To insert and lock spring bar in socket, hold the bar under socket and push up. The spring bar will automatically be locked into position by the spring bar locking device (check to make sure the bar is locked in by moving it up and down at the chain end). To remove the spring bars, just pull out the locking device or swing the bar around under the bumper and it will drop free.

4. To find correct location on trailer frame for quick hook-up bracket, hold the chain straight up and down and free of twist. Center hook-up bracket on frame and tighten. Set the screw 1/4 turn only. **DO NOT OVERTIGHTEN.** On straight tongue trailers a poli-tongue adapter is necessary.

5. You are now ready to put tension on the spring bars. When using the quick hook-up, lower the arm and slip link of chain over hook. Insert hook-up handle over the end of the quick hook-up arm. Lift and flip over center (see fig A).

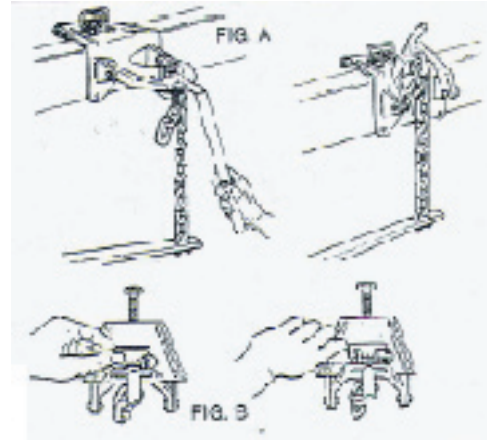

**CAUTION: MAKE SURE THAT THE HOOK-UP ARM IS COMPLETELY SEATED AND THAT THE SPRING BAR IS PUSHED DIRECTLY UNDER THE HOOK-UP CHAIN HOOK.** Now install the hook-up locking clip through locking ears and over hook on hook-up arm (see fig B).

6. Release the trailer tongue jack by adjusting the chain links up or down, the desired load on the bars will be gained. Lock the coupler onto the ball and raise the front of the trailer approximately 3" above level. Attach the chain link to the hook-up clip. It should require 50-100 lbs of force to properly tension the spring bars. Bow or bend in the spring bar is normal.

7. To release tension on the spring bars, raise the front of the trailer and the back of the towing vehicle above level (approx 3") with the trailer tongue jack. Remove the locking clip from the bracket. Insert the handle over arm. Carefully lower the arm with the handle. It will require effort to bring the arm over the center and then to resist the chain tension as the arm rotates downward.

## MAINTENANCE:

Use heavy lubrication such as fibre type wheel bearing grease on the hitch ball and on spring bars inside the ball mount. This is recommended every day. Also keep the hitch painted to prevent rust and check the tightness of bolts regularly. Clean out old grease and do not let it harden inside of the ball mount.

# IMPORTANT CONSUMER INFORMATION ON TOWING

**TOWING EQUIPMENT OWNERS:** Make sure all of the operators of your equipment read and understand this information before towing. Save for reference. This will help you properly select, use and maintain your towing equipment. Refer to your owner's manuals for your tow vehicle, trailer and other parts of your towing system. Learn the capabilities and limitations of each part. The **GROSS TRAILER WEIGHT** and **TONGUE WEIGHT** are two of the most important items to consider. **THESE WEIGHTS MUST NEVER EXCEED THE LOWEST RATING OF ANY PART OF YOUR TOWING SYSTEM.** **GROSS TRAILER WEIGHT** is the weight of the trailer plus all cargo. Measure the **GROSS TRAILER WEIGHT** with the fully loaded trailer on a level surface. The weight is the downward force exerted on the ball by the trailer coupler. Measure the **TONGUE WEIGHT** with the fully loaded trailer on a level surface. The coupler must be at its normal towing height. Use a commercial scale or a bathroom scale. Set up the bathroom scale as shown for heavy tongue

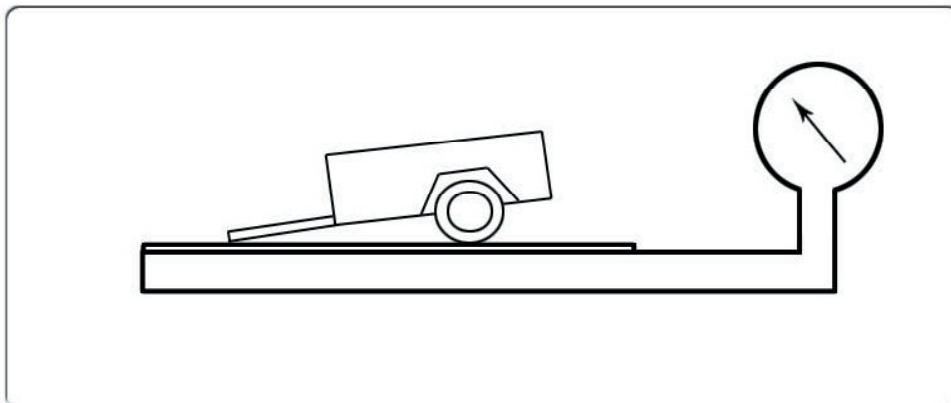

**Method for Measuring Gross Trailer Weight**

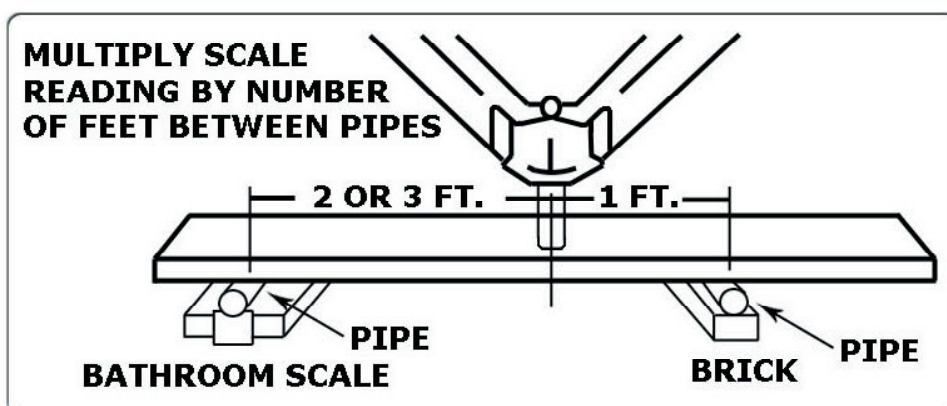

**Method for Measuring Trailer Tongue Weight**

# YOUR TOWING EQUIPMENT

## HITCH BALLS

Select by gross trailer weight rating, mounting platform thickness, hole size and coupler socket size. Platform must be at least 3/8" thick. Hole must not exceed threaded shank diameter by more than 1/16". Use lock washer. Tighten per instructions. When tightened, shank must protrude beyond bottom of nut. Gross trailer weight rating and ball diameter are marked on REESE balls.

## TRAILER COUPLERS

The coupler socket should be smooth, clean and lightly lubricated. Tighten or adjust per coupler manufacturer's instructions.

## SAFETY CHAINS

Connect safety chains properly EVERY TIME YOU TOW. Cross chains under coupler. Attach securely to the hitch or tow vehicle so they cannot bounce loose. Leave only enough slack to permit full turning. Too much slack may prevent chains from maintaining control if other connections separate. Do not let chains drag on the road.

## TRAILER LIGHTS, TURN SIGNALS, ELECTRIC BRAKES AND BREAK AWAY SWITCH CONNECTIONS

Make these safety-critical connections EVERY TIME YOU TOW, no matter how short the trip. Check operation, including electric brake manual control, before getting on the road.

**NO PASSENGERS IN TRAILERS:** NEVER allow people in trailers while towing, under any circumstances.

## SWAY CONTROLS

Sway controls can lessen the effects of sudden maneuvers, wind gusts and buffeting caused by other vehicles. We recommend them for trailers with large surface areas, such as travel trailers. Adjustable friction models can help control trailers with low tongue weight percentage.

## OTHER USEFUL EQUIPMENT

AIR SPRINGS, AIR SHOCKS or HELPER SPRINGS are useful for some hitch applications. A TRANSMISSION COOLER may be necessary for heavy towing. Many states require TOWING MIRRORS on both sides.

## TIRE INFLATION

Check often. Follow tow vehicle and trailer manufacturer's recommendations. Improper tire inflation can cause trailer sway.

# HELPFUL TOWING HINTS

## TRAILER LOADING

Proper loading helps prevent sway. Place heavy object on the floor ahead of the axle. Balance the load side-to-side. Secure it to prevent shifting. Tongue weight should be 10-15 percent of gross weight for most trailers. Too low of a percentage of tongue weight can cause sway. NEVER load the trailer rear heavy - LOAD THE TRAILER HEAVIER IN FRONT.

## DRIVING

The additional weight of a trailer affects acceleration, braking and handling. Allow extra time for passing, stopping and changing lanes. Severe bumps can damage your towing vehicle, hitch and trailer. Drive slowly on rough roads. STOP AND MAKE A THOROUGH INSPECTION IF ANY PART OF YOUR TOWING SYSTEM STRIKES THE ROAD. CORRECT ANY PROBLEMS BEFORE RESUMING TRAVEL.

## CHECK FOR EXCESSIVE SWAY AND ELIMINATE IT

Excessive sway can lead to loss of control. Sway motion should settle out quickly. Sway tends to increase on a downgrade. Starting slowly, increase speed in gradual steps. If sway occurs, adjust your trailer load and equipment. Repeat until the trailer is stable at highway speed. Do this whenever your trailer loading changes.

## IF TRAILER SUDDENLY STARTS TO SWAY

Turbulence from another vehicle, a wind gust or a downgrade can cause sudden sway. So can a shift of the trailer's load or a trailer tire blowout. IF THE TRAILER SWAYS, IT IS THE DRIVER'S RESPONSIBILITY TO ASSESS THE SITUATION AND TAKE APPROPRIATE ACTIONS. Below are suggestions that may apply, depending on conditions:

### DO

- Reduce your speed gradually.
- Hold the steering wheel as steady as possible.
- If your trailer has electric brakes, apply the brakes alone, without using the tow vehicle's brakes.

### DON'T

- Don't hit your brake pedal hard unless absolutely necessary. A "jack-knife" can result.
- Don't try to steer out of the sway condition. Sudden or violent steering can make it worse.
- Don't speed up. Sway increases as you go faster.
- Don't continue towing a trailer that tends to sway. You may lose control during an emergency maneuver or if the conditions listed above occur.

# **TORKLIFT LIMITED WARRANTY**

322 N RAILROAD AVE KENT, WA 98032 (800) 246-8132

## **LIMITED WARRANTY**

TorkLift warrants its hitches, custom hitch receivers, frame mounted tiedowns and FastGun Turnbuckles from date of purchase against defects in material and workmanship under normal use and service, ordinary wear and tear excepted, for the ownership life of the original consumer purchaser. TorkLift will replace **FREE OF CHARGE** any part that proves defective in material or workmanship when presented to TorkLift, **TRANSPORTATION CHARGES PREPAID**, at the address above. **THIS WARRANTY IS LIMITED TO DEFECTIVE PARTS REPLACEMENT ONLY. LABOR CHARGES AND/OR DAMAGE INCURRED IN INSTALLATION OR REPLACEMENT AS WELL AS INCIDENTAL AND CONSEQUENTIAL DAMAGES CONNECTED THEREWITH ARE EXCLUDED.** This warranty does not include the finish or paint on our products. Rusting, cracking or peeling of the finish is also excluded. Some states do not allow the exclusion or limitation of incidental or consequential damages, so the above limitation or exclusion may not apply to you. Any damage to the hitch, custom hitch receiver or frame mounted tiedowns as a result of misuse, abuse, neglect, accident, improper installation or any use violative of instructions furnished by us **WILL VOID THE WARRANTY.** This warranty gives you specific legal rights, and you may also have rights which vary from state to state. With warranty service or performance, you may be able to go to a small claims court, a state court or a federal district court.



**322 NO. RAILROAD    PHONE (800) 246-8132  
KENT, WA 98032    FAX    (253) 854-8003**

**OR VISIT OUR WEBSITE: [WWW.TORKLIFT.COM](http://WWW.TORKLIFT.COM)**

Dear Valued Customer,

Thank you for making TorkLift your choice for truck, camper packages and accessories for your vehicle. By choosing TorkLift products, you have chosen a company that has been serving the RV industry for nearly 30 years and whose name has become synonymous with strength, quality and advanced design and installation.

Please take a few moments of your time to complete the Product Registration Warranty Card on the next page and send it back to us at the address listed above. When registering your newly purchased TorkLift products, you can be assured that your contact information is secure and that you and your product are getting the attention and respect that you deserve.

Thank you again for choosing TorkLift quality products.





## OFFICIAL WARRANTY REGISTRATION CARD

PLEASE FILL OUT THIS FORM COMPLETELY AND RETURN TO TORKLIFT WITHIN 30 DAYS OF PURCHASE, ACCOMPANIED BY A COPY OF YOUR ORIGINAL RECEIPT

TODAY'S DATE: \_\_\_\_\_

### 1. PART(S) PURCHASED

PART #: \_\_\_\_\_ PART #: \_\_\_\_\_  
PART #: \_\_\_\_\_ PART #: \_\_\_\_\_

### 2. PURCHASER INFORMATION

NAME: \_\_\_\_\_

ADDRESS: \_\_\_\_\_

CITY: \_\_\_\_\_ STATE: \_\_\_\_\_ ZIP / POSTAL CODE: \_\_\_\_\_

PHONE: \_\_\_\_\_ EMAIL: \_\_\_\_\_

### 3. TRUCK INFORMATION

YEAR: \_\_\_\_\_ MAKE: \_\_\_\_\_

MODEL: \_\_\_\_\_ BED LENGTH: \_\_\_\_\_

### 4. CAMPER INFORMATION

YEAR: \_\_\_\_\_ MAKE: \_\_\_\_\_ MODEL: \_\_\_\_\_

### 5. DEALER INFORMATION

PURCHASED FROM: \_\_\_\_\_

ADDRESS: \_\_\_\_\_

CITY: \_\_\_\_\_ STATE: \_\_\_\_\_ ZIP / POSTAL: \_\_\_\_\_

INSTALLED BY:  OWNER  ABOVE DEALER  ANOTHER DEALER

IF ANOTHER DEALER, WHO: \_\_\_\_\_