

Instructions for Prodigy® Brake Control

For 2, 4, 6 and 8 brake applications

READ THIS FIRST:

Read and follow all instructions carefully before installing or operating the Prodigy. Keep these instructions with the brake control for future reference.

Components of the Brake Control

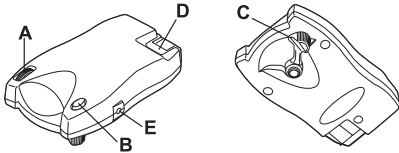

- A. Power Knob
- B. Boost Button
- C. Manual Knob
- D. Connector (For Wiring Harness)
- E. Mounting Hole (1 per side)

Important Facts to Remember

1. Do not mount or activate RF generating items (cell phones, two way radios) near (less than 12") the brake control.
2. **CAUTION** Reversing the connection to a breakaway battery on the trailer will destroy the Prodigy.
3. **CAUTION** Disconnect trailer plug from the tow vehicle prior to testing a breakaway switch or you may destroy the Prodigy.
4. The Prodigy employs an inertial sensor. It senses deceleration and generates an output that is based on deceleration, thus the term "Proportional Braking".
5. The Prodigy will "HOLD" your trailer with 25% of power setting while you are at a standstill with brake pedal applied for longer than 5 seconds.
6. The Prodigy will brake proportionally in reverse. It will apply the appropriate brake voltage based on deceleration.
7. For Technical Assistance and Warranty Information call: 1-888-785-5832 or www.tekonsha.com.
8. **WARNING** The Gross Combined Weight Rating (GCWR) must never exceed the vehicle manufacturers recommendation.
9. **CAUTION** This control is not designed for use with electric-hydraulic trailer brake systems.

Installation Guide

WARNING The Prodigy must be mounted from 0 degrees to 70 degrees nose up. (See Below).

In hilly terrain it is advisable to leave a margin at either extent to keep bars from coming on when going up and down hills. When mounted near level the lower bars may come on during heavy acceleration (see Trouble-shooting Chart). This will not affect the performance during braking.

Failure to install the Prodigy within these constraints may cause impaired performance.

Wiring Brake Control

Your Prodigy brake control has a new and unique connector located at the back of the control. This connector allows you two options to wire your brake control.

Option 1:

Use Pigtail Wiring Harness included. This harness can be installed by following the Generic Wiring Guide.

Option 2:

Use a Ford, Dodge or GM specific wiring harness. If your vehicle came with a factory tow package that included a 7-way connector, you can purchase a Tekonsha OEM wiring harness with the Prodigy connector on one end and your specific vehicle's connector on the other. See Generic Wiring Guide, for location of your vehicle's connector.

Display Readings after Wiring the Prodigy

After successfully wiring your Prodigy you should see the following on the two-digit display:

- Power to Prodigy without trailer connected.

n.c.	Displays for 15 seconds then changes to:	.
------	--	---
- Power to Prodigy with trailer connected and Boost feature not engaged.

.c	Boost feature engaged.	.c.
----	------------------------	-----
- Manual Knob Activated without trailer

n.c.

- Manual knob activated (with trailer), 5.4 denotes a hypothetical power output. This value is set using the power knob. Range is 0.0 to 13 volts. This is an indication of voltage output to electric brakes.

5.4

- Power to Prodigy but display is in power saving mode (no motion or activity for at least fifteen minutes).

(Blank Display)

Mounting the Prodigy

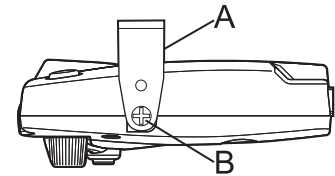
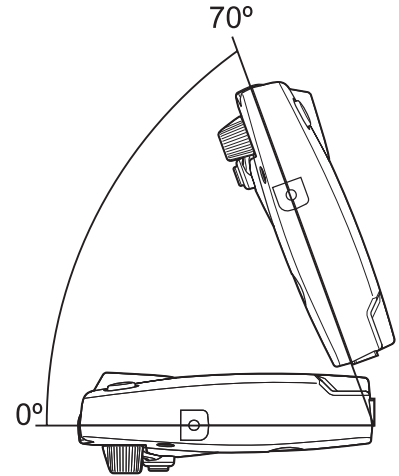

Traditional Bracket Mount

- A. Mounting Bracket
- B. #8 X 3/8" Machine Screw with Internal Tooth Washer

1. **CAUTION** Drilling or use of longer screws may damage unit.
2. Securely mount bracket to a solid surface.
3. Insert supplied #8 x 3/8" machine screws on each side into the mounting holes.
4. Adjust control to desired position and tighten screws until snug.

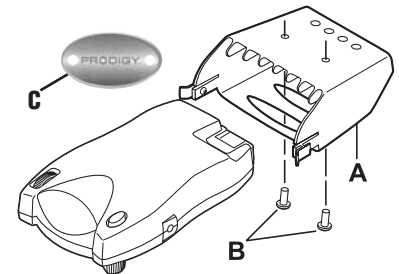

Under Dash Pocket Mount

- A. Pocket Mount
- B. #6 X 1/2" Self Tapping Screws
- C. Pocket Mount Template

1. Securely mount *Pocket Mount* to a solid surface using supplied #6 X 1/2" Self Tapping Screws.
2. Insert Prodigy Brake control.
3. Plug in connector.

Instructions for Prodigy® Brake Control (continued)

NOTE:

1. Front of the Prodigy must be horizontal, *see below*.
2. The Prodigy must be parallel to direction of travel, *see below*.

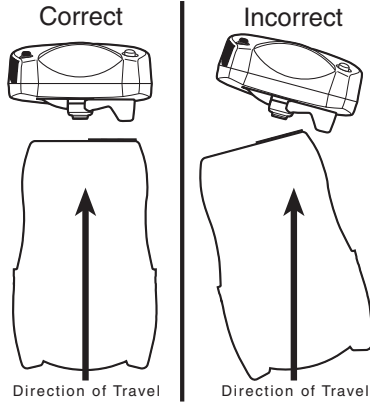

Automatic Leveling of the Sensor

The Prodigy will automatically acquire the proper level setting. It will also automatically adjust as you travel up or down hills.

Adjusting the Power to the Trailer Brakes (Prior to setting Boost)

Once the control has been securely mounted within the 0 to 70-degree range, it is necessary to set the power needed to stop the trailer during a braking event.

1. Connect trailer to tow vehicle.
2. With engine running hold manual full left and set Power Knob to indicate 6.0
3. Drive tow vehicle and trailer on a dry level paved surface at 25 mph and fully apply manual knob.
 - ✓ If trailer brakes lock up:
 - ☐ Turn power down using power knob.
 - ✓ If braking was not sufficient:
 - ☐ Turn power up using power knob.
4. Repeat Step (3) until power has been set to a point just below wheel lock up or at a sufficient force as to achieve maximum braking power.
5. Using the brake pedal, make a few low speed stops to check the power setting. Trailer braking is initiated and terminated via the stoplight switch. When the brake pedal is released, trailer braking will cease.

Boost Setting

The boost button was designed to allow a more aggressive setting for your trailer brakes and is available in three levels - [*b.1*], [*b.2*], [*b.3*]. Each incremental boost setting increases the sensitivity of the Prodigy's inertial sensor, enhancing the participation of the trailer brakes during a braking event.

The first press on the boost button displays the current setting. Boost is advanced to the next level by continuing to press the boost button.

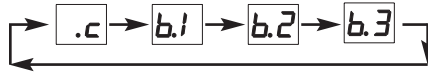

Five seconds after setting the boost level, the display will show



indicating **Boost On** by the right most decimal.

For example: With the boost off, [*.c*], during a braking event, the power to the brakes starts out at zero and increases with deceleration.

With the boost on level 1,

(Boost Setting continued)

[*b.1*], during a braking event, the power automatically starts out at approximately 13% of the power setting and increases with deceleration. **With the boost on level 2**, [*b.2*], or **with the boost on level 3**, [*b.3*], during a braking event, the power automatically starts out at approximately 25% of the power setting and increases with deceleration. Some cases where you might want to use the boost button:

- You like the trailer braking to 'LEAD' the tow vehicle's braking
- Towing a full vs. empty trailer
- Degraded brake performance (most electric brakes require manual adjustment - see Appendix A or a dealer for adjustment or repair)

NOTE: Boost not intended to be used to take place of trailer brake adjustment or repair.

See the chart below for recommended "Boost" settings (indicated with **X**) for typical Trailer to Vehicle weight relationships.

Select your boost setting based on your towing situation, driving preference and condition of your trailer brakes.

Typical Boost Settings For Optimal Performance (with properly adjusted trailer brakes*)

TRAILER WEIGHT compared to VEHICLE WEIGHT	.c	b.1	b.2	b.3
	BOOST "OFF" ↻ INCREASING BOOST LEVEL ↻			
Trailer weighs LESS than Vehicle	X	X		
Trailer weighs APPROXIMATELY SAME as Vehicle	X	X	X	
Trailer weighs UP TO 25% MORE than Vehicle		X	X	X
Trailer weighs UP TO 40% MORE than Vehicle			X	X
Trailer weighs OVER 40% MORE than Vehicle	⚠ WARNING Do not exceed Gross Combined Weight Rating (GCWR)			X

* Increased Boost setting may be needed if trailer brakes are worn, see Appendix A or a dealer for brake adjustment or repair.

NOTE:

1. Always warm the trailer's brakes before setting the power. Warm trailer brakes tend to be more responsive than cold brakes. To warm trailer brakes, drive a short distance (1/4 mile) at 45 MPH with manual lever engaged enough to cause trailer braking at a low level.
2. **⚠ WARNING** The power should never be set high enough to cause trailer brakes to lock up. Skidding trailer wheels can cause loss of directional stability of trailer and tow vehicle.
3. The power may need to be adjusted for different load weights and road conditions.
4. Not all trailer brakes will lock up due to various conditions. However, inability to lock up the brakes generally indicates the need for an inspection to determine the cause.
5. When the power is set correctly you should feel unified braking between the trailer and tow vehicle.
6. **⚠ WARNING** Boost setting will be cleared under abnormally low battery conditions. Check boost setting after starting vehicle.

Instructions for Prodigy® Brake Control (continued)

Reverse

When backing a trailer you can cancel “BOOST” and “HOLD” for a period of three minutes. This can be accomplished by pressing the boost button continuously for five seconds with the brake pedal depressed. The display will indicate:



(Reverse continued)

(If “boost” was active, the right hand decimal point will also be on.) After three minutes the “BOOST” and “HOLD” features will automatically return to your previous settings.

NOTE:

Returning to your previous settings prior to three minutes can be accomplished by pressing the boost button.

Troubleshooting Chart

Display	Situation	Probable Cause
	Flashes 2 times a second or a steady display.	Trailer is connected and Prodigy loses connection to battery ground.
	Flashes 2 times per second.	Prodigy “sees” an overload condition during operation.
	Flashes 2 times per second.	1. Brake wire sees short during idle condition. 2. Use of some test lights or non-Tekonsha testers can cause this problem.
	The lower two bars flash	Prodigy is mounted at too low an angle.
	The upper two bars flash	Prodigy is mounted at too high an angle.
	Flashes for 15 seconds	1. Trailer not connected to tow vehicle. 2. Trailer connected with open circuit on brake line. 3. Trailer connector disconnected or corroded. 4. Loss of trailer brake magnet ground.
	No display with manual or pedal activation.	1. Loss of power to Prodigy. 2. Loss of ground to Prodigy.
	No display until activation	Prodigy is in power-saving mode due to no motion for fifteen minutes.
	No braking	Power control set to 0.
	Power interruption while brake pedal is depressed.	

Appendix A: Trailer Brake Adjustment**

Brakes should be adjusted after the first 200 miles of operation when the brake shoes and drums have “seated” and at 3000 mile intervals, or as use and performance requires. The brakes should be adjusted in the following manner:

- Jack up trailer and secure on adequate capacity jack stands. Follow trailer manufacturers recommendations for lifting and supporting the unit. Check that the wheel and drum rotate freely.
- ⚠ WARNING** Do not lift or support trailer on any part of the axle or the suspension system.
- Remove the adjusting hole cover from the adjusting slot on the bottom of the brake backing plate.
- With a screwdriver or standard adjusting tool, rotate the starwheel of the adjuster assembly to expand the brake shoes. Adjust the brake shoes out until the pressure of the linings against the drum makes the wheel very difficult to turn.

Note: With drop spindle axles, a modified adjusting tool with about an 80 degree angle should be used.

- Then rotate the starwheel in the opposite direction until the wheel turns freely with a slight lining drag.
- Replace the adjusting hole cover and lower the wheel to the ground.
- Repeat the above procedure on all brakes.

⚠ WARNING Never crawl under your trailer unless it is resting on properly placed jack stands.

Follow the trailer manufacturers recommendations for lifting and supporting the unit. Do not lift or place supports on any part of the suspension system.

**Note: Trailer Brake Adjustment procedures courtesy Dexter Axle.