



PROPORTIONATE TOWED CAR BRAKING SYSTEM

***BrakeMaster 9000 and 9060
Second Motorhome Kit***
part number 98300

Installation Instructions



Quality Towing Systems since 1974
ROADMASTER, Inc. • 5602 N.E. Skyport Way • Portland, OR 97218
800-669-9690 • Fax 503-288-8900 • roadmasterinc.com

AIR COMPRESSOR

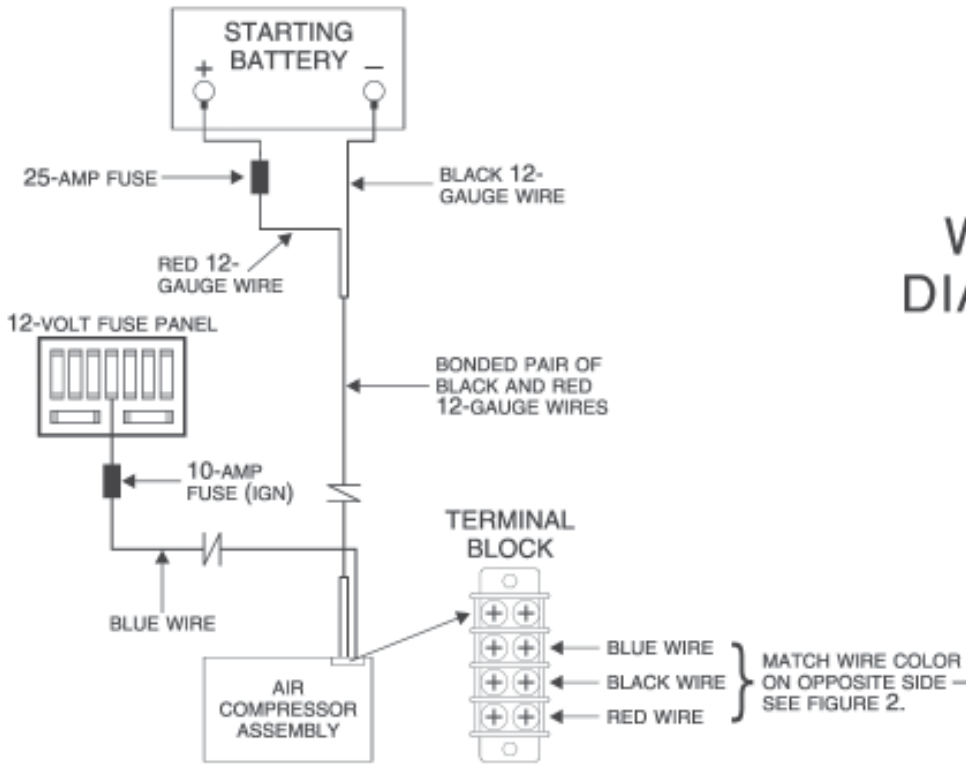

WIRING DIAGRAMS

PROPORTIONING VALVE

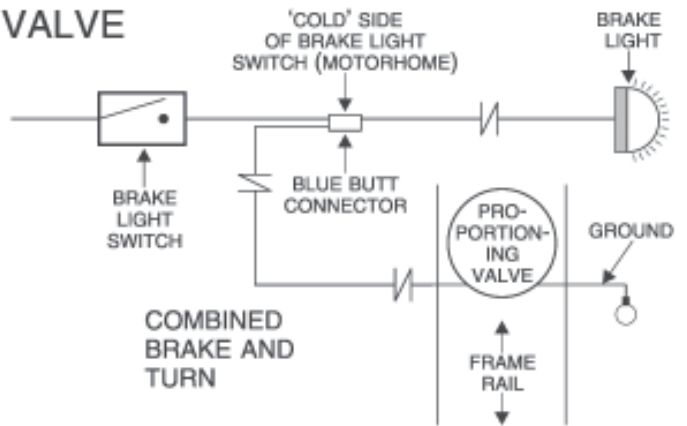
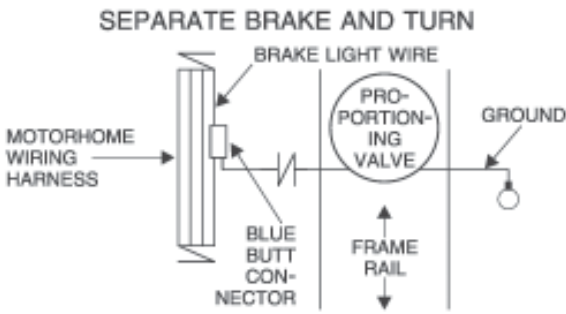

MOTORHOME MONITOR

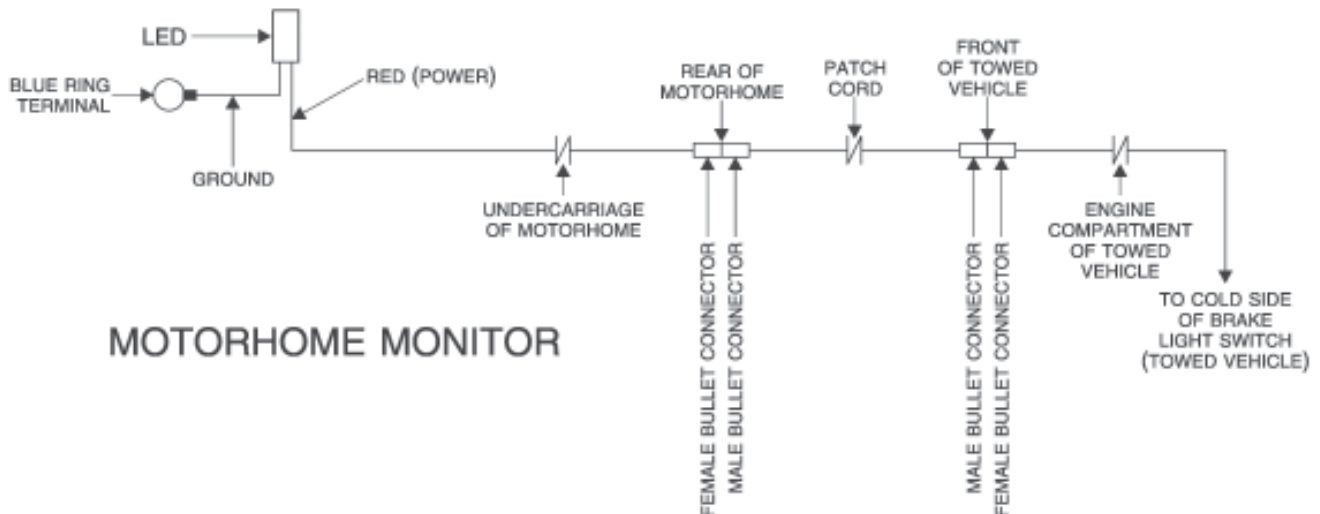

WELCOME TO THE ROADMASTER FAMILY!

These instructions have been prepared to acquaint you with the installation of your BrakeMaster second motorhome kit, and to provide you with important safety information.

Read these instructions, as well as the owner's manual and all accompanying literature, completely. Understand how to install and operate your BrakeMaster, and carefully follow the instructions and safety precautions.

Your BrakeMaster second motorhome kit has a one-year limited warranty. To qualify for your warranty, fill out and return the enclosed product registration card within 30 days of purchase.

We thank you for your patronage and greatly appreciate your discerning taste.

TABLE OF CONTENTS

Wiring diagrams	inside front cover	Bleed the brakes	9-10
Safety definitions	1	Wire the proportioning valve.....	11
Before you begin the installation (installer's checklist)	2	Install the air lines.....	12
Wire the air compressor.....	2-4	Install the motorhome monitor system	13
Install the proportioning valve	5-8	Final connections and system test	14-15
		Troubleshooting	16-17

IMPORTANT NOTICE!

Safety Definitions

Statements in these instructions identified as follows are of special significance:



WARNING

WARNING indicates a potentially hazardous situation which, if not avoided, could result in property damage, serious personal injury, or even death.

Red type is used to emphasize warnings of particular significance.



CAUTION

CAUTION indicates a potentially hazardous situation which, if not avoided, may result in property damage, or minor or moderate personal injury.

Red type is used to emphasize cautions of particular significance.

CAUTION

CAUTION used without the safety alert symbol indicates a potentially hazardous situation which, if not avoided, may result in property damage.

Red type is used to emphasize cautions of particular significance.

NOTE

Refers to important information and is placed in italic type. It is recommended that you take special notice of these items.

BEFORE YOU BEGIN THE INSTALLATION...

1. Check online at the ROADMASTER website – www.roadmasterinc.com – for vehicle-specific information. Select 'Vehicle-Specific Info,' enter the motorhome make, model and year, then select 'Braking Systems.'

2. If the motorhome brake line has metric fittings it will be necessary to use a metric-to-English converter (ROADMASTER part number 357180-00, M12 x 1 metric/standard T-fitting) to attach the proportioning valve. This part is not supplied in the kit; contact ROADMASTER.

3. If the motorhome has a one-piece brake line (i.e., there are no brake line unions), or if the brake line unions are difficult to access, a short length of steel brake line will be necessary to connect the proportioning valve. (See "Install the Proportioning Valve.") This section of steel brake line is not supplied; contact an auto parts store.

WARNING

These instructions pertain to the initial installation of the second motorhome kit only. Installation instructions for the complete BrakeMaster system (including instructions for all components in the towed vehicle) are contained in the original installation instructions.

Operating instructions for the BrakeMaster system are contained in the owner's manual.

For the most recent versions of the instructions and manual, visit www.roadmasterinc.com.

Read the appropriate instructions before installing or operating the BrakeMaster system. Failure to understand how to install or operate BrakeMaster could result in property damage, personal injury or even death.

WIRE THE AIR COMPRESSOR

1. Before wiring the air compressor (Figure 1), first chose a mounting location – the air compressor assembly must be installed in a clean, dry area (ideally, a storage compartment), within 20 feet of the motorhome starting battery.

The compressor is attached with four screws – one at each corner of the air compressor housing. The surface and underlying material at these four points must provide sufficient support to hold the compressor firmly in place.

The compressor may be mounted horizontally or vertically; however, it must be mounted so that the drain valve (Figure 1) is pointing down. Condensa-

tion in the air tank must be drained periodically, through this valve. A short length of rubber hose is included for this purpose – the hose can be attached to the valve and routed to the exterior of the motorhome. If possible, chose a mounting location for the compressor where a ½" hole can be drilled near the drain valve, through to the exterior of the motorhome.

CAUTION

Do not mount the air compressor...

- in a slide-out, or near moving components – the wiring and/or the compressor may detach.

continued on next page

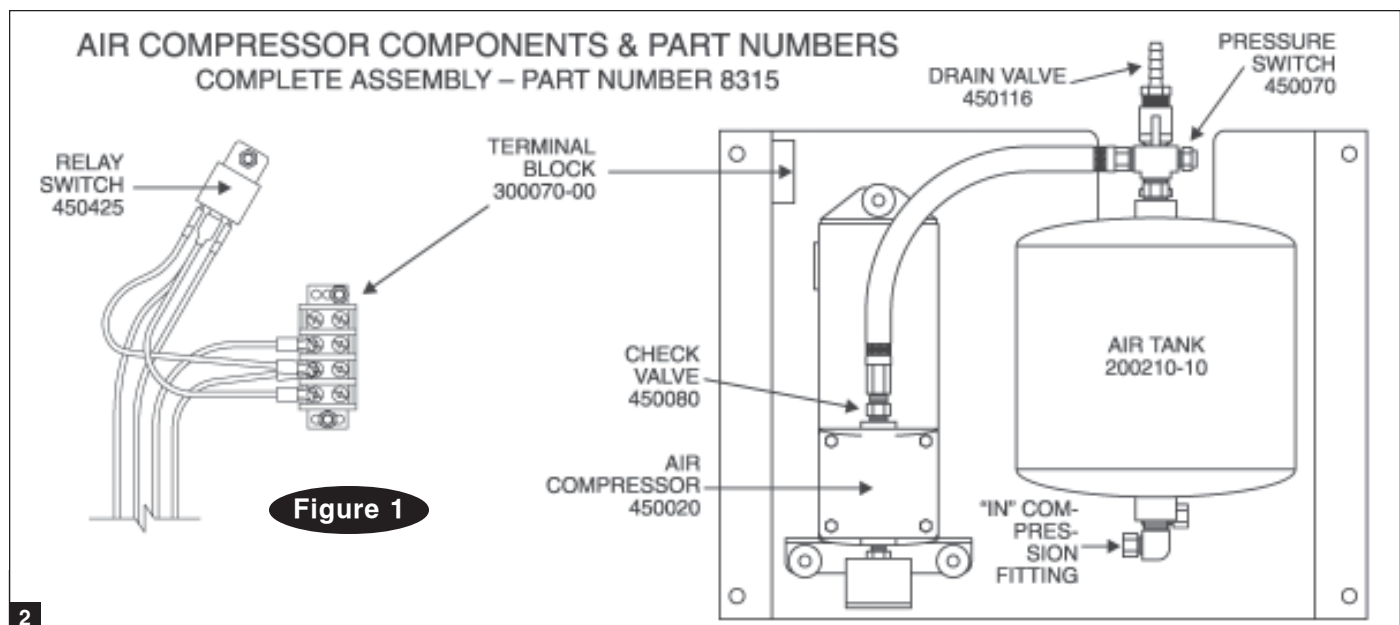

WIRE THE AIR COMPRESSOR

continued from preceding page

- near any heat source such as the engine, exhaust system or muffler – excessive heat will damage the wiring, tubing or other components, which will cause the compressor to fail.

- where it will be exposed to the elements – if the air compressor is mounted near the front grille, for example, it may draw an excessive amount of dirt, dust or road debris into the air tank and then into the air lines, which may damage components connected to the air lines.

Failure to follow these instructions may cause non-warranty damage to the air compressor, the air cylinder, or other components of the braking system.

2. Position the air compressor at the mounting location you have chosen. Using the four pre-drilled holes in the housing (one at each corner) as templates, drill four pilot holes. Before drilling, make certain you will not damage any components on the other side.

Do not attach the air compressor now – in most cases, it will be considerably easier to connect the wiring (and, later, the air lines) with the compressor loose.

3. Route the bare end of the bonded pair of black and red 12-gauge wires from the motorhome starting battery to the air compressor. (If the motorhome has more than one starting battery, route the wire from either battery.)

CAUTION

Do not use an auxiliary (“house”) battery as a power source for the air compressor – the auxiliary battery may be near capacity. Any additional power draw may blow the fuse(s) to electrical components already connected to the auxiliary battery.

Avoid moving parts (slide-outs, sliding generators, sliding battery trays, etc.), sharp edges or “hot” components, such as the engine or exhaust system, as you route the wire from the starting battery to the air compressor. Where appropriate, use one or more

of the included wire ties to secure the wire in place.

4. At the air compressor, cut the bonded pair of black and red wires to length. Using one of the small ring terminals, attach the red wire to the terminal block screw opposite the pre-attached red wire (Figure 2.)

Next, use another small ring terminal to attach the black wire to the terminal block screw opposite the pre-attached black wires (Figure 2).

Note: due to manufacturing variances, the pre-attached red and black wires may be mounted to different terminal block screws than those shown in Figure 2. If this is the case, match color to color – red wire opposite red wire, and black wire opposite black wires.

5. At the starting battery, attach the supplied 25-amp fuse to the end of the red wire. A short length of red wire, with a fuse holder at one end and a ring terminal at the other, is provided for this purpose.

Attach the 25-amp fuse as shown in Figure 3.

WARNING

The 25-amp fuse must be installed at the positive terminal, as shown in Figure 3. If a short circuit develops and the fuse is not in place, the battery and other equipment may be damaged; additionally, sparks may cause an electrical fire or a battery explosion.

continued on next page

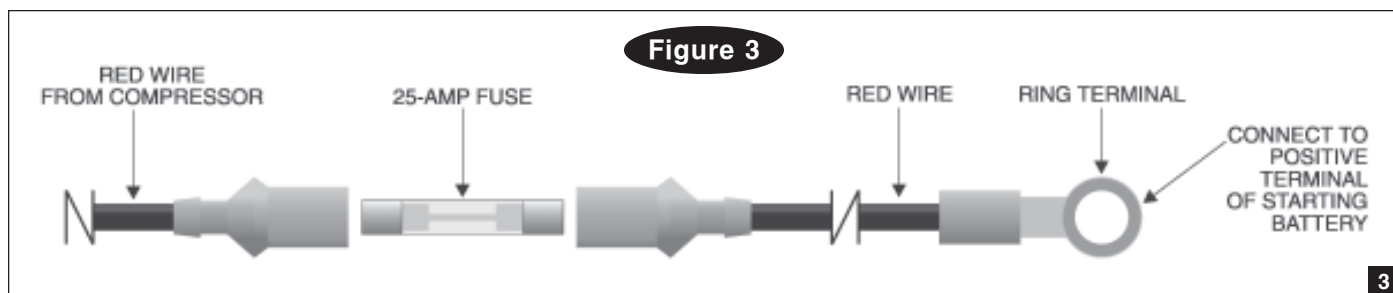
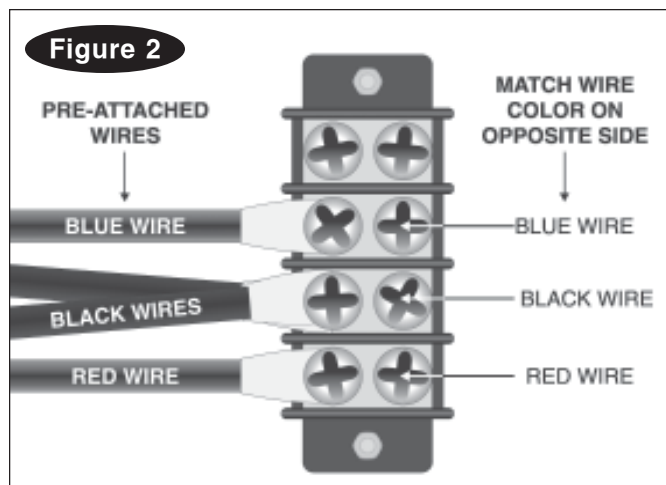

WIRE THE AIR COMPRESSOR

continued from preceding page

Failure to follow these instructions may cause property damage, personal injury or even death.

6. At the starting battery, attach one of the large ring terminals to the end of the black wire.

The red wire will be connected to the positive terminal of the starting battery; the black wire will be connected to the negative terminal of the starting battery. To eliminate the possibility of personal injury or equipment damage, do not connect the wires until the installation is completed.

7. Route the bare end of the supplied length of 14-gauge blue wire from the motorhome's 12-volt fuse panel to the air compressor.

Note: in later steps, two wires will be routed from the rear of the motorhome to the front. Depending on the location of the 12-volt fuse panel and the air compressor, it may be possible to route these two wires at the same time you route the 12-gauge blue wire. See "Wire the proportioning valve" and "Install the motorhome monitor system."

As before, avoid moving parts, sharp edges or "hot" components, such as the engine or exhaust system, as you route the 14-gauge blue wire from the 12-volt fuse panel to the air compressor. Where appropriate, use wire ties to secure the wire in place.

8. At the air compressor, cut the blue wire to length. Using one of the small ring terminals, attach the blue wire to the terminal block screw labeled "blue wire" in Figure 2.

Note: due to manufacturing variances, the pre-attached blue wire may be mounted to a different terminal block screw than the one shown in Figure 2. If this is the case, match color to color – blue wire opposite blue wire.

9. At the motorhome's 12-volt fuse panel, attach the supplied 10-amp fuse to the end of the blue wire. A short length of blue wire, with a fuse holder at one end and a spade connector at the other, is provided for this purpose.

Attach the 10-amp fuse as shown in Figure 4.

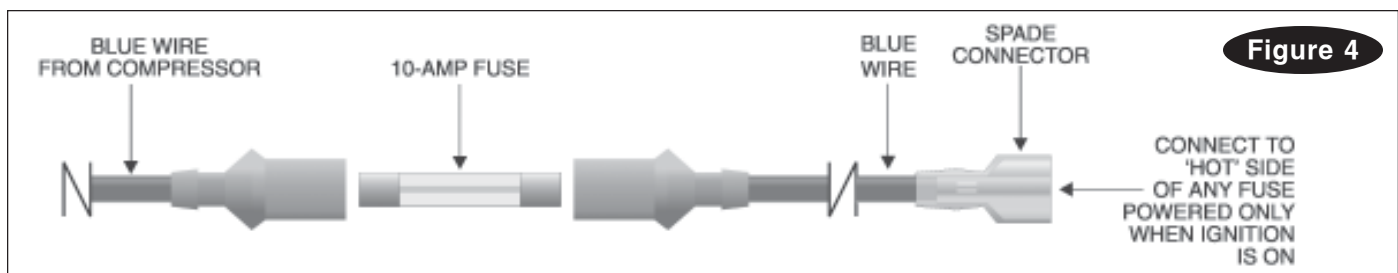

CAUTION

In order to prevent damage from a short circuit, the 10-amp fuse must be within six inches of the electrical connection. If the 10-amp fuse is farther than six inches, a short circuit may cause significant damage to the towed vehicle's electrical system, an electrical fire, or other consequential, non-warranty damage.

10. Use a test light to find the "hot" side of any fuse socket in the 12-volt fuse panel which is powered only when the towed vehicle's ignition is turned on.

Note: the "hot" side of the socket is the one that registers voltage when the fuse is pulled, the ignition switch is on, and the tester is connected between the socket and ground.

Attach the included fuse tap (Figure 5) to the fuse and, with the motorhome's ignition off, replace the fuse.

The blue wire will be connected to this fuse. To eliminate the possibility of personal injury or equipment damage, do not connect the blue wire until the installation is completed.

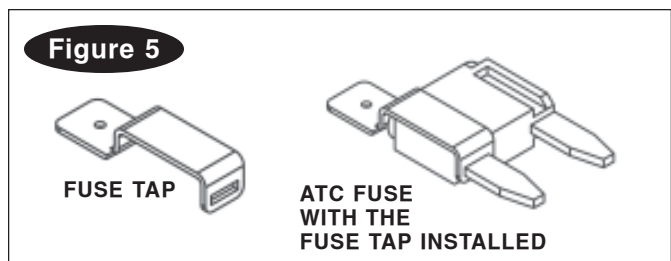

INSTALL THE PROPORTIONING VALVE

WARNING

If the motorhome is raised at any time during the installation, it must be on a hoist or safely and securely supported and blocked.

If the motorhome is equipped with an air suspension system and a line to the air suspension system is inadvertently opened, or if the motorhome's air suspension system is turned off, the motorhome will lower to the ground.

The motorhome may unexpectedly roll forward or backward, especially if it is on an incline, if it is not blocked.

Failure to follow these instructions may cause property damage, personal injury or even death.

1. The proportioning valve (Figure 8) will be installed on the frame of the motorhome chassis, and attached to the brake line.

First, chose a location for the proportioning valve – find the steel brake line that is routed along the

frame. If the motorhome is a Class A, there may be a brake union (Figure 6) every ten to 15 feet, where two sections of brake line are connected. The proportioning valve must be installed near one of these brake unions.

However, some Class A motorhomes, and most Class C motorhomes, have a one-piece brake line, from the front to the rear. There are no brake unions on these motorhomes.

If there are no brake unions, or the brake unions are difficult to access, there are two installation options:

- Follow the steel brake line forward, until it joins with another fitting. This is the point where you can tee into the brake line, as described later.
- Follow the steel brake line back, until the steel brake line joins a rubber brake hose (Figure 7). This junction is the second possible location to tee into the brake line.

continued on next page

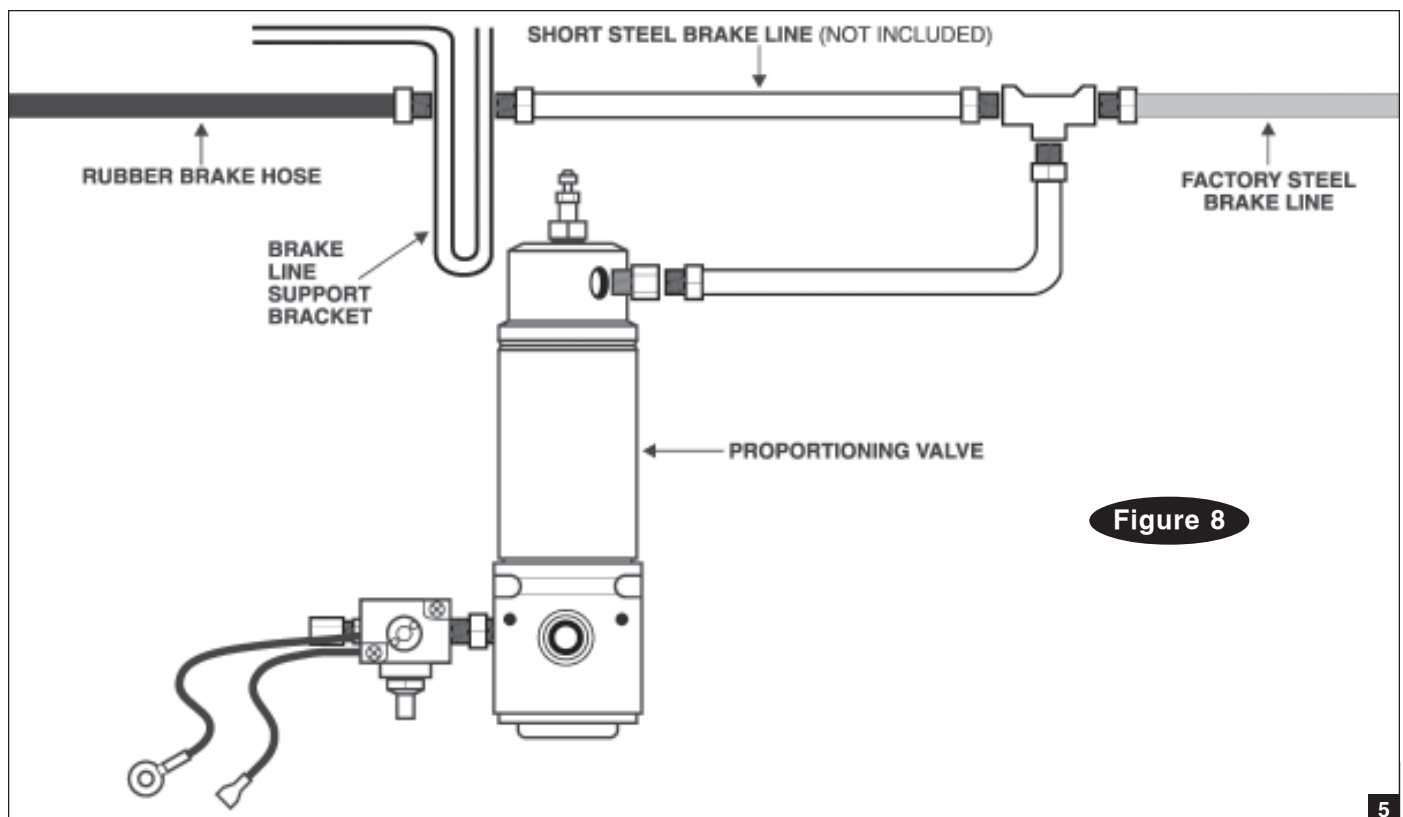
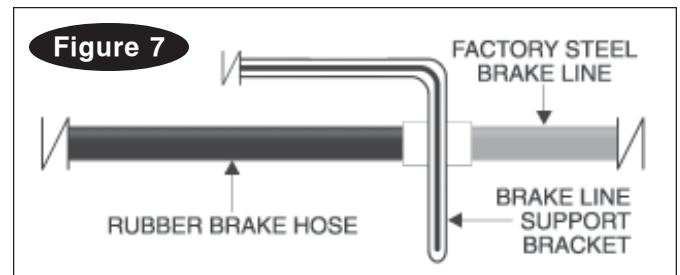
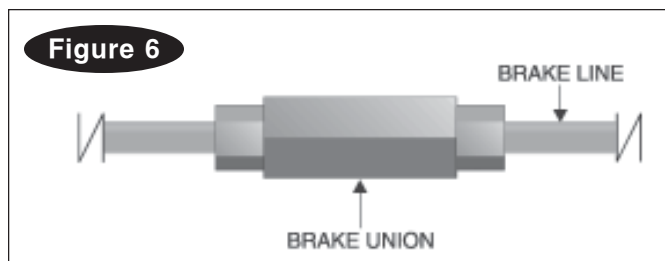

Figure 8

INSTALL THE PROPORTIONING VALVE

continued from preceding page

Since the brake tee will not thread onto the rubber brake hose (Figure 7), it will be necessary to attach a short section of steel brake line and install the brake tee as shown in Figure 8. This section of steel brake line is not supplied; contact an auto parts store.

CAUTION

If you are installing BrakeMaster in a Ford Class C motorhome, tee into the front hydraulic brake line. The rear hydraulic brake line does not supply sufficient hydraulic pressure to brake the towed vehicle properly.

2. Determine the best location to attach the proportioning valve bracket, based on the following:

A. There must be adequate room on the frame to mount the proportioning valve assembly (Figure 9) securely in place.

B. When the proportioning valve is installed, the bleeder valve (Figure 9) must point up and the exhaust port (Figure 9) must point down.

C. The proportioning valve and its attachments must not interfere with the movement or proper operation of any chassis components.

Also, there must be sufficient clearance to bolt the proportioning valve bracket to the frame without causing damage to any other component.

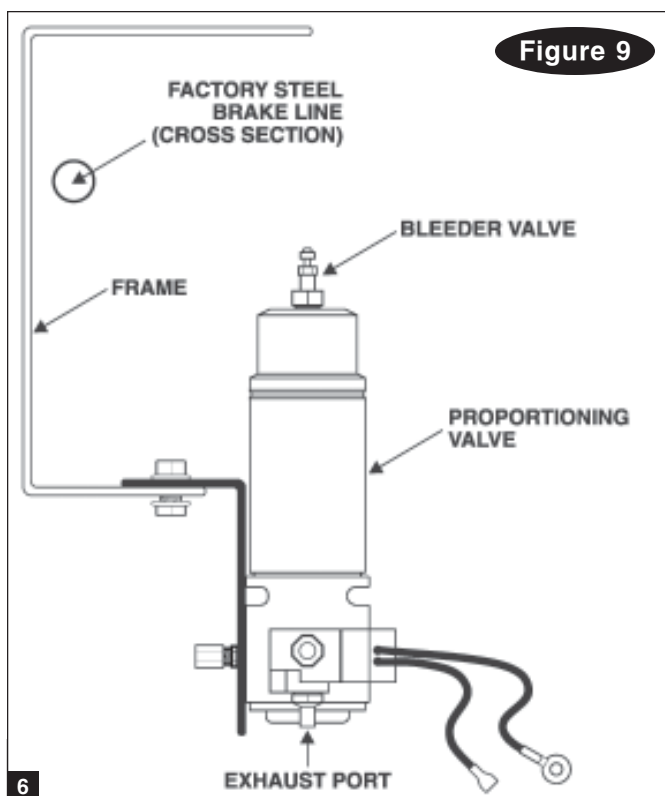

D. The proportioning valve assembly must be installed close enough to the motorhome's brake line to allow the included section of brake line to reach the brake union (or other point you have chosen to tee into the brake line).

E. The closer the proportioning valve is to the air compressor, the less air line will have to be routed between them later.

WARNING

The proportioning valve must be mounted with the bleeder valve pointing up. The valve will not bleed the brake system if it is not pointing up, which will cause brake failure.

Failure to follow these instructions may cause property damage, personal injury or even death.

3. Before attaching the proportioning valve, first remove any residual vacuum from the motorhome's brake power booster (if the motorhome is so equipped) – apply the motorhome brake several times, with the engine off.

4. Next, remove the master cylinder reservoir cover and (if necessary) fill the reservoir with brake fluid, up to the maximum marking. Reattach the cover.

WARNING

Wear appropriate eye protection when working on the brake system. If brake fluid comes into contact with your eyes, follow the manufacturer's instructions.

Failure to follow these instructions may cause severe eye injury.

WARNING

Never use old brake fluid to fill the master cylinder, or to replace lost brake fluid. Old brake fluid contains moisture and contaminants which may damage the braking system, or cause the brake fluid to boil under certain conditions.

Failure to follow these instructions may result in a complete loss of braking pressure, which may cause property damage, personal injury or even death.

5. Position a bucket or pan under the brake union (or other point you have chosen to tee into the brake line) to catch any brake fluid.

Clean any dirt or debris away from the brake union and use two open end or line wrenches to disconnect both ends of the brake line from the union. (It may be necessary to soak the connections with

continued on next page

INSTALL THE PROPORTIONING VALVE

continued from preceding page
penetrating oil to break them free.)

Do not bend the brake line, or damage the threads.

When the brake line is disconnected from the union, plug the line going toward the master cylinder to prevent any further loss of brake fluid.

CAUTION

Check the brake fluid level often after the brake line is disconnected, and while the proportioning valve is being installed. Add brake fluid as necessary to prevent the brake fluid level from falling low enough to allow air bubbles into the master cylinder. If air is allowed into the brake system from the master cylinder, all brakes, and any components connected to the hydraulic brake system, must be bled.

6. At the mounting location you have chosen, use the two pre-drilled holes in the proportioning valve bracket (Figure 10) as templates to mark and drill two 3/8" holes through the frame.

Use the two supplied 3/8" bolts and nuts to attach the proportioning valve to the frame, as shown in Figure 10.

7. Use a ring terminal to ground the solenoid valve (Figure 11) by connecting one of the black wires from the solenoid valve to any good chassis ground.

8. Determine the correct size of brake tee to use (both 1/4" and 3/16" tees are included) and then connect it to the two factory steel brake lines, as shown in Figure 11. (If the motorhome brake line has met-

ric fittings it will be necessary to use a metric-to-English converter – ROADMASTER part number 357180-00, M12 x 1 metric/standard T-fitting – to attach the proportioning valve. This part is not supplied in the kit; contact ROADMASTER.)

Note: if the brake tee is pointing up when the brake lines are connected, less brake fluid will be lost.

continued on next page

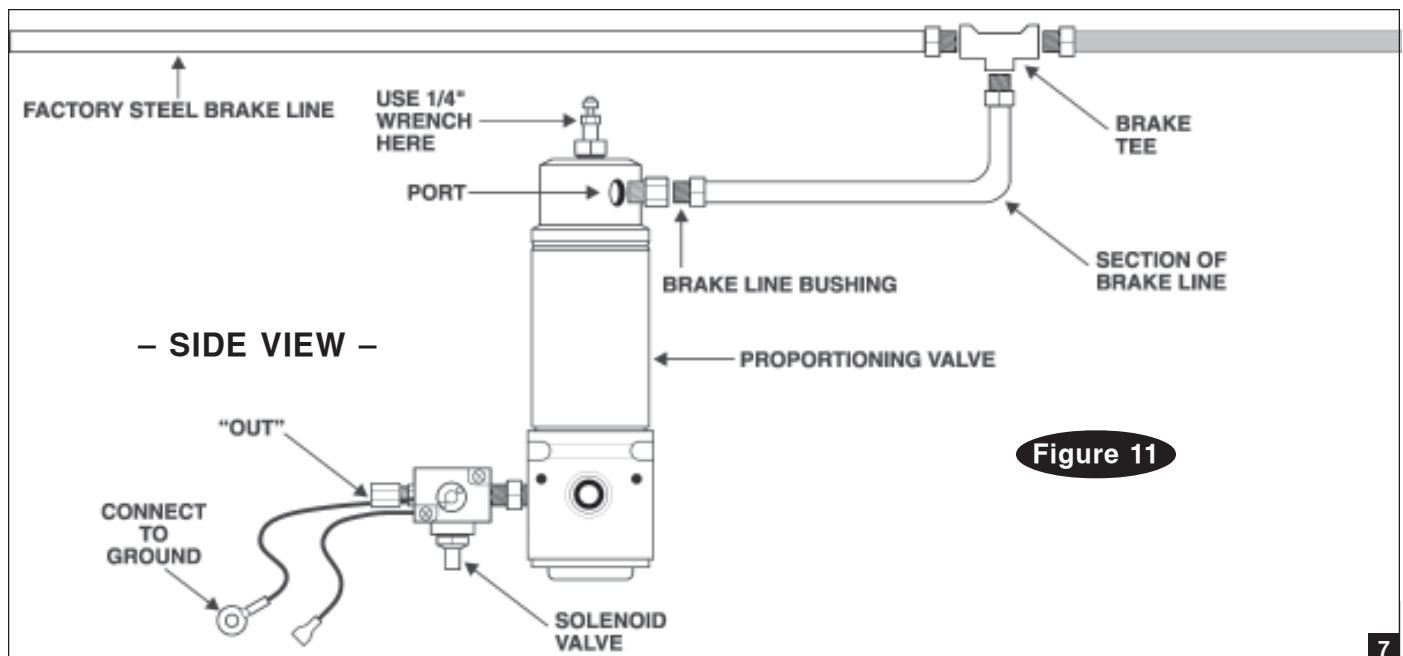
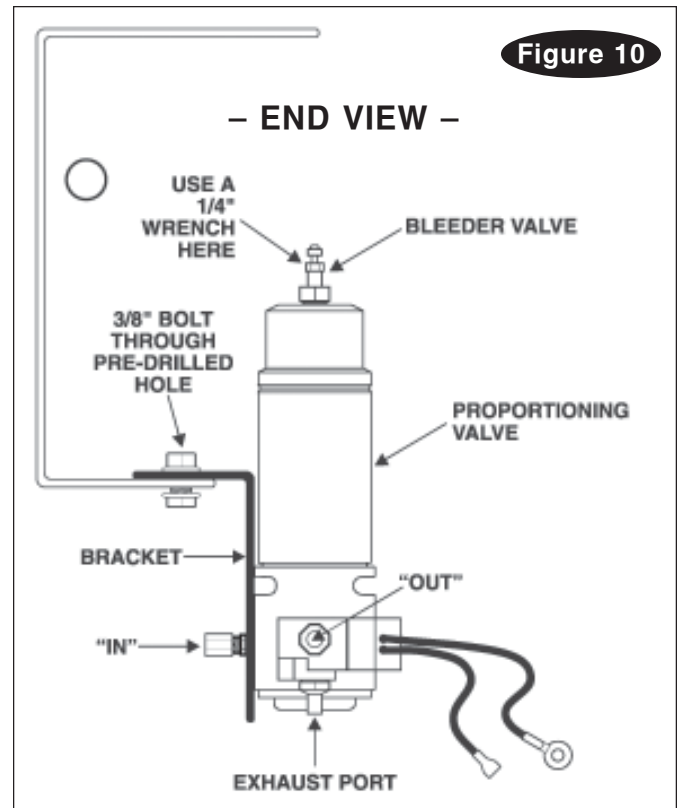

INSTALL THE PROPORTIONING VALVE

continued from preceding page

9. Next, connect the brake tee (Figure 11) to the port (Figure 11) on the proportioning valve, with one of the provided sections of brake line (Figure 11). Two sizes of brake line are provided for this purpose – 1/4" and 3/16".

A. If the motorhome has 1/4" brake lines – thread it into the fitting on the port on the proportioning valve.

B. If the motorhome has 3/16" brake lines – screw the flair adaptor (Figure 12) onto the fitting on the port on the proportioning valve. Then, attach the brake line to the flair adaptor, as shown in Figure 12.

Note: the port (Figure 11) can be rotated up to one full turn counterclockwise for easier connection to the section of brake line. Turn the nut on the port with a wrench until the blue cylinder can be rotated into position, then tighten the nut on the port to lock the blue cylinder.

10. Connect the section of brake line to the tee.

In most cases, it will be necessary to bend the section of brake line – use extreme care not to kink the brake line. If the brake line is kinked, it must be replaced with another section of brake line.

WARNING

If the section of brake line between the proportioning valve and brake tee is kinked, replace it with another section of brake line.

A kink in the brake line will cause brake failure, which may result in property damage, personal injury or even death.

11. The proportioning valve is now installed. However, the process of installing the valve has allowed air to enter the braking system. The air in the proportioning valve, as well as the air in the brake lines, must be bled before the motorhome is driven.

12. First, using a 1/4" wrench at the bleeder valve (Figure 10), bleed the air out of the proportioning valve. Do not loosen the 1/2" fitting.

After the air is bled from the proportioning valve, proceed to the next section – “Bleed the Brakes.”

WARNING

After the proportioning valve is installed, bleed the air from the valve (as described above), as well as the motorhome's brake system, before driving the motorhome.

Failure to bleed the brakes will cause a reduction in braking efficiency or a complete loss of brake pressure, which may result in property damage, personal injury or even death.

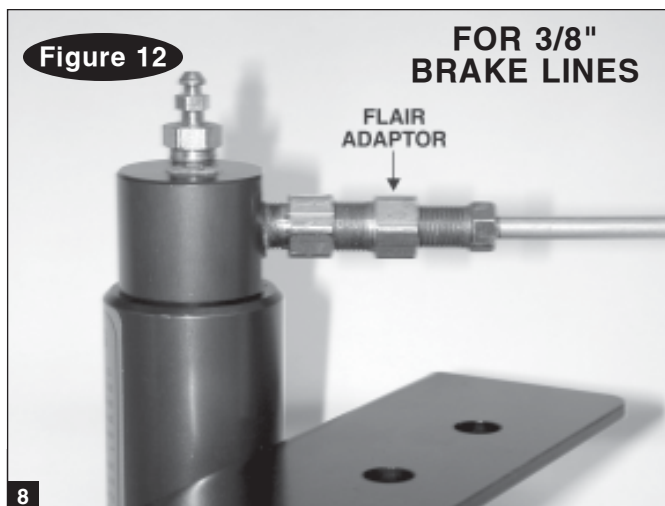

BLEED THE BRAKES

WARNING

After the proportioning valve is installed, bleed the air from the valve (as described in step 12 under “Install the proportioning valve”), as well as the motorhome’s brake system, before driving the motorhome.

Failure to bleed the brakes will cause a reduction in braking efficiency or a complete loss of brake pressure, which may result in property damage, personal injury or even death.

General information

You must bleed the brakes of every wheel that is downstream from the brake union you teed into when you installed the proportioning valve.

Instructions for bleeding all of the brake lines are included; however, it is not necessary to bleed the brakes upstream from the brake union, unless air was allowed into the master cylinder by not replenishing lost brake fluid.

CAUTION

Check the brake fluid level often while bleeding the brakes. Add brake fluid as necessary to prevent the brake fluid level from falling low enough to allow air bubbles into the master cylinder. If air is allowed into the brake system from the master cylinder, all brakes, and all components connected to the hydraulic brake system, must be bled.

WARNING

Never use old brake fluid to fill the master cylinder, or to replace lost brake fluid. Old brake fluid contains moisture and contaminants which may damage the braking system, or cause the brake fluid to boil under certain conditions.

Failure to follow these instructions may result in a complete loss of braking pressure, which may cause property damage, personal injury or even death.

WARNING

Wear appropriate eye protection when working on the brake system. If brake fluid comes into contact with your eyes, follow the manufacturer’s instructions.

Failure to follow these instructions may cause severe eye injury.

For ABS (anti-lock braking systems)...

The front of an ABS system can be bled in the same manner as the traditional method described below. However, the rear brakes must be bled with a pressurized bleeder system, or, the hydraulic accumulator must be fully charged.

The hydraulic accumulator can be charged by starting the engine.

Traditional method

This method requires:

- an assistant (to pump the brake pedal)
- a box-end wrench suitable for the vehicle’s bleeder screws. (An offset wrench allows the most movement.)
- a supply of brake fluid
- a disposable container
- a length of clear plastic tubing to fit over the bleeder screws. (The tubing must have an inner diameter which will allow it to seal over the bleeder screws.)

1. First, remove the master cylinder reservoir cover and fill the reservoir with brake fluid (if necessary) up to the maximum marking. Reattach the cover.

Check the brake fluid level frequently while bleeding the brakes.

2. If bleeding all brake lines, the sequence is determined by the location of the lines in relation to the master cylinder – in general, always bleed the brake line farthest from the master cylinder first, then the other brake line in the same half of the circuit just bled:

If you know that the brake system is split front to rear, as is the case with many rear wheel drive vehicles, the sequence is as follows:

1. right rear
2. left rear
3. right front
4. left front

If you know that the brake system is split diagonally, as is the case with many smaller front wheel drive vehicles, the sequence is as follows:

1. right rear
2. left front
3. left rear
4. right front

3. Loosen the bleeder screw at the first wheel cyl-

continued on next page

BLEED THE BRAKES

Traditional method

continued from preceding page

inder. Remove the rubber cap (if present).

4. Position the box-end wrench over the bleeder screw.

5. Place one end of the clear plastic tubing over the nipple of the bleeder screw, and place the other end of the tubing into the disposable container.

6. Instruct the assistant to “apply.” The assistant should pump the brake pedal three times, then hold the pedal down firmly, and respond with “applied.”

7. Loosen the bleeder screw with a brief quarter turn, just enough to allow a solid stream of brake fluid to flow through the tubing. (The brake pedal will “fall” to the floorboard as the bleeder screw is opened. Instruct the assistant in advance not to release the brakes until instructed.)

8. Close the bleeder screw by tightening it gently.

9. Instruct the assistant to “release” the brakes.

Note: do not release the brake pedal while the bleeder screw is open – air will be pulled into the system.

The assistant should respond with “released.”

10. Inspect the fluid in the disposable container for air bubbles.

11. Continue to bleed the brake fluid until air bubbles are no longer present.

12. Replace the rubber cap you removed earlier (if one was present).

13. Move on to the next wheel cylinder and repeat the process described above, until all of the brake lines have been bled.

Check the brake fluid level in the master cylinder reservoir after bleeding each wheel. Add fluid, as necessary, to keep the level at the maximum marking.

When all of the brake lines have been bled, check and refill the master cylinder reservoir, if necessary.

14. Inspect the bleeder screws and other fittings for leaks. Correct, if necessary. Inspect the proportioning valve and the brake line fittings at the six points indicated in Figure 13 and correct, if necessary.

15. Depress and release the brake pedal several times – it should feel firm and solid when it is depressed.

If the brake pedal does not provide firm resistance, there is air in one or more of the brake lines. Bleed the brake lines again, as described above.

⚠ WARNING

If the brake pedal does not provide firm resistance after the brakes have been bled, bleed the brake lines again. Do not drive the motorhome until the brake pedal provides firm resistance when it is depressed.

The brakes will not function at full capacity, or may not function at all, with air in the lines. Insufficient brake pressure may result in property damage, personal injury or even death.

One-person methods

There are a number of commercially-available products which allow one person to bleed the brake lines. They use two general methods – vacuum bleeding and pressurized bleeding.

Vacuum bleeding systems use a vacuum to draw the air out of the brake system, eliminating the need for an assistant. Typically, a tube runs from the bleeder valve to a sealed container. Another tube runs from the container to a hand-held pump.

When the bleeder valve is opened, the pump draws the brake fluid and air bubbles out of the brake line and into the container.

If you use this method, follow the same sequence as described in the traditional method.

Pressurized bleeding systems are used by many professional mechanics. These systems attach to the top of the master cylinder reservoir and pressurize the hydraulic fluid in the brake lines, eliminating the need for an assistant.

If you use this method, follow the same sequence and procedures as described in the traditional method.

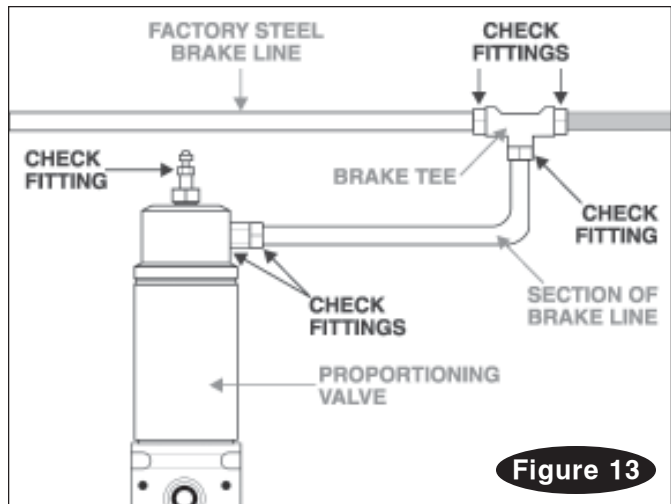

Figure 13

WIRE THE PROPORTIONING VALVE

The solenoid valve (Figure 11) on the proportioning valve allows air to pass into the BrakeMaster system each time the motorhome's brake pedal is depressed. The solenoid valve will allow air to pass only when it receives an electrical signal from the motorhome brake light system.

Where you connect the solenoid valve to the motorhome depends upon the type of brake light system in the motorhome. Compare the motorhome's brake and turn lights to Figures 14 and 15.

1. If the motorhome has a separate brake and turn signal system (Figure 14), connect the remaining black wire extending from the solenoid valve to the motorhome's brake light wire. The brake light wire can usually be located in the wiring harness that runs along the frame; the connection can be made at any convenient point.

Refer to the inside front cover for a wiring schematic.

2. If the motorhome has a combined brake and turn signal system (Figure 15), attach the included butt connector to the end of the remaining wire extending from the solenoid valve, and attach the length of included wire to the other end of the butt connector.

Route the wire from the solenoid valve to the brake light wire, under the dashboard of the motorhome. With a test light, find the "cold" side of the brake light switch – the "cold" side of the switch does not register voltage unless the brakes are applied.

Cut the brake light wire, a few inches downstream from the "cold" side of the brake light switch. Cut the wire from the solenoid valve to length, then attach it to the brake light wire with another butt connector.

Refer to the inside front cover for a wiring schematic.

Ensure that the wire will not present an obstacle or hazard to the motorhome driver, or interfere with the operation of the vehicle. Use one or more of the included wire ties, if necessary, to secure the wire out of the way.

Note: connect the wire from the solenoid valve to the brake light wire before the turn signal switch (located in the steering column). If the wire is connected after the turn signal switch, BrakeMaster will not function properly.

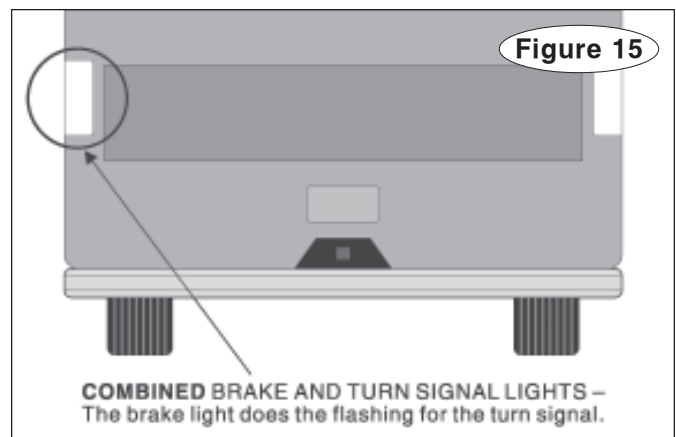
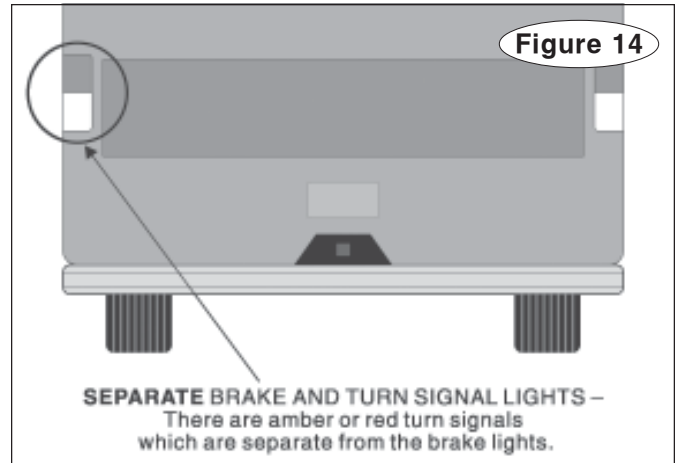

INSTALL THE AIR LINES

1. Find a suitable location at the rear of the motorhome, near the center, to attach the preassembled female quick coupler (with an orange shield base – Figure 16). Attach the bracket with two of the supplied ¼" nuts and bolts, with the female quick coupler pointing away from the motorhome.

Note: the weather covers will prevent dirt or debris from entering the lines. Keep the fittings covered when the braking system is not in use.

2. Route the provided length of air line from the "in" compression fitting on the air compressor (Figure 1) to the "in" compression fitting on the proportioning valve (Figure 10).

Tape the ends of the air line and avoid moving parts, sharp edges or "hot" components such as the engine or the exhaust system. Do not kink the air line, or bend it to the extent that it crimps or creases.

CAUTION

Do not position the air line closer than two feet from any heat source. The heat will soften the plastic, which will cause the air line to rupture.

If the air line is ruptured, the supplemental braking system will not function.

Do not kink the air line, or bend it to the extent that it crimps or creases – air pressure will be substantially reduced, or blocked entirely, at the kink in the line.

If the air pressure is reduced, the supplemental braking system will not function, or may only function intermittently.

Where appropriate, use one or more of the included wire ties to secure the air line in place.

3. Trim the air line to length and connect it to the "in" compression fitting on the air compressor, and to the "in" compression fitting on the proportioning valve – first, if necessary, trim each end of the air line, to make a smooth and straight cut. Then slide the compression nut and the ferrule (Figure 16) over the air line. Position the ferrule ¼" from the end of

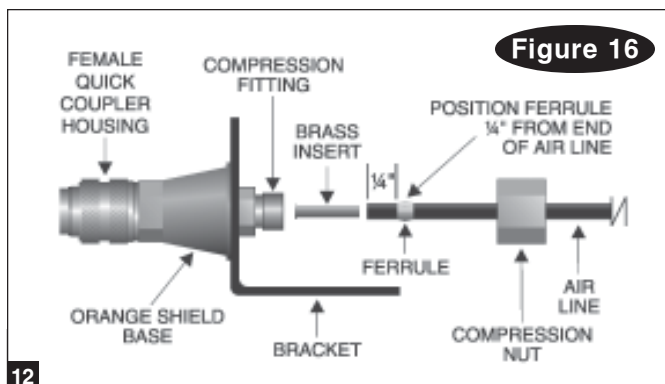

the air line. Next, slide one of the brass inserts (Figure 16) into the end of the line.

Note: if the brass inserts are omitted, the fittings will not be airtight.

Now, push the air line into the compression fitting, as far as it can go. Then push the ferrule into the compression fitting, and tighten the compression nut onto the fitting.

Note: if the compression nut is overtightened, the fitting will not be airtight. After completing the installation, check all the fittings for air leaks – see "Final connections and system test."

Note: if the air line is connected to the "out" compression fitting on the proportioning valve, no air can pass through the valve, and the BrakeMaster system will not function.

4. With the air lines attached, position the air compressor over the four pilot holes you drilled earlier, and use the provided screws to secure the compressor in place.

5. Next, route the remaining length of air line from the "out" compression fitting on the proportioning valve (Figure 11) to the female quick coupler you attached in step 1 (above).

As described above, tape the ends of the air line and avoid damaging the line as you route it.

Trim the air line to length and connect it to both compression fittings. Use the same method described in step 3 (above).

6. Check to make certain that the handle on the air tank drain valve (Figure 17) is closed.

CAUTION

The handle on the air tank drain valve should only be opened to drain the air tank. If the handle is open during towing, the air compressor will run constantly, which may damage the compressor.

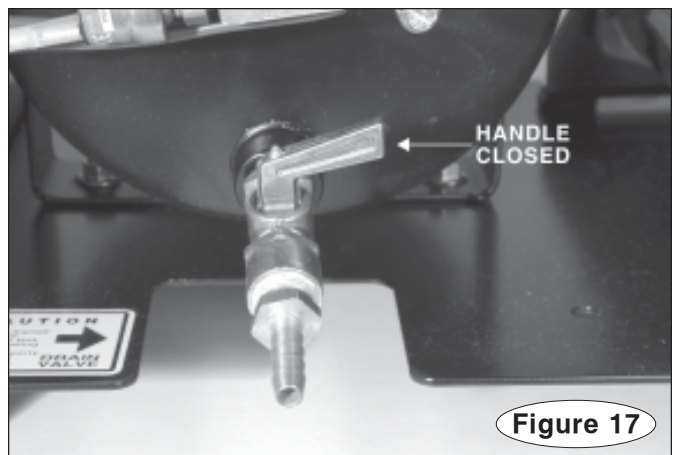

INSTALL THE MOTORHOME MONITOR SYSTEM

Step One

Wire the motorhome

Note: Some motorhomes are manufactured with auxiliary wires pre-strung from the rear of the motorhome to the dashboard, for aftermarket accessories such as this. Call the manufacturer.

1. Attach the end of the black wire with the female bullet connector to the back of the motorhome, near the female quick coupler you attached in step 1, "Install air lines in the motorhome."

Attach the connector with one or more of the included wire ties. Allow enough slack so that a male bullet connector can be plugged into and out of it.

2. Once the female bullet connector is attached, route the wire from the back of the motorhome to the underside of the dashboard. Avoid lines, hoses, moving parts (slideouts, sliding generators, sliding battery trays) or "hot" components such as exhaust systems. Where appropriate, use wire ties to secure the wire to the undercarriage.

Step Two

Attach the LED

1. Chose an area on the motorhome dashboard to mount the LED. Look for a mounting point away from pre-existing wires or components, where the LED can be easily seen by the driver.

2. Drill a 5/16-inch hole through the dashboard at the point you have chosen. Before drilling, make certain you will not damage any components on the other side.

3. Center the LED decal (Figure 18) over the hole, and press it down. Or, you may chose to omit the decal, depending on your preferences.

4. From the top of the dashboard, slide the LED through the hole, wires first, until the base of the bulb (Figure 18) is flush to the top of the dash.

5. From the underside of the dash, fit both of the wires through the speed nut (Figure 18). Then push the speed nut up, against the dash, to secure the LED in place.

6. Connect to power – Trim the black wire, which you routed from the back of the motorhome. (Save the excess; you may use it in the next step.) Then, connect the black wire to the red LED wire, using one of the included butt connectors.

7. Connect to ground – Connect the ground wire from the LED to any good chassis ground, using the included ring terminal. (If necessary, use any excess wire from the preceding step to extend the length of the ground wire.)

Step Three

Connect the patch cord between the motorhome and the towed vehicle

Note: The patch cord is the six-foot length of air line and wiring, covered in blue plastic loom.

1. Connect the male and female quick couplers at either end of the air line to the corresponding quick couplers on the motorhome and towed vehicle.

Push the couplers together until the housing (Figure 16) on the female coupler slides forward and 'clicks,' locking the couplers together.

(To disconnect the couplers, pull back on the housing on the female coupler until the couplers release.)

CAUTION

Never pull back on the housing to connect the couplers – this will prevent the couplers from locking. The couplers may disconnect during towing, preventing the supplemental braking system from functioning.

2. Connect the male bullet connectors at either end of the monitor wire to the female bullet connectors on the motorhome and towed vehicle monitor wiring harnesses.

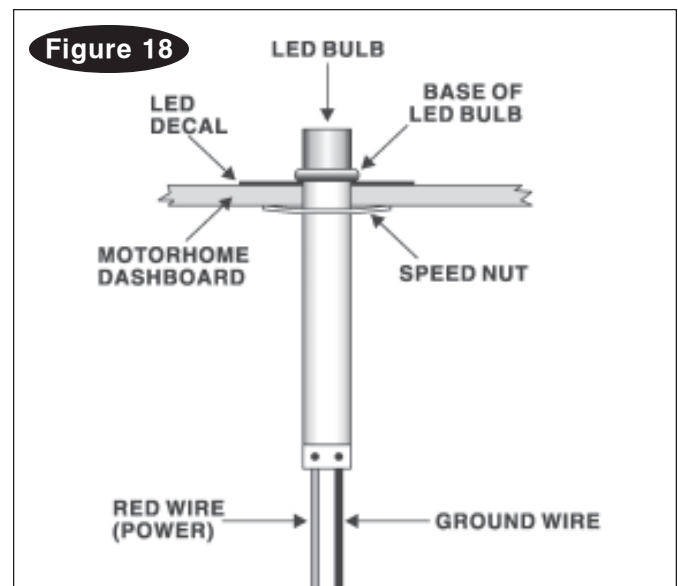

FINAL CONNECTIONS AND SYSTEM TEST

Step One

Connect the air compressor to power

1. Now that all components are installed, connect the air compressor to power – connect the 12-gauge red wire (positive terminal) and black wire (negative terminal) which you routed from the air compressor to the motorhome's starting battery. (Refer to steps 5 and 6 under "Wire the air compressor.")

2. Attach the 14-gauge blue wire which you routed from the air compressor to the fuse you selected in step 10 under "Wire the air compressor" – crimp the wire onto the fuse tap, using the included spade connector.

Step Two

Test the system

CAUTION

Always deplete the stored vacuum in the towed vehicle's power brake system before towing – pump the brake pedal several times.

Depending on the make and model of the towed vehicle, it may be necessary to pump the brake pedal repeatedly to deplete the vacuum.

If the vacuum is not released, the supplemental braking system will apply excessive braking force when it is activated, which will cause severe tire and/or brake system damage to the towed vehicle.

1. The motorhome and towed vehicle must be stationary for the system test, and ready for towing.

A. All components of the braking system must be properly connected –

- Connect and attach the tow bar to both vehicles, and shift the towed vehicle's transmission into the proper gear for towing (according to the manufacturers' instructions).

CAUTION

To prevent the towed vehicle from rolling, connect and attach the tow bar to both vehicles before shifting the towed vehicle's transmission into the proper gear for towing.

- Connect the patch cord between the two vehicles – both the air line quick couplers and the motorhome monitor bullet connectors.

- Attach the air cylinder to the brake pedal and mounting post (or seat bracket adaptor) – see "Install the air cylinder anchor plate" in the complete BrakeMaster installation instructions.

(For the most recent copy of the instructions, visit www.roadmasterinc.com. Select 'Tech Support,' 'Installation Instructions and Miscellaneous Documents,' and 'BrakeMaster 9000' under 'Braking Systems.')

Connect the male quick coupler at the end of the air line on the air cylinder to the female quick coupler at the end of the air line mounted in the passenger compartment.

- Clip one end of the steel break away cable to the break away pin; clip the other end of the cable to the rear of the motorhome, close to the center.

B. Turn the motorhome engine on, and leave it running. Turn the towed vehicle's ignition key to the "tow" position.

2. Check for leaks in the air system: start the motorhome and allow the air compressor to run until it shuts off. Then, apply the motorhome brakes and hold the brake pedal down, until the air compressor shuts off again (approximately 45 seconds).

Cover each joint, fitting and connection in the air system (including the proportioning valve – Figure 13) with a leak check solution.

Tighten any fittings, if necessary, and repeat until all connections are airtight.

CAUTION

The air system now contains pressurized air, which may cause severe eye or ear injury if it is inadvertently released. Wear appropriate eye and ear protection before adjusting the air system connections and fittings.

3. Confirm the proper operation of the braking system: depress and hold the motorhome brake pedal down. At the towed vehicle, the air cylinder shaft and pedal clamp will extend. Then, release the brake pedal. The air cylinder shaft and pedal clamp will retract.

4. Confirm that the motorhome monitor is functioning: the LED will illuminate after the motorhome brake pedal is depressed, and stop illuminating when the brake pedal is released.

WARNING

If the LED does not illuminate, as described above, identify and correct the cause of the mal-

continued on next page

FINAL CONNECTIONS AND SYSTEM TEST

Test the system

continued from preceding page

function before using the supplemental braking system. Refer to the Troubleshooting section for possible causes.

The LED is the only indication of braking activity at the motorhome. Severe damage to the towed vehicle, a loss of vehicular control, or other consequential, non-warranty damage can occur if the driver of the motorhome is unaware that the supplemental braking system is not functioning properly.

Failure to follow these instructions may cause property damage, personal injury or even death.

5. Confirm the proper operation of the break away system –

Note: The break away system is included with the BrakeMaster 9060; it is an optional accessory with the BrakeMaster 9000.

Charge the break away air reservoir – start the motorhome and allow the air compressor to run until it shuts off. Then, apply the motorhome brakes and hold the brake pedal down, until the air compressor shuts off again (approximately 45 seconds).

WARNING

The break away air reservoir must be charged, as described above, every time the motorhome and towed vehicle are connected. If the air reservoir is not charged, the break away system will not apply braking pressure if the towed vehicle separates from the motorhome, which may cause property damage, personal injury or even death.

Next, remove the break away pin at the front of the break away switch. The air cylinder and pedal clamp will extend, confirming the proper operation of the break away system.

To retract the air cylinder and pedal clamp, briefly disconnect the quick couplers from the air line extending from the air cylinder. Then, reconnect the break away pin.

Before towing, charge the break away air reservoir, as described above.

6. Confirm the proper operation of the towed vehicle's brake lights and turn signals –

A. Depress the motorhome brake pedal; confirm that the towed vehicle's brake lights illuminate. Activate both motorhome turn signals; confirm that the towed vehicle's turn signals activate.

If the towed vehicle's brake lights and turn signals do not operate in tandem with the motorhome,

you must install a non-intrusive lighting system or re-wire the towed vehicle. See "Brake light solutions" in the complete BrakeMaster installation instructions.

(For the most recent copy of the instructions, visit www.roadmasterinc.com. Select 'Tech Support,' 'Installation Instructions and Miscellaneous Documents,' and 'BrakeMaster 9000' under 'Braking Systems.')

B. With one of the motorhome turn signals activated, depress the motorhome brake pedal. Confirm that the towed vehicle's brake lights and turn signal both illuminate.

If the towed vehicle's brake lights override the turn signal, you must install a non-intrusive lighting system or re-wire the towed vehicle. See "Brake light solutions" in the complete BrakeMaster installation instructions.

WARNING

By law, a towed vehicle's turn signals and brake lights must operate in tandem with the motorhome's, as described above. If they do not, drivers behind the towed vehicle will not be alerted when the motorhome stops or turns, which may cause an accident.

If the towed vehicle's brake lights and turn signals do not operate in tandem with the motorhome, either install a non-intrusive lighting system or re-wire the towed vehicle according to the instructions under "Brake light solutions" in the complete BrakeMaster instructions. Then test for proper operation, as described in step 6, above.

(For the most recent copy of the instructions, visit www.roadmasterinc.com. Select 'Tech Support,' 'Installation Instructions and Miscellaneous Documents,' and 'BrakeMaster 9000' under 'Braking Systems.')

Failure to follow these instructions may cause property damage, personal injury or even death.

TROUBLESHOOTING

Note: to identify components in the towed vehicle described below, refer to the complete BrakeMaster installation instructions. For the most recent copy of the instructions, visit www.roadmasterinc.com. Select 'Tech Support,' 'Installation Instructions and Miscellaneous Documents,' and 'BrakeMaster 9000' under 'Braking Systems.'

Symptom

The motorhome monitor LED does not illuminate, even though the brakes in the towed vehicle are being applied.

Solution

1. The monitor LED will not illuminate during very light braking.
2. Make certain that the monitor patch cord is securely connected between the two vehicles.
3. The towed vehicle-to-motorhome electrical cord must also be connected – the monitor system uses it for the ground wire.
4. The monitor LED is connected to the towed vehicle's brake light circuit. If the fuse in the circuit is blown, the LED will not illuminate. Check the towed vehicle's brake lights – if they illuminate when the brake pedal is depressed, the fuse is good.
5. Is the optional Brake-Lite Relay installed in the towed vehicle? If so, make certain that the monitor wire is connected to the towed vehicle's brake light wire **after** the brake light switch, but **before** the Brake-Lite Relay – connecting the wire anywhere else will prevent the monitor LED from functioning.

Symptom

Nothing happens after proper installation.

Solution

1. The motorhome engine must be running – if the engine is off, there may be insufficient hydraulic pressure to activate BrakeMaster.
2. Check the air line connections. Remove the weather covers from the quick couplers at both vehicles, and gently tug on the air line to verify that the quick couplers are connected.
Check to make certain that the air cylinder quick coupler is connected to the air line in the passenger compartment.
3. Check the wiring at the solenoid valve (on the proportioning valve). One of the black wires must be connected to a good chassis ground (Figure 11). The other black wire must be connected to the motorhome brake wire downstream from the brake light switch (Refer to "Wire the proportioning valve."). Use a test light to confirm that the solenoid valve is receiving power when the motorhome brake pedal is depressed.

If the connections are good, test for proper func-

tion – with the motorhome engine running, have an assistant depress the motorhome brake pedal while you listen for a "click" at the solenoid valve. The solenoid valve should "click" every time the brake pedal is depressed.

4. Disconnect the air line from the "out" compression fitting on the solenoid valve (Figure 11). Have an assistant depress the motorhome brake pedal – the proportioning valve should release air each time the pedal is depressed.

A. If there is air at the proportioning valve – follow the air line back to the air cylinder in the towed vehicle. Inspect the entire line for deformities caused by excessive heat, and/or kinks in the line, which would restrict the air flow – replace the entire section of air line if any are found.

Disconnect the quick couplers to confirm that they are allowing air to flow through them.

B. If there is no air at the proportioning valve – check to confirm that the air line between the air compressor and the proportioning valve is connected to the correct fitting. It should run from the "in" fitting on the air compressor (Figure 1) to the "in" fitting on the proportioning valve (Figure 10).

If the air line is connected to the "out" fitting on the proportioning valve, no air can pass through the valve, and the BrakeMaster system will not function.

If this is the case, reconnect the line from the air compressor to the "in" fitting in the proportioning valve.

Symptom

The compressor runs constantly, or runs much more frequently than I think it should.

Solution

1. Check for leaks in the air system.
2. Make certain that the drain valve on the air compressor air tank is closed. Refer to Figure 17.
3. If a BrakeAway system is installed on the towed vehicle, make certain that the drain valve on the BreakAway air reservoir is closed.
4. Make certain that a female quick coupler has been installed at the rear of the motorhome – a male quick coupler does not have a check valve to prevent air from escaping.

Symptom

It seems to require a significant amount of brake pressure in the motorhome before the BrakeMaster air cylinder activates in the towed vehicle.

Solution

1. The motorhome engine must be running – if the engine is off, there may be insufficient hydraulic pressure to activate BrakeMaster.
2. Inspect the air lines for deformities caused by excessive heat, and/or kinks in the line, which would restrict the air flow – replace the entire section of air line

continued on next page

TROUBLESHOOTING

continued from preceding page

if any are found.

3. Check for leaks in the air system: after starting the motorhome, allow the air system to fully charge. Depress and hold the motorhome brake pedal down.

Cover each joint, fitting and connection in the air system with a leak check solution.

Tighten any fittings, if necessary, and repeat until all connections are airtight.

4. If the towing vehicle is a Ford Class C motorhome, the proportioning valve must be teed into the front hydraulic brake line – the rear brake line does not supply sufficient hydraulic pressure.

5. Not all of the air was bled from the brakes after installing the proportioning valve. Re-bleed the proportioning valve, as well as all brakes (and any components connected to the braking system) downstream from the brake tee.

Symptom

The BrakeMaster air cylinder will extend and depress the towed vehicle's brake pedal. However, it will not retract when the motorhome brake pedal is released.

Solution

1. Make certain that the air cylinder has been installed directly in line with the brake pedal. If it is mounted at an angle to the brake pedal (to one side or the other), the air cylinder may jam in the extended position.

2. Dirt or debris can enter the air lines if the weather covers are not used over the quick couplers. It may accumulate at the quick exhaust valve on the air cylinder, preventing the valve from venting air out of the air cylinder. Disassemble the quick exhaust valve and make certain it is not jammed.

3. If a system of diodes was used to wire the towed vehicle's lights for towing, make certain that a diode is installed at every point where the motorhome brake light wire connects to the towed vehicle's brake light wire.

When the air cylinder extends and depresses the towed vehicle's brake pedal, it energizes the towed vehicle's brake light wire. If diodes are not installed in the circuit, current will travel back to the motorhome and activate the BrakeMaster solenoid.

As long as the solenoid is activated, it will not allow air to vent from the air cylinder – the air cylinder will remain extended.

Symptom

The towed vehicle brakes abruptly the first time BrakeMaster is activated, 'flat spotting' the tires. Also, after towing, there may be excessive brake dust on the wheels of the towed vehicle, and/or an unusual odor near the towed vehicle's brakes.

Solution

1. The stored vacuum in the towed vehicle's power brake system **must** be depleted before towing – pump the brake pedal several times. Depending on the make and model of the towed vehicle, it may be necessary to pump the brake pedal repeatedly.

Deplete the vacuum in the power brakes every time the towed vehicle's engine has been started – typically, when the vehicle is connected for towing.

The engines in some vehicles, such as the Saturn Vue, must be started periodically during towing. If the towed vehicle's engine must be started periodically, always deplete the vacuum in the vehicle's power brake system **before** you resume towing.

Refer to the caution statement on page 14.

2. If the towed vehicle has an 'active' (or, 'continuous power assist') braking system, order the optional brake pressure reducer (part number 900002) to adapt the vehicle to the BrakeMaster system.

Vehicles with 'active' brake systems include several hybrid vehicles, such as the Ford Escape hybrid and the Mercury Mariner hybrid, as well as the H3 Hummer. These vehicles, and others with 'active' braking systems, are designed so that even when the ignition is turned to the 'tow' position, the braking system is still active.

If the reducer is not installed, BrakeMaster will apply excessive force to the towed vehicle's brake pedal.

3. If the towed vehicle does not have power brakes, order the optional brake pressure reducer (part number 900002) to adapt the vehicle to the BrakeMaster system.

BrakeMaster is designed to work with vehicles that have a power brake system (even though the power brakes are not activated while towing).

If the reducer is not installed, BrakeMaster will apply excessive force to the towed vehicle's brake pedal.

“We get your towed car there,
while **stopping safely** along the way.”

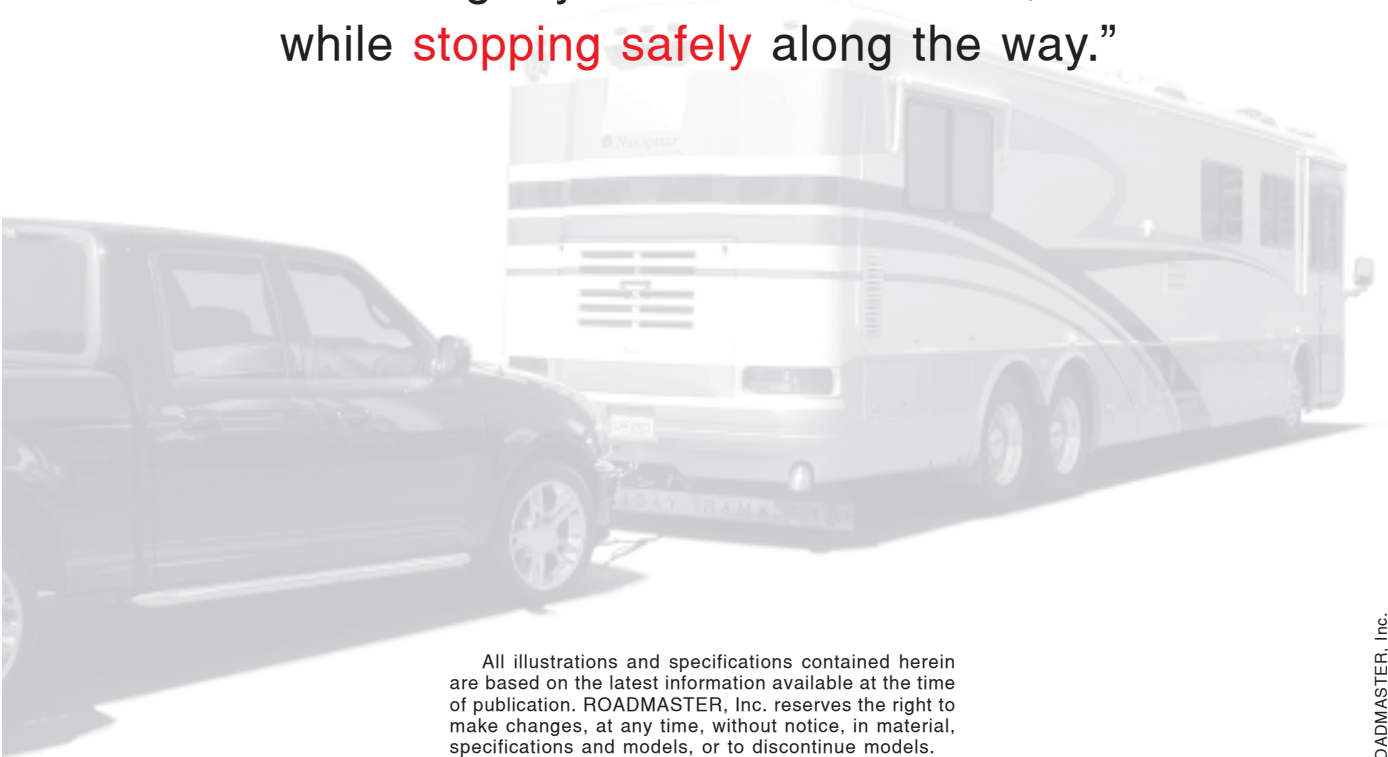

All illustrations and specifications contained herein are based on the latest information available at the time of publication. ROADMASTER, Inc. reserves the right to make changes, at any time, without notice, in material, specifications and models, or to discontinue models.



Quality Towing Systems since 1974
ROADMASTER, Inc. • 5602 N.E. Skyport Way • Portland, OR 97218
800-669-9690 • Fax 503-288-8900 • roadmasterinc.com