

ecoHITCH -Designed Specifically For Your **Green Vehicle**

Installation Instructions

Application Fits

2015 Volkswagen Golf TDI/GTI
X7309 & X7310

2" & 1.25" EcoHitch Stealth

200 lb. Tongue Weight/ 2,000 lb. Towing Weight

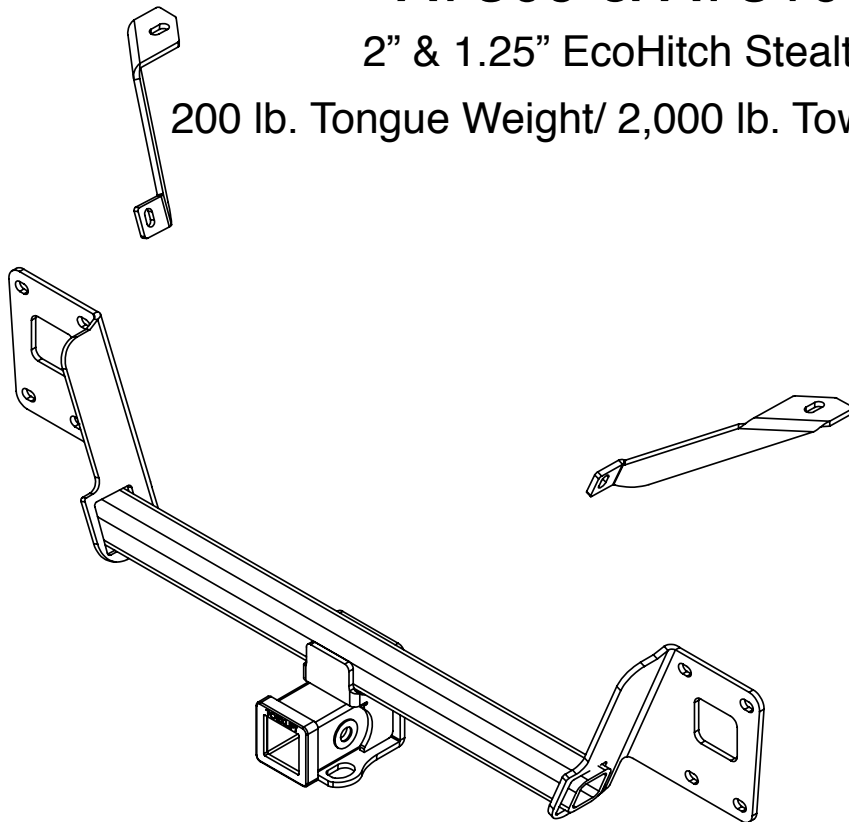

Torklift Central
315 Central Ave N
Kent, WA 98032
253-854-1832
www.torkliftcentral.com
support@tlcentral.com

Stay Connected



torkliftcentral



torkliftcentral



tlcentral



torklift central



torklift central



Bolt Kit Weight: 601g +/-

Hardware Included

QTY Fastener

QTY Fastener

- 7 5/16" USS Flat Washer
- 7 5/16" Lock Washer
- 2 3/8" SAE Flat Washer
- 2 3/8"-16 Serrated Flange Nut
- 2 3/8"-16x1" Gr.5 Hex Cap Screw
- 2 1/2" USS Flat Washer
- 2 1/2" Lock Washer

- 2 1/2"-13 Gr.5 Hex Nut
- 2 1/2"-13x2" Gr.5 Carriage Bolt
- 2 1/2"SQx2"x3.5" Plate Washer
- 1 1/2" Bolt Fisher
- 7 M8-1.25x40mm Hex Cap Screw
- 2 Support Strap
- 1 10" Trim-Lok

READ THESE INSTRUCTIONS THOROUGHLY AND ACCOUNT FOR ALL HARDWARE LISTED BEFORE BEGINNING INSTALLATION!

Step 1. Raise vehicle on suitable jack stands, ramps, or hoist.

Step 2. Remove the (8) lag screws along the underside of the bumper.
See Figure [1],[2],& [3].

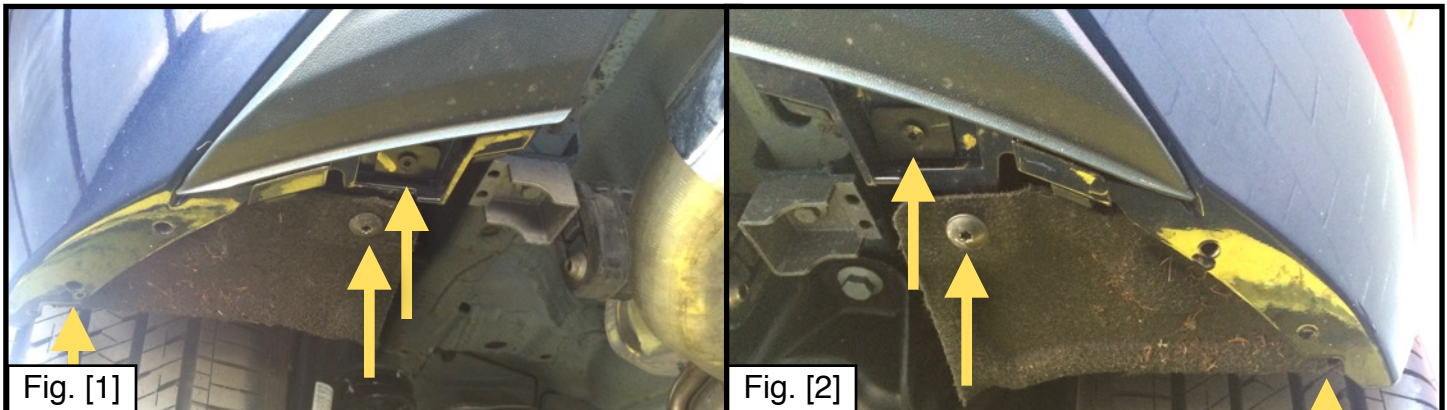

Step 3. Remove (3) lag screws from each of the rear wheel wells. Peel back the wheel well liner near the top of the well where the bumper meets the side body panels. Here you will find (1) screw on the driver and passenger sides to remove. See Figure [4], [5], & [6].

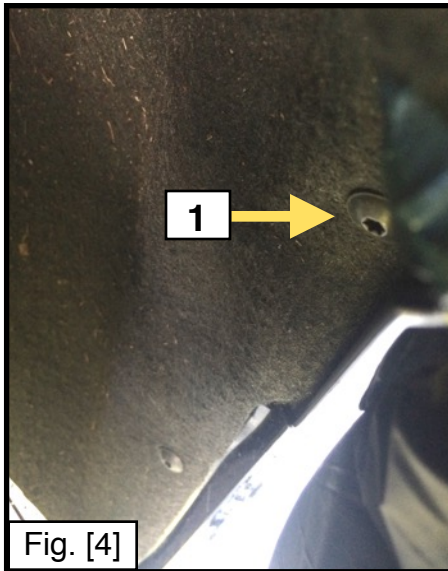

Fig. [4]



Fig. [5]

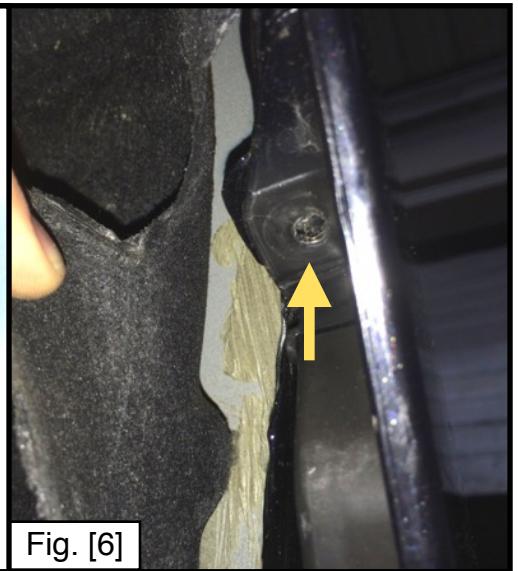

Fig. [6]

Step 4. Open the lift gate and open the tail light assembly access panels on the driver and passenger side. Unscrew the T.L.A. Securing Pin. Gently slide the T.L.A. rearward and disconnect the wire harness from the T.L.A. See Figure [7],[8],[9],[10],&[11].

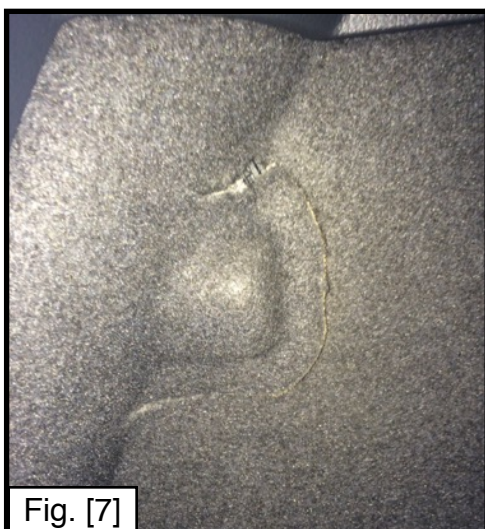

Fig. [7]



Fig. [8]

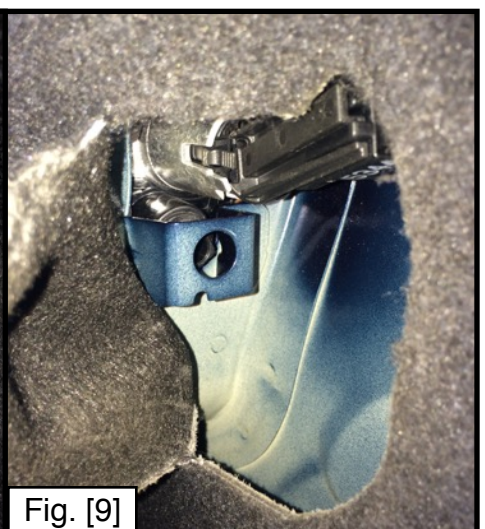

Fig. [9]

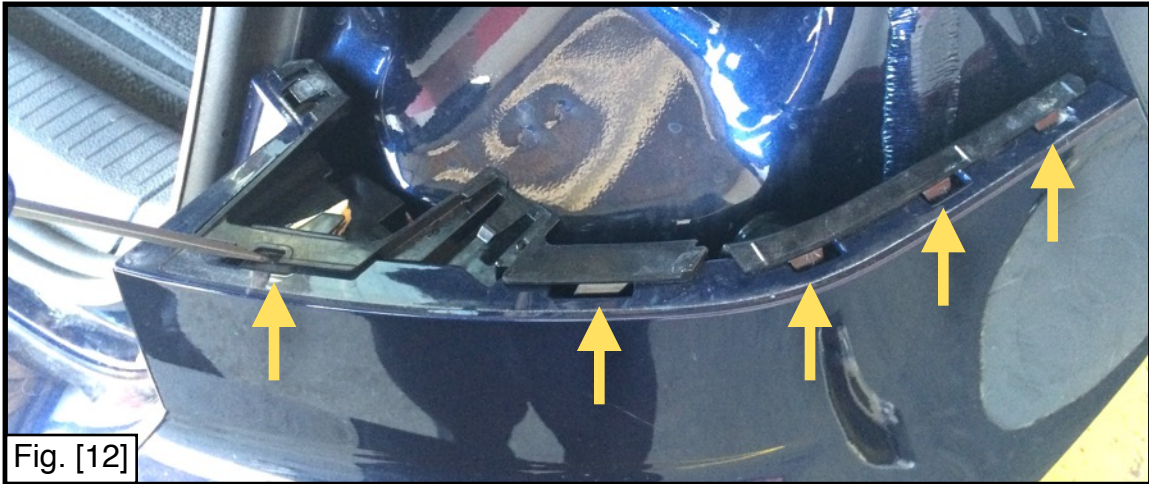

Fig. [10]

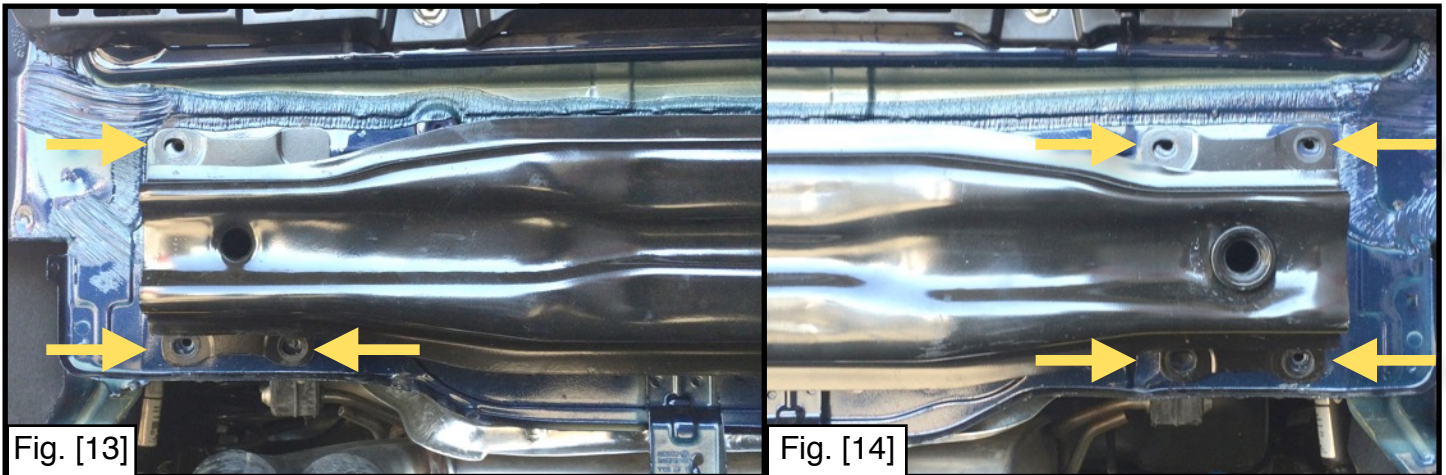

Fig. [11]

Step 5. Starting at the driver side, gently peel the bumper fascia away from the vehicle. Once you reach the tail light section, use a flathead screwdriver or other tool to release the tabs in this section. Move to the passenger side and repeat this process. Unsnap the remaining tabs along the center section of the bumper by pulling rearward. You may need to release the tabs with a flathead in this center section as well. See Figure [12].



Step 6. Discard the foam bar and remove the (7) bolts securing the impact bar in place. Lift the impact bar upward to remove from the vehicle. See Figure [13] & [14].



Step 7. Feed the coil end of the supplied 1/2" bolt fisher through the larger opening on the underside of the frame rail and out the rear of the frame rail. Attach (1) 1/2"-13x2" Gr.5 Carriage Bolt and (1) 1/2"SQx2"x3.5" Plate Washer, then pull into position in the frame rail. Repeat on opposite side. See Figure [15] & [16].

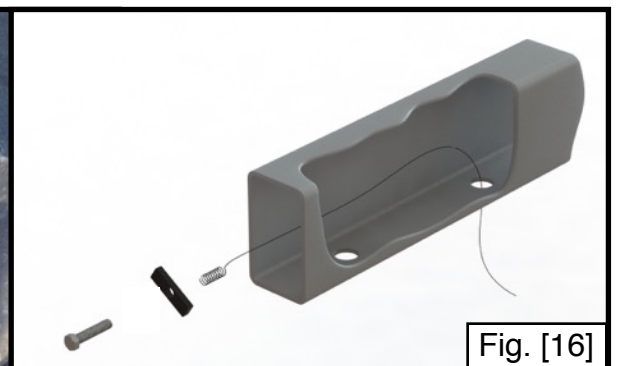
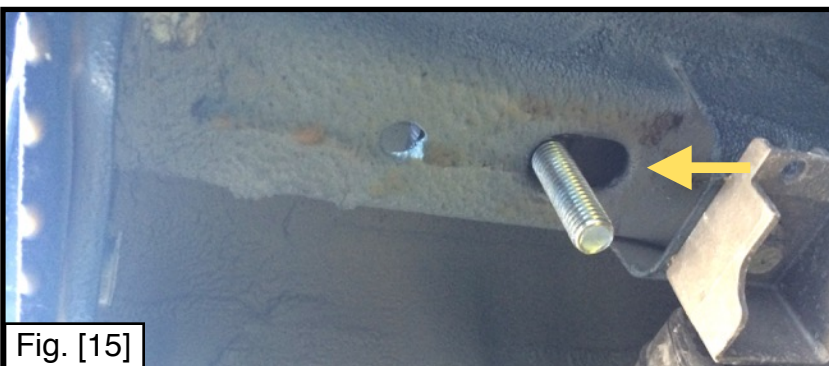

Step 8. Thread (1) M8-1.25x40mm Hex Cap Screw through the back of the outside impact bar weld nuts to act as temporary hanging bolts. See Figure [17].

Fig. [17]

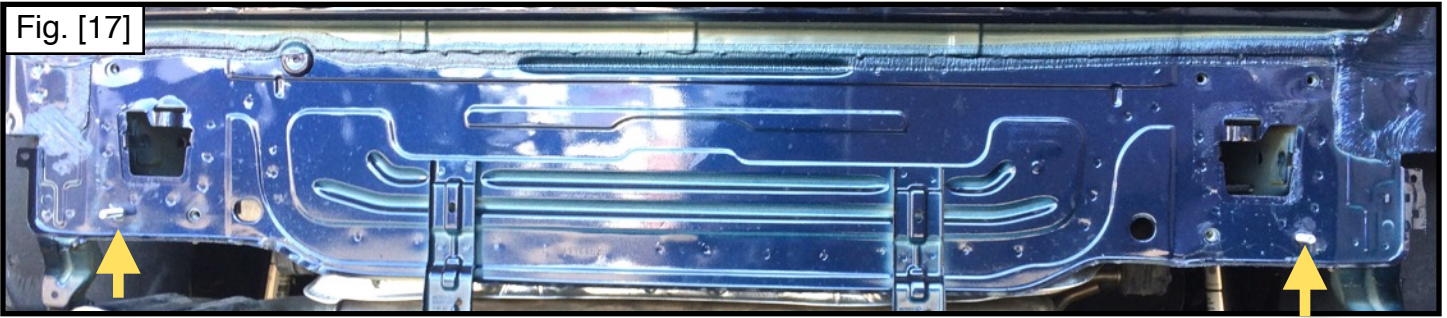

Step 9. Place the hitch on to the hanging bolts and then place the impact bar over the hitch. Secure the hitch and impact bar assembly by threading (1) M8-1.25x40mm Hex Cap Screw, (1) 5/16" lock washer, and (1) 5/16" flat washer through each of the (5) remaining weld nuts and hand tighten. Remove the hanging bolts and install in the same fashion as the other hardware. See Figure [18] & [19].

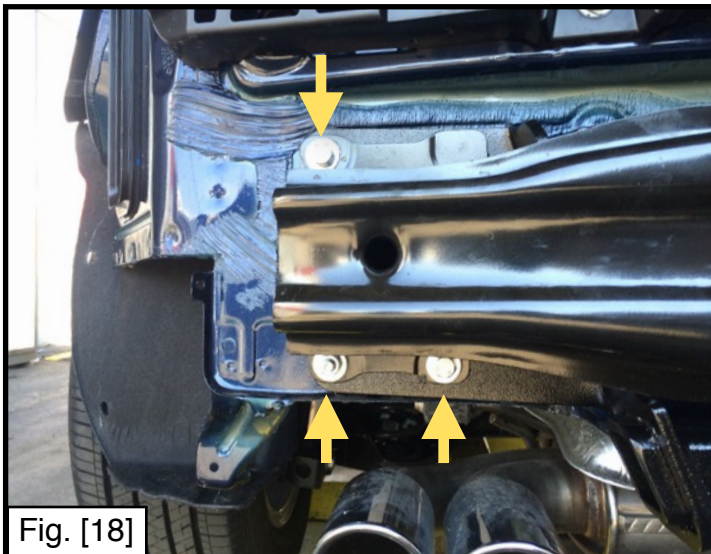

Fig. [18]

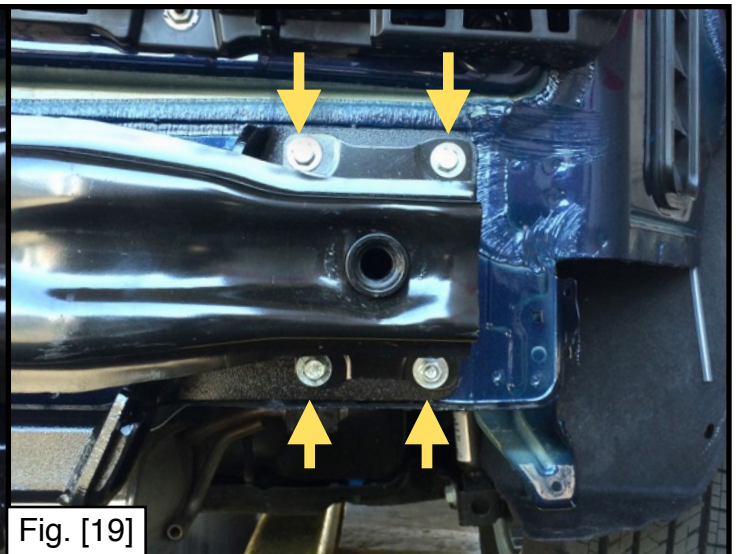

Fig. [19]

Step 10. Install the supplied support straps by placing the fished 1/2" Carriage Bolts through the support strap and securing with (1) 1/2" USS Flat Washer, (1) 1/2" Lock Washer, and (1) 1/2"-13 Hex Nut. Secure the hitch end with (1) 3/8" SAE Flat Washer and (1) 3/8"-16x1" Hex Cap Screw through the hitch strap and hand tighten (1) 3/8"-16 Serrated Nut on the hitch side. See Figure [20] & [21].



Fig. [20]

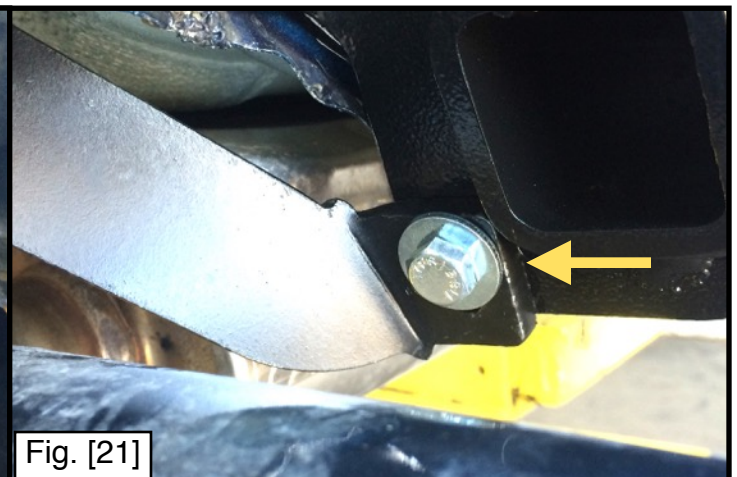

Fig. [21]

Step 11. Once all hardware has been installed and hand tightened, torque all hardware to the following specifications.

3/8": 30 ft-lbs.

1/2": 75 ft-lbs.

M8: 18 ft-lbs.

Step 12. Mark and trim a a 3-1/4"x3" section from the center of the bumper with 1"x1" sections from the bottom corners to allow room for the chain plate. Apply the supplied Trim-Lok to the cut plastic edge and trim excess. See Figure [22].

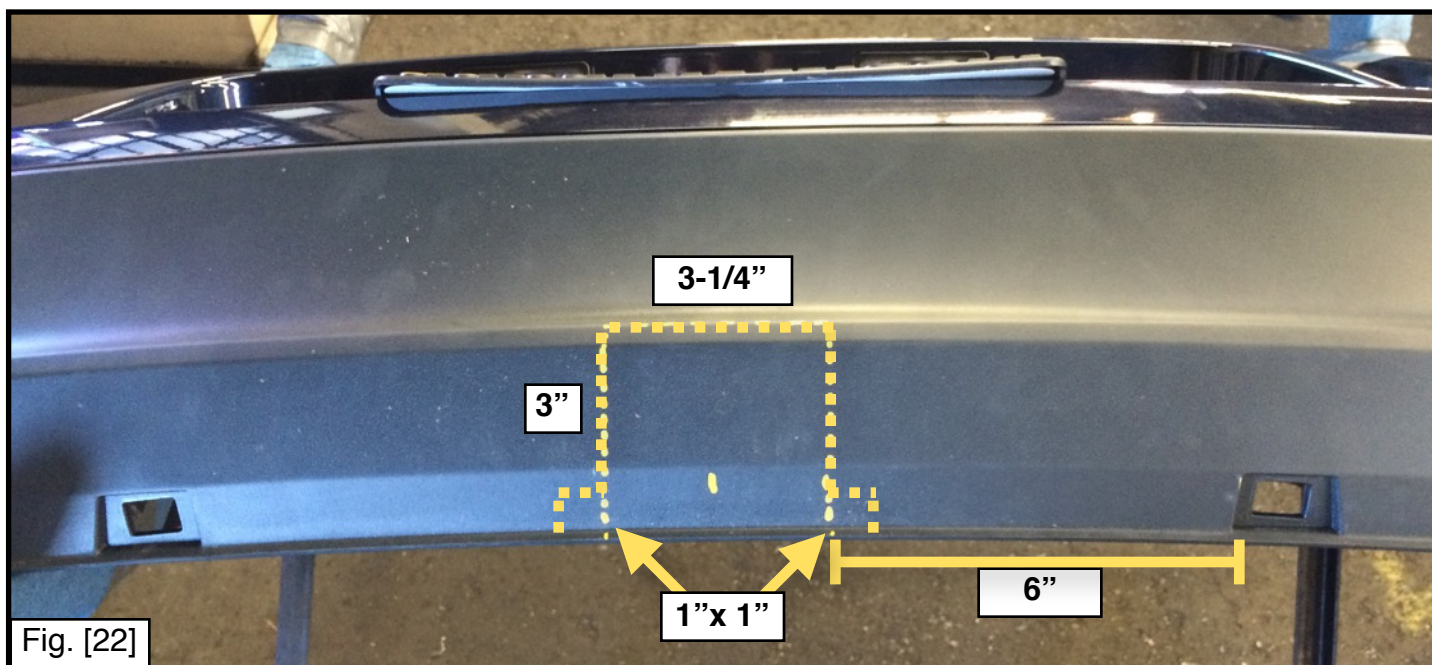

Step 13. Reinstall the bumper fascia and tail light assemblies by following these instructions in reverse starting at Step 5.

Congratulations on the completed installation of the Volkswagen Golf Stealth EcoHitch! It is designed with a lifetime warranty for a lifetime of enjoyment. If you have any questions or suggestions please contact our tech support at support@tlcentral.com or by phone at (253) 854-1832.



WARRANTY/DISCLAIMER INFORMATION

Torklift Central requires proof of purchase for warranty claim registration, with pictures of any defective product before issuing a replacement. Torklift will not accept claims on any product without proof of purchase, which can be faxed, scanned, emailed or mailed to the information provided below. Torklift Central warrants its hitches, custom hitch receivers and accessories (excluding electrical wire harnesses which carry a warranty from their specified manufacturer) from date of purchase against defects in material and workmanship under normal use and service for the ownership life of the original consumer purchaser. Torklift Central will replace free of charge any part that proves defective in material or workmanship when presented to Torklift Central, transportation charges prepaid by purchaser, at the address below. **This warranty is limited to defective parts replacement only. Labor charges and/or damage incurred in installation or replacement, as well as incidental and consequential damages connected therewith are excluded.** This warranty does not include normal wear and tear or the finish and paint. Rusting, cracking or peeling of the finish is also excluded. Some states do not allow the exclusion or limitation of incidental or consequential damages, so the above limitation or exclusion may not apply to you. Any damage to Torklift Central products as a result of misuse, abuse, neglect, accident, improper installation or any use violative of instructions furnished by Torklift Central will void the warranty. This warranty gives you specific legal rights and you may also have rights, which vary from state to state. With warranty service, you may be able to go to a small claims court, a state court or a federal district court.

Although Torklift Central trailer hitches are both tested and rated for towing within the specific capacity label found on each trailer hitch. Torklift Central assumes no liability for vehicle manufacturers warranty due to the use of a Torklift Central trailer hitch being used for towing behind any vehicle or using the trailer hitch in a manner that it was not designed for. Although this specific trailer hitch has a load rating, which includes trailer tongue weight, and a trailer weight carrying capacity, Torklift Central is not responsible for the voiding of any warranty on any vehicle due to factory towing limitations. All vehicle warranties are the sole property and responsibility of the owner of the vehicle that the Torklift Central trailer hitch is installed upon. Torklift Central does not endorse towing behind any vehicle if the vehicles manufacturer states that towing is not recommended. Check your vehicle's owner's manual for the proper tow rating of your vehicle.

ADDRESS: 315 Central Ave N. Kent, WA 98032

WARNING Your vehicle may have a lower tow rating than this trailer hitch. If your vehicle's tow rating is less than the rated towing capacity on your Torklift Central trailer hitch, your trailer hitch capacity is limited to your vehicle's factory rated towing capacity.

FOR EXAMPLE: the label on your Torklift Central trailer hitch states it's capacity is rated for 500 pounds tongue weight and 5,000 pounds towing weight. However your vehicle's factory rated towing capacity is limited to only 350 pounds tongue weight and 3,500 pounds towing weight. In this example your maximum towing capacity of your Torklift Central trailer hitch is limited to 350 pounds tongue weight and 3,500 pounds towing weight as stated by your vehicle's maximum factory tow rating.

DANGER Never exceed your vehicle's manufacturer's recommended towing capacity which may be a lower rating than this trailer hitch

Unsure of your tow rating? Download our towing app from the app store to find your vehicles tow rating.
www.torkliftcentral.com/app.php