

TORKLIFT **INTERNATIONAL**

**OVER 35 YEARS OF INNOVATION, QUALITY, SAFETY.
IMPORTANT OWNER-OPERATOR INSTALLATION**

INSTRUCTIONS

A7710R / A7710RS

Warning!!

This battery box is made of aluminum and is Conductive! Do not allow the battery terminals to touch the aluminum Battery Box. Be careful not to touch the battery box with a wrench while tightening the battery terminals, as this could cause a short!

| ! DANGER / POISON | | | |
|---|--|---|--|
|  SHIELD EYES EXPLOSIVE GASES CAN CAUSE BLINDNESS OR INJURY |  NO <ul style="list-style-type: none">• SPARKS• FLAMES• SMOKING |  SULFURIC ACID CAN CAUSE BLINDNESS OR SEVERE BURNS | FLUSH EYES IMMEDIATELY WITH WATER  GET MEDICAL HELP FAST |
| KEEP OUT OF THE REACH OF CHILDREN. DO NOT TIP. KEEP VENT CAPS TIGHT AND LEVEL. | | | |



REVISED version 6 BY: DK 11/24/2015

TECH SUPPORT (800) 246-8132

**AFTER INSTALL, PLEASE GIVE
THIS BOOKLET TO YOUR CUSTOMER**

Warning!! Improper installation of Solar Equipped Power Armors may result in battery over-charging!

Single Solar Panel Option 1:

If you plan to use two or more batteries with a single 10-Watt Solar Panel, you will NOT need to purchase any additional parts.

Single Solar Panel Option 2:

If you plan to use one battery with a single 10-Watt Solar Panel, it is required that you use a 6 Amp Regulator (PN A7715) to prevent your battery from gassing and over charging.

Double Solar Panel Option 1:

If you plan to use 4 or more batteries with two 10-Watt Solar Panels, you will need to purchase a second solar panel (A7713) and either the Y-Harness adapter (A7714) or optionally a 6-amp regulator (A7715)

Double Solar Panel Option 2:

If you plan to use less than 4 batteries with two 10-Watt Solar Panels, you will need to purchase a second solar panel (A7713) and a 6-amp regulator (A7715)

Optional Solar Parts

PN - A7713 - Additional 10-Watt Solar Panel (Requires the use of **A7714** or **A7715** when installed as a second solar panel)

PN - A7714 - Y-Harness Adapter (Connects Two 10-Watt solar panels, not needed if using **A7715**)

PN - A7715 - 6-amp regulator **required when using less than two batteries per solar panel** (Regulates amperage to prevent gassing and over charging, will work with **one** or **two** 10-Watt Solar Panels, **A7714** not required)

Replacement Battery Mats

The battery mat included with the Power Armor Battery Box is acid neutralizing, and will help reduce any corrosion from spilled battery acid. It is a “wear” item and may eventually need to be replaced. New battery mats are available through Torklift International. Part numbers below.

PN: A7717- A7710RS/A7710RS Battery Mat

Inventory List

A7710R / A7710RS

| Item: | Quantity: |
|---|-----------|
| Power Armor Max Battery Box | 1 |
| Power Armor Max Lid | 1 |
| Two Piece Divider Half | 2 |
| Drop In Stiffener | 1 |
| Battery Mat 58" | 1 |
| Battery Strap | 5 |
| 1/4" x 1" SS Self-Drilling Screw | 8 |
| 7/16" Square Profile O-ring | 8 |
| 1/4"-20 x 1" SS Hex Bolt | 6 |
| 1/4" SS SAE Flat Washer | 12 |
| 1/4"-20 SS Hex Nut | 6 |
| 1/4" Lock Washer | 6 |
| 1/4"-20 SS Wing Nut | 2 |
| 1/4"-20 x SS 3/4" Carriage Bolt | 2 |
| 10 Watt Solar Panel (<i>A7710RS Only</i>) | 1 |
| 15A Fuse Holder (<i>A7710RS Only</i>) | 1 |
| Positive Wire Female to Male Extension (<i>A7710RS Only</i>) | 1 |

Step 1:

Remove the **Power Armor Max Lid** by sliding the lid away from the side of the box with the lock; then lifting the front edge and unhooking the lid from the tabs on the rear of the box.

Step 2:

Test fit your batteries in the **Power Armor Max Battery Box**. If you plan on using the **Two Piece Divider**, all of the batteries will need to be on the same side of the box. The battery terminals should face the side of the box with the 2” holes. For solar models, the batteries should be closest to the side of the box with the lock. There are a series of slots cut into the bottom of the **Power Armor Battery Box** for the included **Battery Straps**. Make an incision in the **Battery Mat** over each of the slots you will need for the **Battery Straps**. Install the non-buckled end of the **Battery Straps** down through one of the slots and back up through the bottom of the **Power Armor Max Battery Box**. Use the straps to secure the batteries and ensure that they are situated correctly for your application. Once the battery box is installed, the straps will be difficult to adjust. Remove the batteries and **Battery Mat** before proceeding.

Step 3:

The two 2" holes in the front/back panel of the **Power Armor Max Battery Box** are used to allow the battery cables to enter the battery box. They can be mounted to either the front or rear of the trailer as long as there is sufficient room to open and remove the **Power Armor Max Lid**.

Place the **Power Armor Max Battery Box** where it is to be mounted. If the battery box is being installed on an open frame trailer, drill three 1/4" holes per side through the bottom of the battery box and into the trailer. Secure the battery box as seen in figure 3.1

Figure 3.1

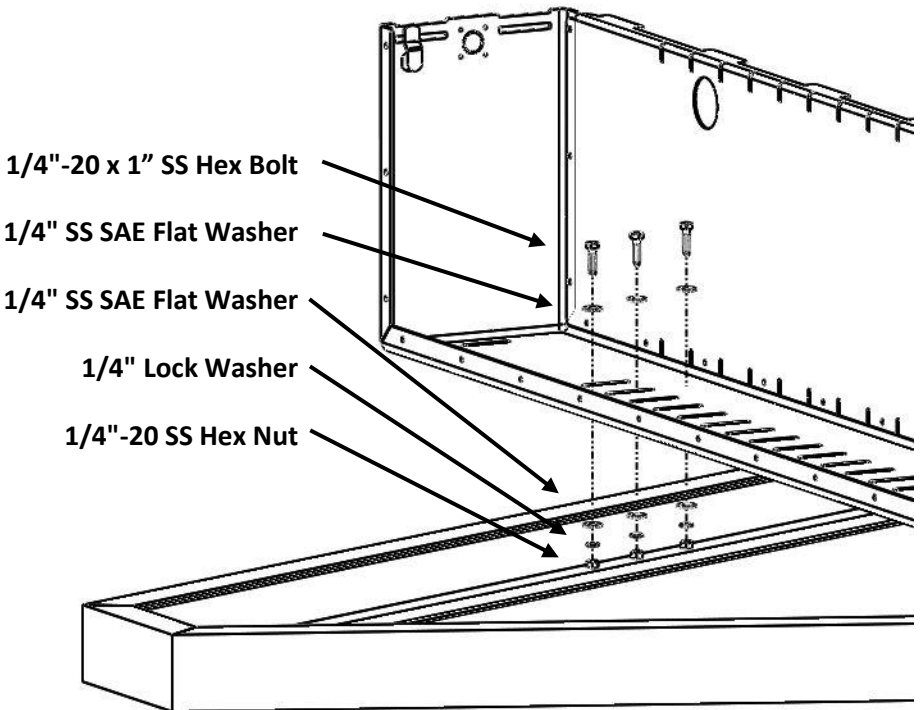

If the battery box is being installed on a boxed frame trailer, install three **1/4" x 1" SS Self-Drilling Screws** per side through the bottom of the battery box and into the trailer frame. Place a **7/16" square profile O-ring** around the head of each screw/bolt to protect the battery mat from abrasion. See figure 3.2

Figure 3.2

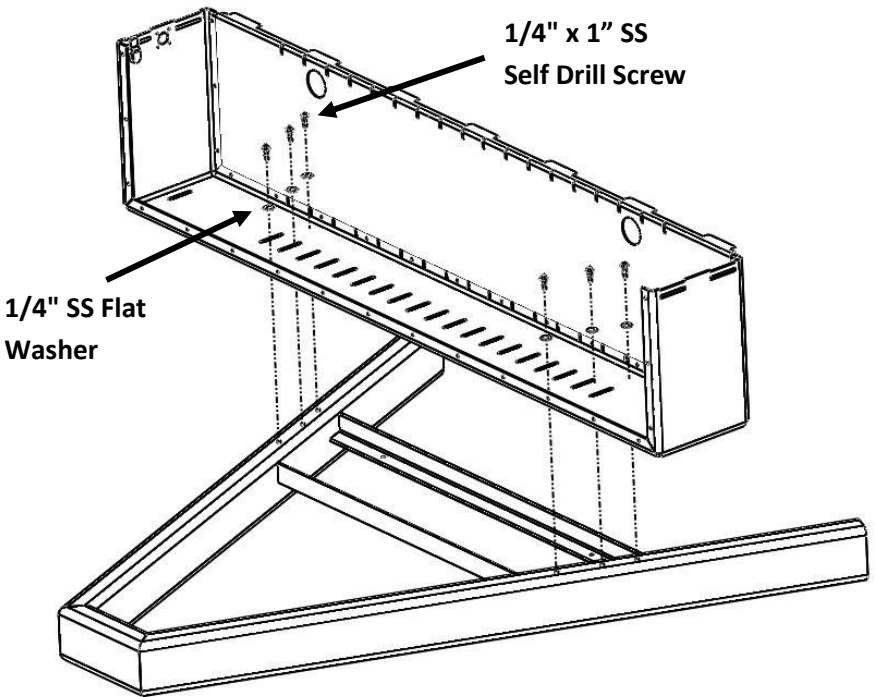

Step 4

Reinstall the **Battery Mat** and Batteries. To prevent any possible contact between the battery terminals and lock, the battery terminals should be oriented towards the side of the box with the 2" holes. Tightly secure the batteries with the battery straps.

Step 5:

If desired, a **Two Piece Divider** can be installed into the battery box. To install the **Two Piece Divider**, place the tabbed end of one of the **Two Piece Divider Halves** into the slots in the side of the battery box. Use the other **Two Piece Divider Half** to tab into the opposite side of the box. Bolt the two divider halves together using the supplied **1/4"-20 x 3/4" SS Carriage Bolts** and **1/4"-20 SS Wing Nuts**. The wing nuts should be on the opposite side of the divider from the batteries to avoid abrasion. See figure 5.1

Figure 5.1

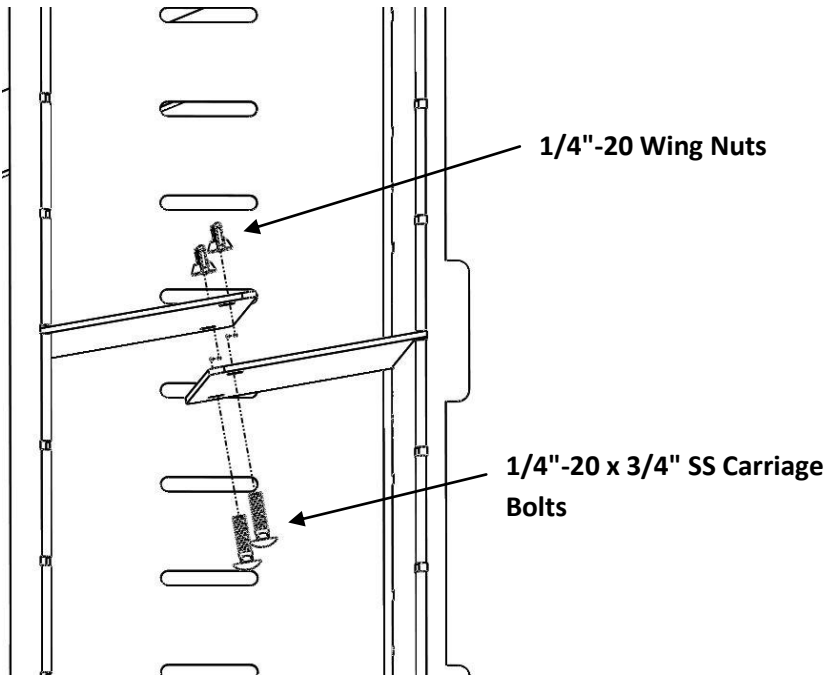

Step 6:

While flexing the front and back side of the battery box slightly apart, install the **Drop in Stiffener** into one of the four middle upper slots in the battery box as shown in figure 6.1. If the **Two Piece Divider** is already installed in one of these slots, the battery box stiffener will not be needed.

Figure 6.1

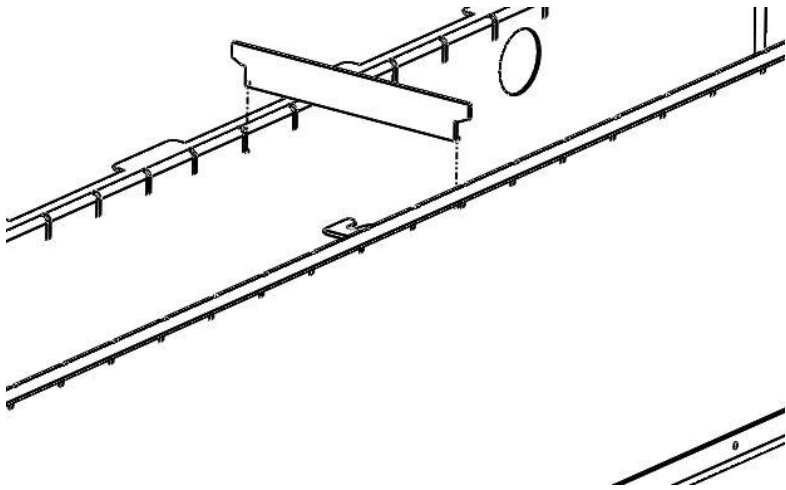

Step 7:

The **Power Armor Max** and **Power Armor Max Solar** battery boxes are capable of supporting multiple battery configurations. Depending on the configuration, additional battery cables may be required but are not included.

----- 12-VOLT BATTERIES -----

Wiring for **ONE** 12v battery: _____ **Figure 7.1**

Wiring for **TWO** 12v batteries: _____ **Figure 7.2**

Wiring for **THREE** 12v batteries: _____ **Figure 7.3**

Wiring for **FOUR** 12v batteries: _____ **Figure 7.4**

Wiring for **FIVE** 12v batteries: _____ **Figure 7.5**

----- 6-VOLT BATTERIES -----

Wiring for **TWO** 6v batteries: _____ **Figure 7.6**

Wiring for **FOUR** 6v batteries: _____ **Figure 7.7**

ONE 12v Battery Wiring Diagram (Figure 7.1)

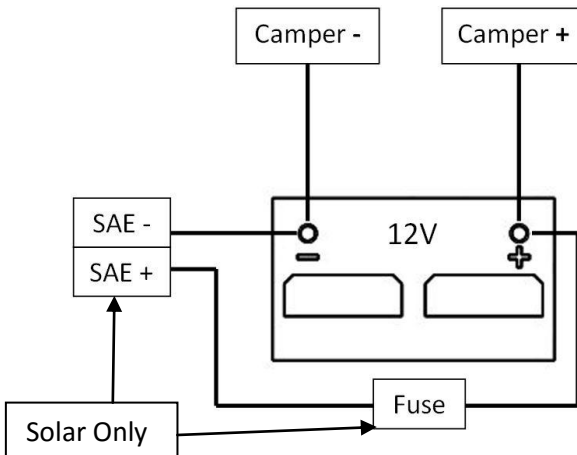

TWO 12v Batteries Wiring Diagram (Figure 7.2)

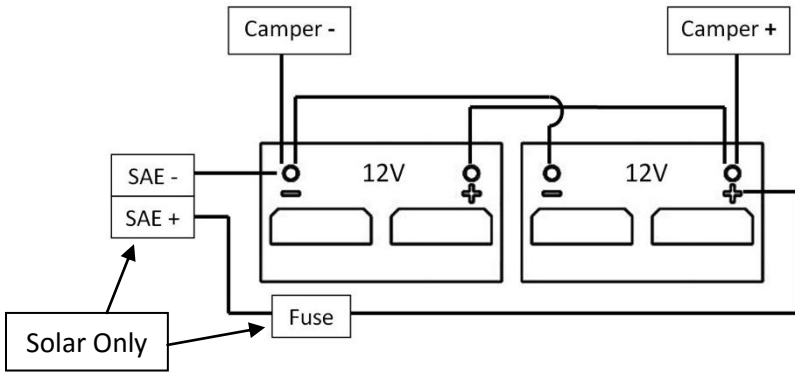

THREE 12v Batteries Wiring Diagram (Figure 7.3)

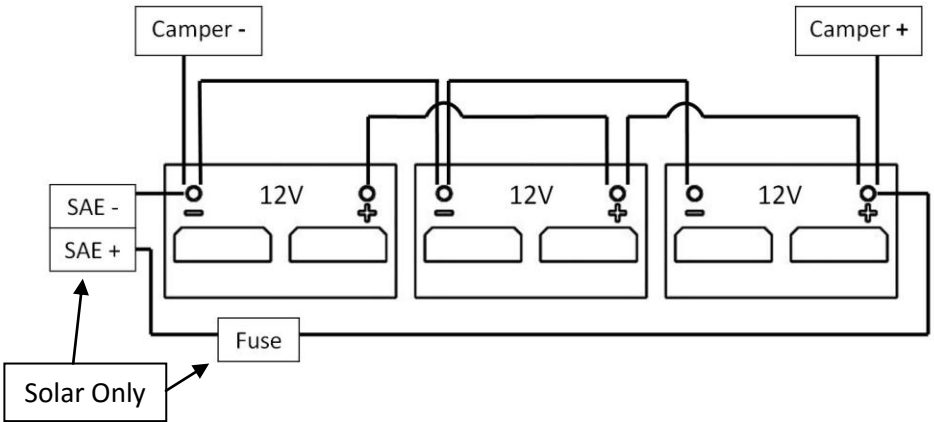

FOUR 12v Batteries Wiring Diagram (Figure 7.4)

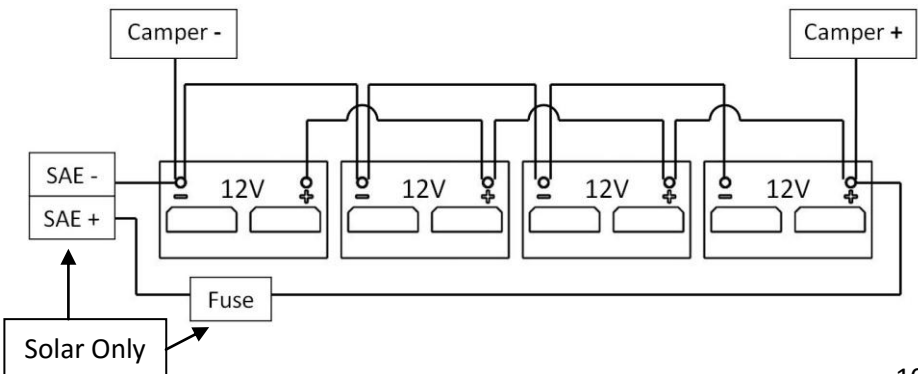

FIVE 12v Batteries Wiring Diagram (Figure 7.5)

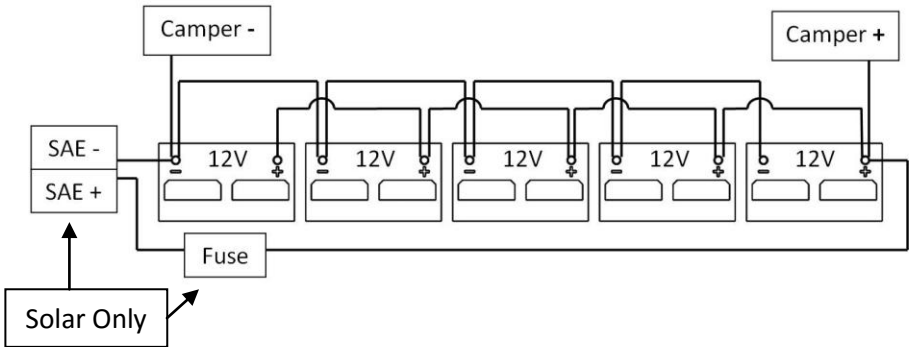

TWO 6v Batteries Wiring Diagram (Figure 7.6)

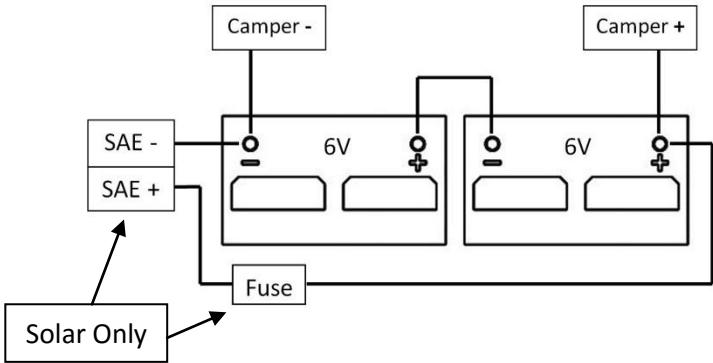

FOUR 6v Batteries Wiring Diagram (Figure 7.7)

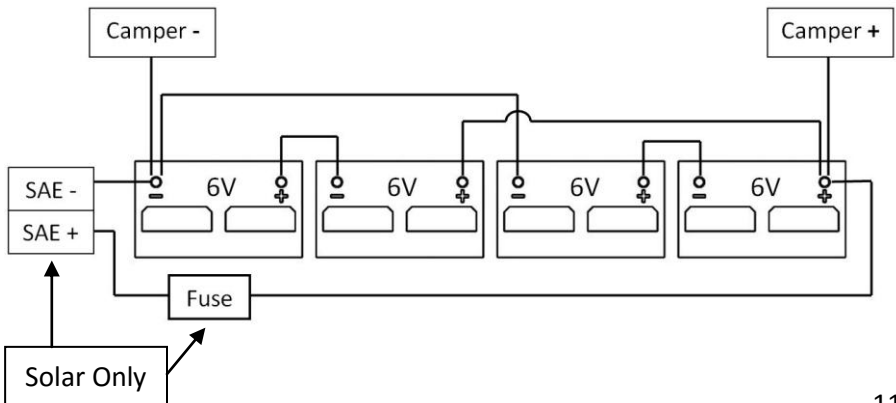

Step 8

To attach the **Power Armor Max Lid** to the **Power Armor Max Battery Box**, place it over the **Power Armor Max Battery Box**, and align it so the tabs on the **Power Armor Max Battery Box** fit through the slotted holes in the **Power Armor Max Lid** as seen in Figure 8.1

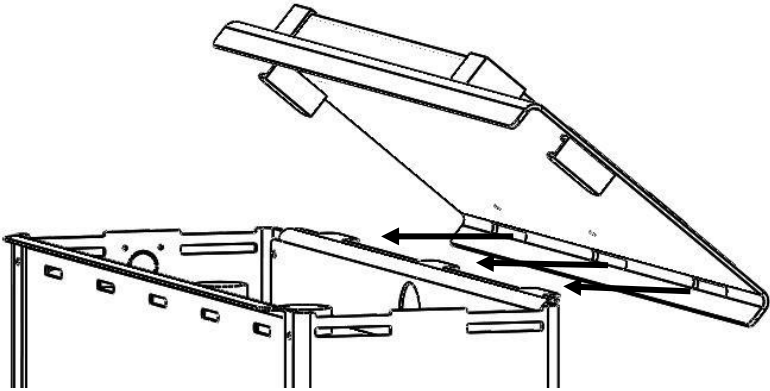

Figure 8.1

Step 9

Slide the **Power Armor Max Lid** away from the lock and lower it down over the front of the **Power Armor Max Battery Box**. Once the **Power Armor Max Lid** is sitting flat, slide it towards the lock so the Locking tabs on the lid slide into the **Power Armor Max Battery Box** as seen in figure 9.1

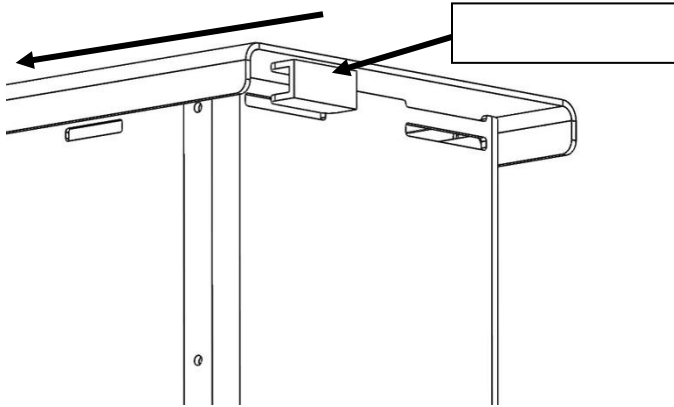
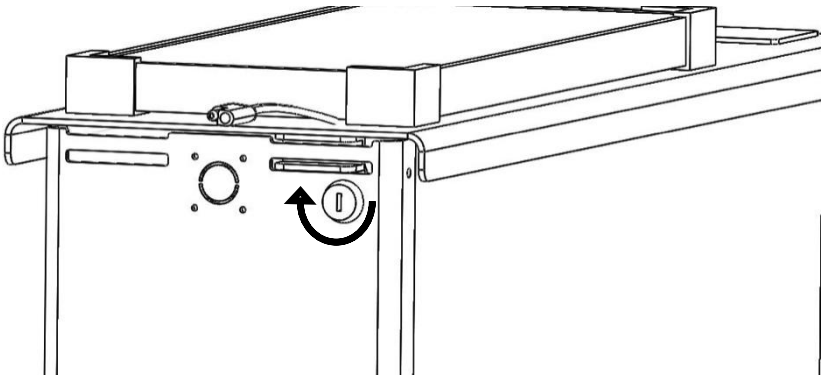

Figure 9.1

After the **Power Armor Max Lid** has slid into place, lock the key cylinder as seen in figure 9.2.

Solar Models Only: Connect the SAE connector from the Solar Panel into the SAE connector on the side of the Power Armor Solar Battery Box.

Figure 9.2



Torklift International Limited Lifetime Warranty Information

322 N Railroad Ave. Kent, WA 98032

Torklift will require proof of purchase to register, with pictures of any defective product before issuing a replacement. Torklift will not register any product without proof of purchase, which can be faxed, scanned, emailed, or mailed to the information provided below. Torklift warrants its hitches, custom hitch receivers, frame mounted tie downs, turnbuckles, and accessories (excluding wire harnesses which carry a 90 day warranty) from date of purchase against defects in material and workmanship under normal use and service for the ownership life of the original consumer purchaser. All plastic, rubber, and/ or electrical components maintain a warranty of up to one year from the date of the purchase. **ALL COMMERCIAL APPLICATIONS ARE WARRANTED FOR A PERIOD OF 90 DAYS FROM THE DATE OF INSTALLATION/SERVICE.** Torklift will replace **FREE OF CHARGE** any part which proves defective in material or workmanship when presented to Torklift, **TRANSPORTATION CHARGES PREPAID** by purchaser, at the address above. **THIS WARRANTY IS LIMITED TO DEFECTIVE PARTS REPLACEMENT ONLY. LABOR CHARGES AND/OR DAMAGE INCURRED IN INSTALLATION OR REPLACEMENT, AS WELL AS INCIDENTAL AND CONSEQUENTIAL DAMAGES CONNECTED THEREWITH ARE EXCLUDED.** This warranty does not include the finish or paint on our products. Rusting, cracking or peeling of the finish is also excluded. Some states do not allow the exclusion or limitation of incidental or consequential damages, so the above limitation or exclusion may not apply to you. Any damage to Torklift products as a result of misuse, abuse, neglect, accident, improper installation or any use violative of instructions furnished by Torklift or **WHEN USED IN ANY COMMERCIAL APPLICATION WILL VOID THE WARRANTY.** This warranty gives you specific legal rights, and you may also have rights which vary from state to state. With warranty service, you may be able to go to a small claims court, a state court or a federal district court.

322 N Railroad Ave. Kent, WA 98032

Phone (800) 246-8132

Fax (253) 854-8003

Or visit our website: www.TorkLift.com

Dear Valued Customer,

Thank you for making TorkLift your choice for truck, camper packages and accessories for your vehicle. By choosing TorkLift products, you have chosen a company that has been serving the RV industry for nearly 40 years and whose name has become synonymous with strength, quality and advanced design and installation.

Please take a few moments of your time to complete the Product Registration Warranty Card on the next page. When registering your newly purchased TorkLift products, you can be assured that your contact information is secure and that you and your product are getting the attention and respect that you deserve.

Thank you again for choosing TorkLift quality products.

Register for your lifetime warranty and receive a free Torklift International gift.

To Fax: Send copies of the questionnaire, warranty card and receipt to
253-854-8003

To E-mail: Send copies of the questionnaire, warranty card and receipt to
warranty@torklift.com

To Mail: Send to Torklift International 322 N Railroad Ave. Kent, WA 98032



OFFICIAL WARRANTY REGISTRATION CARD

PLEASE FILL OUT THIS FORM COMPLETELY AND RETURN TO TORKLIFT WITHIN

30 DAYS OF PURCHASE ACCOMPANIED BY A COPY OF YOUR ORIGINAL RECEIPT

1. PART(S) PURCHASED

TODAY'S DATE: _____

PART #: _____ PART #: _____

PART #: _____ PART #: _____

PART #: _____ PART #: _____

2. PURCHASER INFORMATION

NAME: _____

ADDRESS: _____

CITY: _____ STATE: _____ ZIP / POSTAL CODE: _____

PHONE: (____) _____ - _____ EMAIL: _____

3. TRUCK INFORMATION

YEAR: _____ MAKE: _____

MODEL: _____ BED LENGTH: _____

4. CAMPER INFORMATION

YEAR: _____ MAKE: _____ MODEL: _____

5. DEALER INFORMATION

PURCHASED FROM: _____

ADDRESS: _____

CITY: _____ STATE: _____ ZIP / POSTAL: _____

INSTALLED BY: _____ OWNER ABOVE DEALER ANOTHER DEALER

IF ANOTHER DEALER, WHO: _____