



**OVER 35 YEARS OF INNOVATION, QUALITY, SAFETY.  
IMPORTANT OWNER-OPERATOR INSTALLATION INSTRUCTIONS**

**BASEMENT GLOWSTEP  
A7510- POWDERCOATED  
A7513- ALUMINUM FINISH  
FOR CAMPERS WITH  
BASEMENT STORAGE & STEP BUMPER**



REVISED vers5 BY: DSK 11/23/15

**TECH SUPPORT (800) 246-8132**

**AFTER INSTALL, PLEASE GIVE  
THIS BOOKLET TO YOUR CUSTOMER**

Thank you for the purchase of this Basement GlowStep system. Please read this manual thoroughly as there are particular instructions that must be adhered to for proper installation, use, and storage.

Your Basement GlowStep is comprised of a GlowStep, Hinge brackets and assorted fasteners for installation. The Basement GlowStep is designed to give you an extra step up for those that have a large basement storage and bumper. Because of the large gap between the bumper and the threshold of the door, we designed the Basement GlowStep to offer an easier and safer step into and out of the camper. The Basement GlowStep can be locked into its “In-use” Position with supplied Ring Pin 1/4” and Hitch Pin Clip and can be quickly collapsed for access to the basement storage. Slide the Ring Pin 1/4” and Hitch Pin Clip into the designated holes in the rearward hinge brackets for storage when not in use. Pair this Basement GlowStep with a GlowGuide and the GlowStep Scissor Steps and have the ease of use; stability and the security of having the best step and handrail system on the market.

## BASEMENT GLOWSTEP INVENTORY

- |                                 |                           |
|---------------------------------|---------------------------|
| 4- HEX BOLT 3/8”-16 X 1-1/4” SS | 4- FLAT WASHER 3/8” SS    |
| 2- RING PIN 1/4”                | 1- BOLT FISHER 3/8” X 48” |
| 4- HEX NUT 3/8”-16 SS           | 2- HITCH PIN CLIP         |
| 4- LOCK WASHER 3/8” SS          |                           |

**\* IMPORTANT \***

This step kit requires a 8" x 24" foot print on the bumper or other mounting surface.

**WEIGHT LIMIT: 325 LBS(147kg)**

**INSTALLATION INSTRUCTIONS FOR BUMPER MOUNTING**

1. Set the Basement GlowStep in place on top of the bumper. Make sure there is no interference while in working position and the collapsed position.
2. Drill one hole, Then use the \*BOLT FISHER 3/8" X 48" to pull one HEX BOLT 3/8"-16 X 1-1/4" SS, with one LOCK WASHER 3/8" SS through the bumper, Basement GlowStep Bracket and previous hole that was drilled. Hand tighten with one FLAT WASHER 3/8" SS and one HEX NUT 03/8"-16 SS. Repeat on other three holes.
3. Tighten the fasteners to 20 FT Lbs.(27nm) with a torque wrench.

To place the step into working position, hold the step in the upright position and attach the arched locking bar to the outside Hinge link with a RING PIN 1/4", and a HITCH PIN CLIP and clip into place.

To place the step into the collapsed position, Remove the RING PIN 1/4", and a HITCH PIN CLIP. Repeat on opposite side.

**Side view of the Basement GlowStep in the Collapsed position**

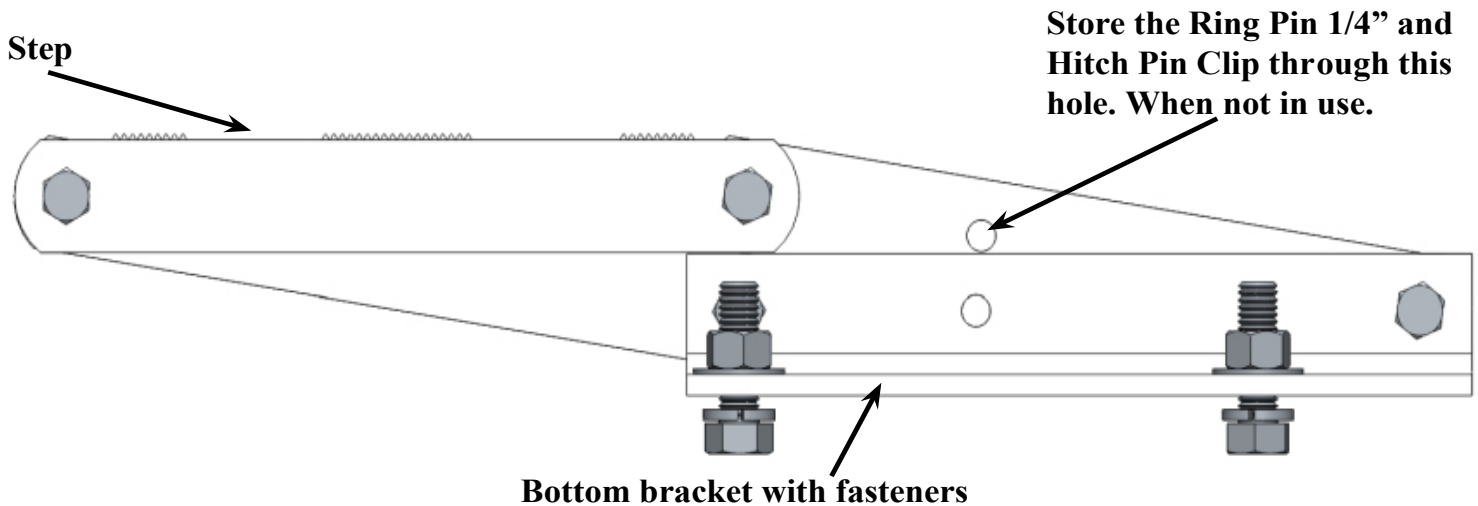

**Exploded view of fasteners installed in Basement GlowStep on Bumper**

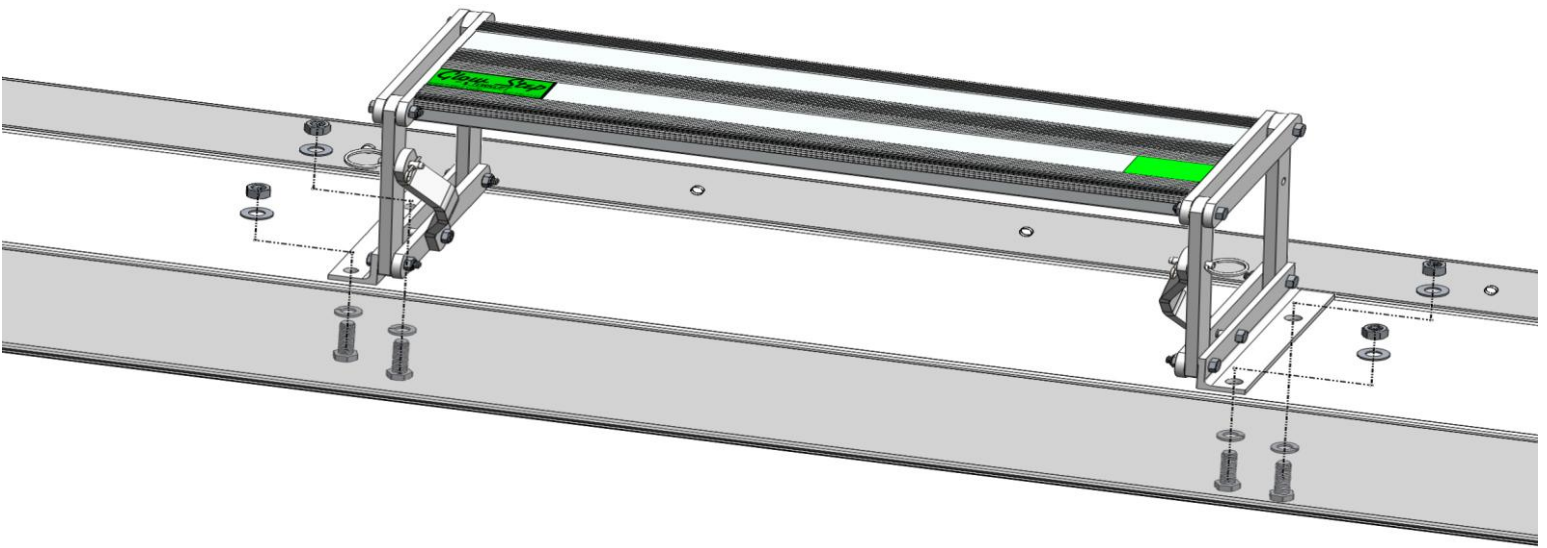

**Collapsed angle view of Basement GlowStep**

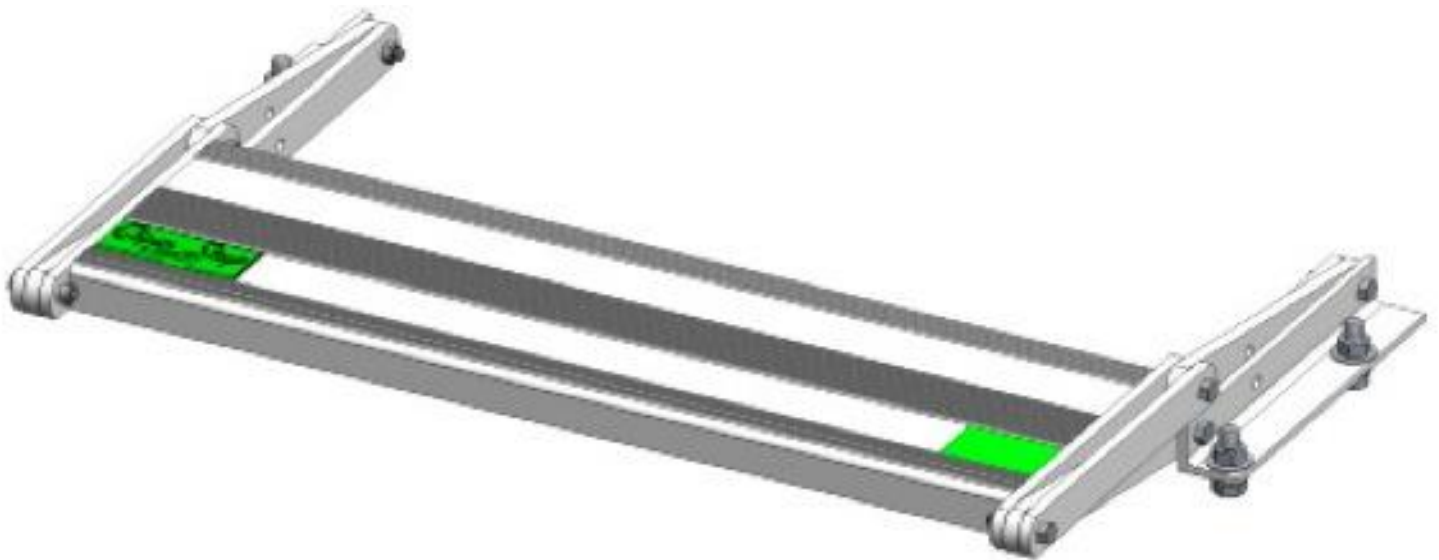

**In-Use angle view of Basement GlowStep**

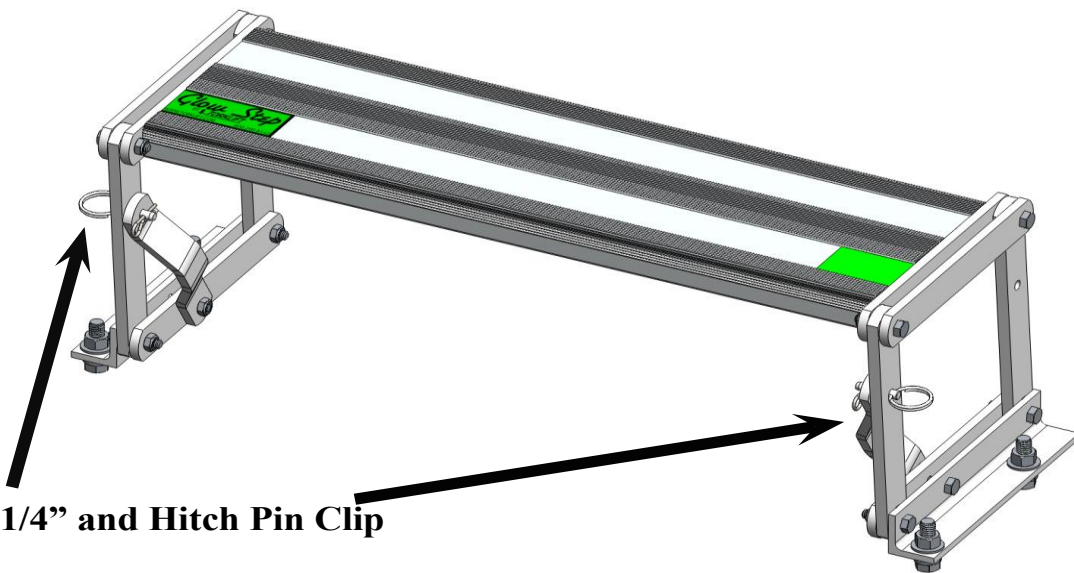

**Ring Pin 1/4" and Hitch Pin Clip**

# TORKLIFT'S BOLT FISHING GUIDE

Your guide to understanding the installation of our frame mounted tie downs.

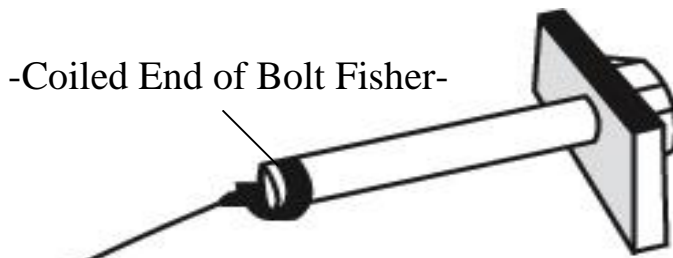

Note: The hardware may vary as to what is being fished along with the bolt. In this instance a 1" X 2" plate washer is being fished along with the hex bolt. Different applications may require fishing through various star washers and flat washers for example.

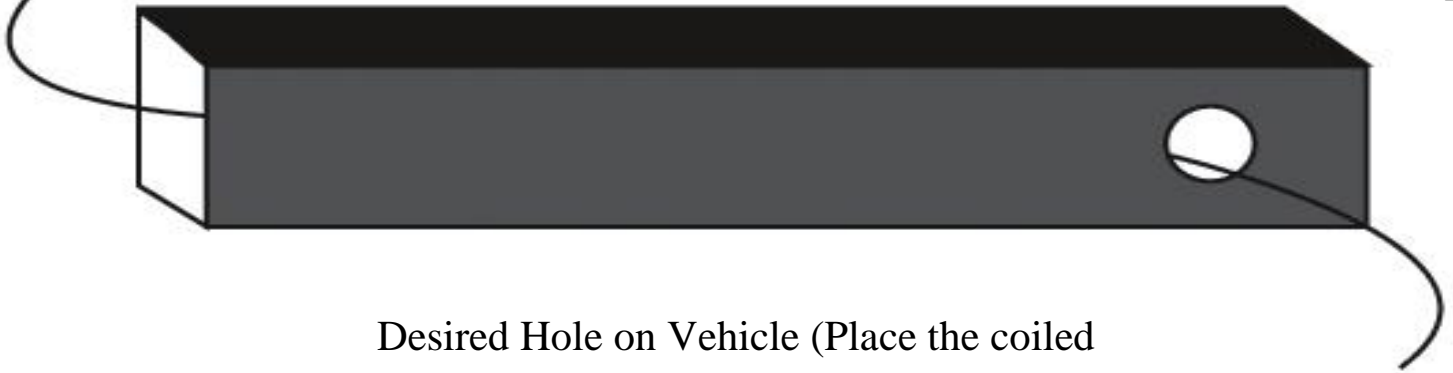

Desired Hole on Vehicle (Place the coiled end of the bolt fisher through this hole).

This side of the Bolt Fisher should come out of a hole where the required hardware (for example 1" X 2" plate washer) can pass through.



This bottom example shows the bolt when it's completely fished through the vehicle. You may find it easier to keep the bolt fisher attached until you get the tie down receiver in place so that the bolt doesn't fall into the vehicle frame.

**WARNING: PULLING TOO HARD ON THE BOLT FISHER CAN RESULT IN LOST FASTENERS, OR BROKEN BOLT FISHER.**

# **Torklift International Limited Lifetime Warranty Information**

**322 N Railroad Ave. Kent, WA 98032**

Torklift will require proof of purchase to register, with pictures of any defective product before issuing a replacement. Torklift will not register any product without proof of purchase, which can be faxed, scanned, emailed, or mailed to the information provided below. Torklift warrants its hitches, custom hitch receivers, frame mounted tie downs, turnbuckles, and accessories (excluding wire harnesses which carry a 90 day warranty) from date of purchase against defects in material and workmanship under normal use and service for the ownership life of the original consumer purchaser. **ALL COMMERCIAL APPLICATIONS ARE WARRANTED FOR A PERIOD OF 90 DAYS FROM THE DATE OF INSTALLATION/SERVICE.** Torklift will replace **FREE OF CHARGE** any part, which proves defective in material or workmanship when presented to Torklift, **TRANSPORTATION CHARGES PREPAID** by purchaser, at the address above. **THIS WARRANTY IS LIMITED TO DEFECTIVE PARTS REPLACEMENT ONLY. LABOR CHARGES AND/OR DAMAGE INCURRED IN INSTALLATION OR REPLACEMENT, AS WELL AS INCIDENTAL AND CONSEQUENTIAL DAMAGES CONNECTED THEREWITH ARE EXCLUDED.** This warranty does not include the finish or paint on our products. Rusting, cracking or peeling of the finish is also excluded. Some states do not allow the exclusion or limitation of incidental or consequential damages, so the above limitation or exclusion may not apply to you. Any damage to Torklift products as a result of misuse, abuse, neglect, accident, improper installation or any use violation of instructions furnished by Torklift or **WHEN USED IN ANY COMMERCIAL APPLICATION WILL VOID THE WARRANTY.** This warranty gives you specific legal rights, and you may also have rights, which vary from state to state. With warranty service, you may be able to go to a small claims court, a state court or a federal district court.



**OVER 35 YEARS OF INNOVATION, QUALITY, SAFETY.**

**322 N Railroad Ave. Kent, WA 98032**

**Phone (800) 246-8132**

**Fax (253) 854-8003**

or visit our website: [www.TorkLift.com](http://www.TorkLift.com)

Dear Valued Customer,

Thank you for making TorkLift your choice for truck, camper packages and accessories for your vehicle. By choosing TorkLift products, you have chosen a company that has been serving the RV industry for nearly 40 years and whose name has become synonymous with strength, quality and advanced design and installation.

Please take a few moments of your time to complete the Product Registration Warranty Card on the next page. When registering your newly purchased TorkLift products, you can be assured that your contact information is secure and that you and your product are getting the attention and respect that you deserve.

Thank you again for choosing TorkLift quality products.

**Register for your lifetime warranty and receive a free Torklift International gift.**

To Fax: Send copies of the questionnaire, warranty card and receipt to 253-854-8003

To E-mail: Send copies of the questionnaire, warranty card and receipt to [warranty@torklift.com](mailto:warranty@torklift.com)

To Mail: Send to Torklift International 322 N Railroad Ave. Kent, WA 98032





**OVER 35 YEARS OF INNOVATION, QUALITY, SAFETY.**

**OFFICIAL WARRANTY REGISTRATION CARD**

PLEASE FILL OUT THIS FORM COMPLETELY AND RETURN TO TORKLIFT WITHIN 30 DAYS OF PURCHASE ACCOMPANIED BY A COPY OF YOUR ORIGINAL RECEIPT

TODAY'S DATE: \_\_\_\_\_

**1. PART(S) PURCHASED**

PART#: \_\_\_\_\_ PART#: \_\_\_\_\_  
PART#: \_\_\_\_\_ PART#: \_\_\_\_\_

**2. PURCHASER INFORMATION**

NAME: \_\_\_\_\_

ADDRESS: \_\_\_\_\_

CITY: \_\_\_\_\_ STATE: \_\_\_\_\_ ZIP / POSTAL CODE: \_\_\_\_\_

PHONE: (\_\_\_\_) \_\_\_\_\_ - \_\_\_\_\_ EMAIL: \_\_\_\_\_

**3. TRUCK INFORMATION**

YEAR: \_\_\_\_\_ MAKE: \_\_\_\_\_

MODEL: \_\_\_\_\_ BED LENGTH: \_\_\_\_\_

**4. CAMPER INFORMATION**

YEAR: \_\_\_\_\_ MAKE: \_\_\_\_\_ MODEL: \_\_\_\_\_

**5. DEALER INFORMATION**

PURCHASED FROM: \_\_\_\_\_

ADDRESS: \_\_\_\_\_

CITY: \_\_\_\_\_ STATE: \_\_\_\_\_ ZIP / POSTAL: \_\_\_\_\_

INSTALLED BY:  OWNER  ABOVE DEALER  ANOTHER DEALER

IF ANOTHER DEALER, WHO: \_\_\_\_\_