



Serving With Excellence Since 1976

eco HITCH

Designed Specifically For Your **Green Vehicle**

X7365 - 2" Subaru Crosstrek

X7366 - 1-1/4" Subaru Crosstrek

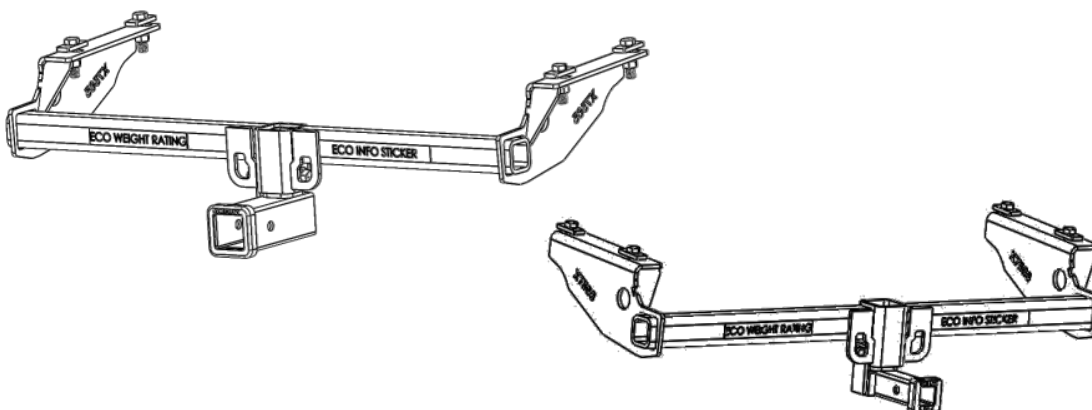







Version (1) BY: RAS 9/5/2017

TECH SUPPORT (800) 246-8132

**AFTER INSTALL, PLEASE GIVE
THIS BOOKLET TO YOUR CUSTOMER**

Parts Inventory

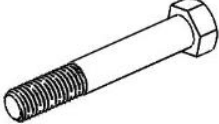
Item Image	Item Description	Item#	Qty
	2" Stealth Eco Hitch (X7365 Only)	X7365 -W1	1
	1-1/4" Stealth Eco Hitch (X7366 Only)	X7366 -W1	1
	2" Receiver Weldment (X7365 Only)	XA3001- W1	1
	1-1/4" Receiver Weldment (X7366 Only)	XA3002- W1	1
	1/2"-D x 7/8" x 2" x 1/4" Plate Washer	0.5 x 0.875 x 2 x 0.25- Plate Washer	4
	1/2" - Internal Tooth Lock Washer Zinc	14084	4
	1/2"-13 x 2" - Hex Head Cap Screw Grade 8	3659	4
	1/2" - SAE - Flat Washer	7465	8

	<p>1/2" - Split Lock Washer Zinc</p>	<p>9302</p>	<p>4</p>
	<p>1/2"-13 - Hex Nut Grade 8</p>	<p>1751</p>	<p>4</p>
	<p>5/8" x SAE Flat Washer Grade 8</p>	<p>9717</p>	<p>1</p>
	<p>5/8" - Lock Washer</p>	<p>6023</p>	<p>1</p>
	<p>5/8"-11 x 4" - Hex Bolt Grade 5</p>	<p>12819</p>	<p>1</p>
	<p>1/2" Bolt Fisher</p>	<p>3818</p>	<p>1</p>

Installation Notes:

Step 1:

Begin by placing a wheel chock on the front wheels. Raise the rear of the car to help ease installation. Place a board or bar under the muffler to prevent damage. Remove the four exhaust hangers on the muffler using WD-40. Start with the single hanger (1) located near the rear differential (see figure 1.1). Move on to the single passenger side hanger (2), finishing with the two hangers on the driver's side (3&4). Gently lower muffler (see figure 1.2) onto the board or bar.

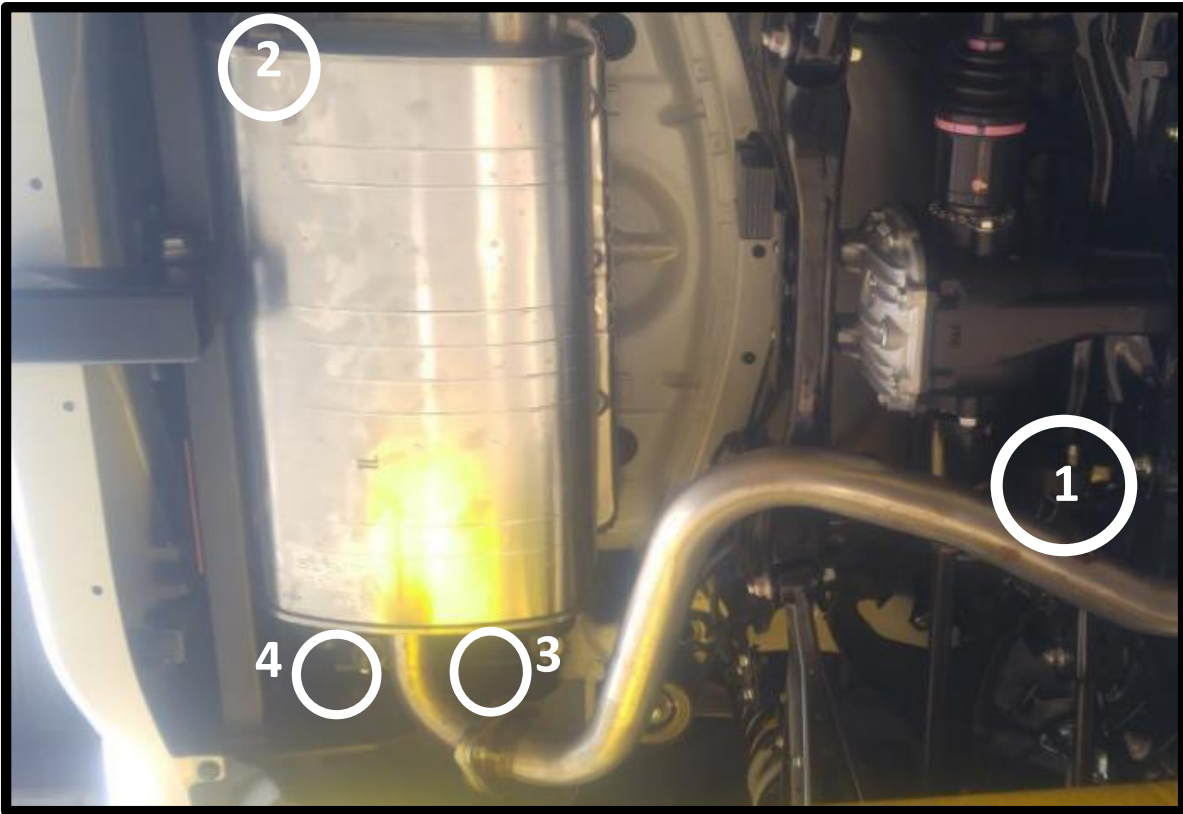

Figure 1.1



Figure 1.2

Step 2:

Locate the four holes in the frame rails on the underside of the vehicle (see figure 2.1). Remove the four rubber plugs from the driver's side and passenger side frame rails on underside of the vehicle.

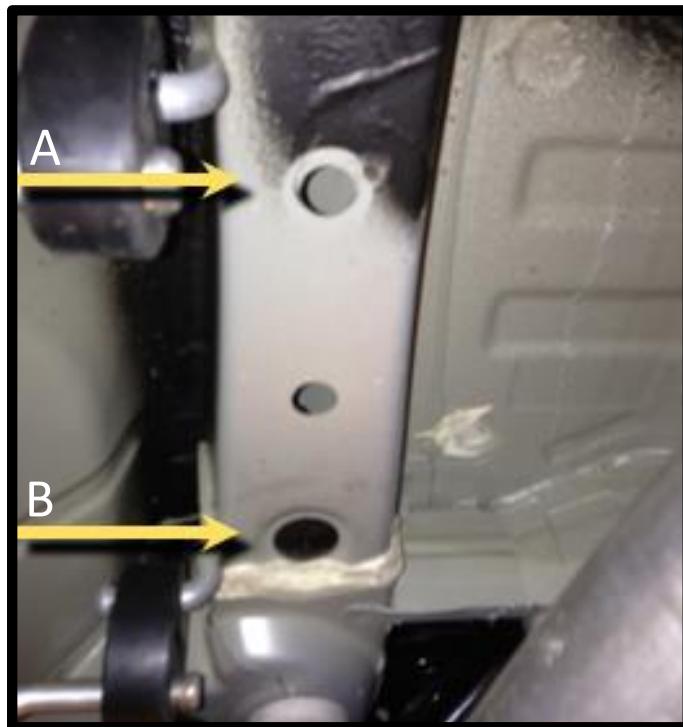

Figure 2.1

Step 3:

Guide the coiled end of the bolt fisher carefully into hole A and out through hole B as noted in Figure 2.1.

- Attach one plate washer, one internal lock washer, and one ½" x 2" - Hex Head bolt to the coiled end of the bolt fisher.
- Feed the hardware into the frame along the bolt fisher tail one piece at a time as shown in figure 4.1.
- Gently pull on the bolt fisher to guide hardware into position as seen in figure 4.2

Step 4:

For the forward most hole (hole B), take the bolt fisher and attach one ½" x 2" - Hex Head Bolt onto coiled end and push the hex head into hole B first.

- Once the Bolt is inside the frame feed one internal lock washer over the bolt fisher tail, followed by one plate washer.
- Pull the bolt back through the internal lock washer and plate washer towards hole B to complete the process. Repeat steps 3 & 4 as shown in figure 4.2 for passenger side holes. See Figure (4.1) & (4.2) for reference.



Figure 4.1



Figure (4.2) shows a successfully fished bolt with the 1/2"x2" bolt head resting on top of the 1/2" internal tooth star lock washer and plate washer, through the frame rail holes.

Step 5:

Raise the hitch into position being very careful not to push the hardware back into the frame.

- Once the hitch is in position on the bolts place two 1/2" flat washers, one 1/2" lock washer and one 1/2" hex nut onto each bolt.
- Pull the hitch toward the rear of the vehicle before tightening.
- Torque the four 1/2" hex nuts to 75 ft-lbs.

Figure 5.1 shows driver side installed correctly, and figure 5.2 shows passenger side installed correctly.

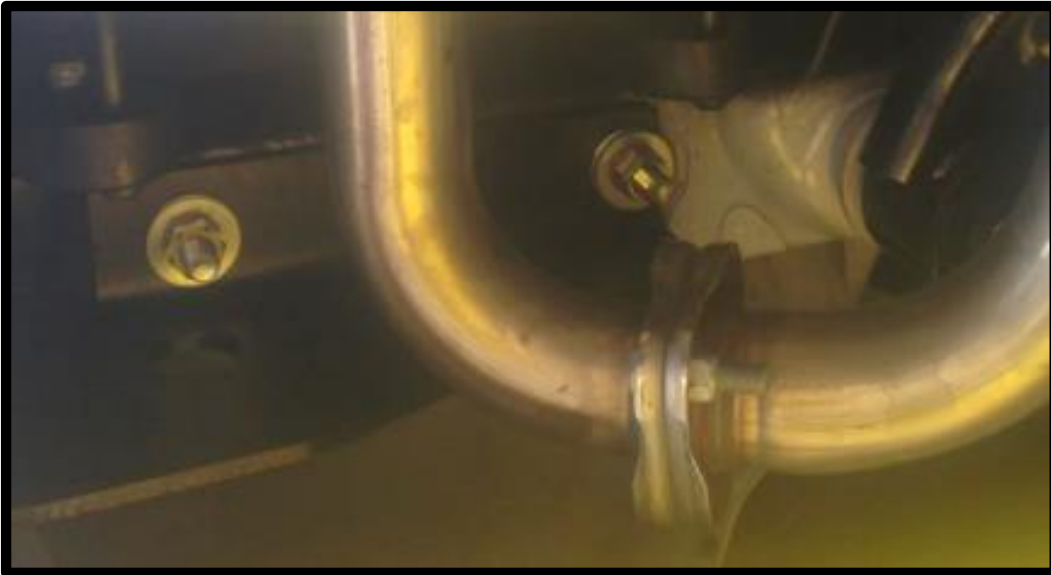

Figure 5.1

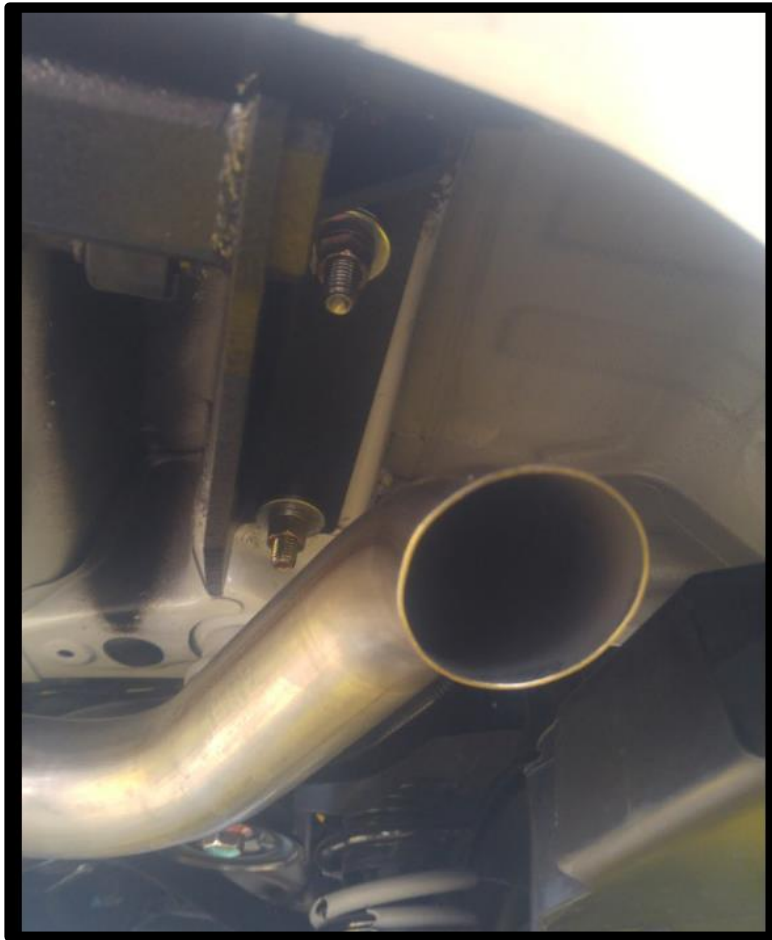

Figure 5.2

Step 6:

Raise the exhaust and re-attach all exhaust hangers. Re-lubricating the exhaust bungs will ease their reinstallation.

Step 7:

Insert your (2" or 1-1/4") Receiver into the Vertical Hitch Receiver as shown in Figure 7.1. Align the holes as shown in figure 8.1.

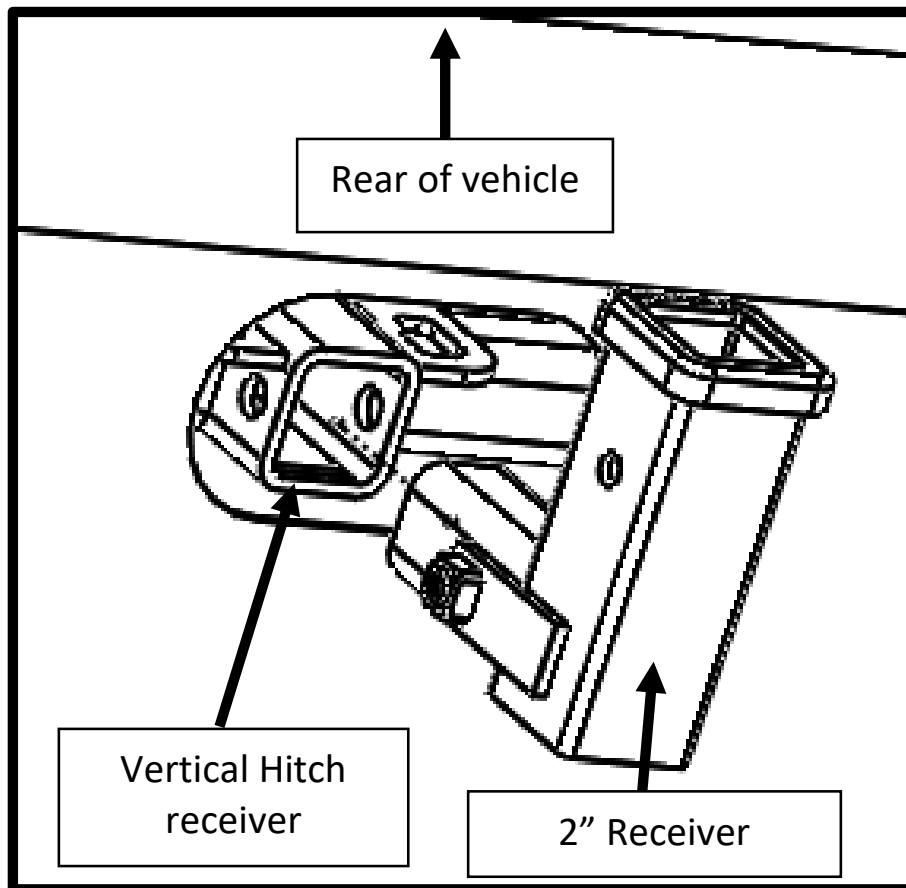

Figure 7.1 (2" Hitch Receiver Shown)

Step 8:

Insert the 5/8" hex bolt through the 5/8" lock washer and 5/8" flat washer. The Hitch Receiver holes should be aligned with the vertical hitch receiver. Push the hardware through the Vertical Hitch receiver and Receiver as shown in figure 8.1. Thread the bolt into the welded nut on the other side.

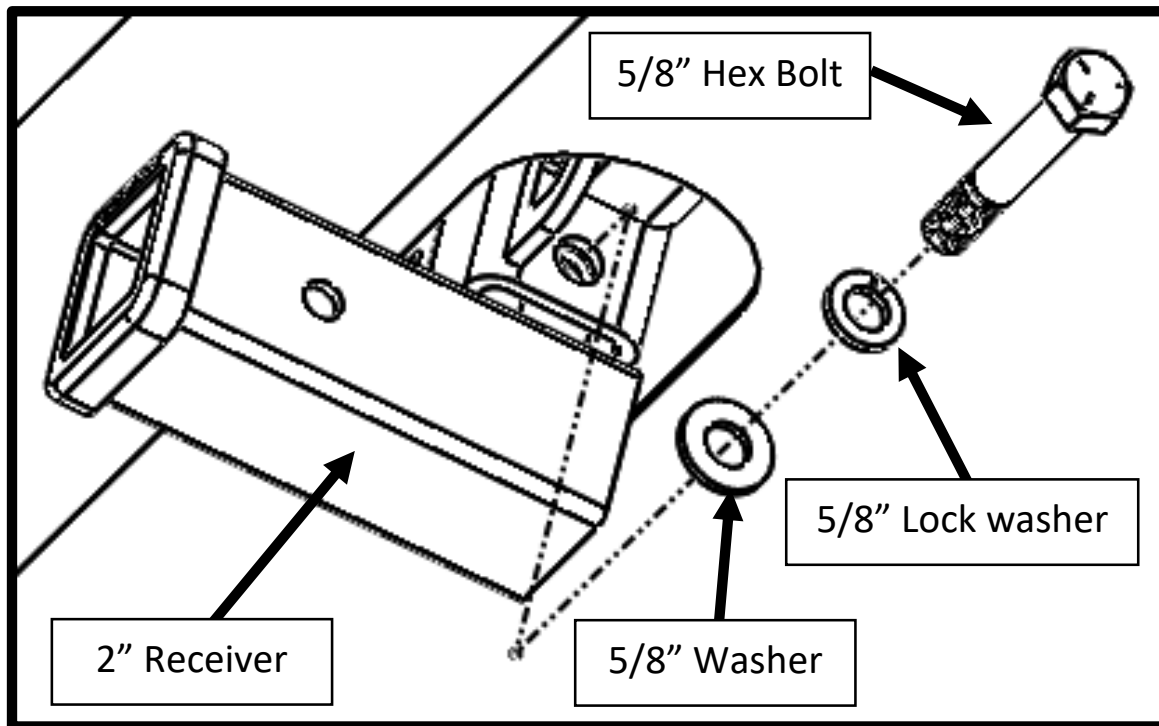

Figure 8.1 (2" Hitch Receiver Shown)

Step 9:

Torque the 5/8" Bolt to 112 lb-ft.

Step 10:

Congratulations you have successfully Installed your Eco Hitch!

WARRANTY/DISCLAIMER INFORMATION

Torklift Central requires proof of purchase for warranty claim registration, with pictures of any defective product before issuing a replacement. Torklift will not accept claims on any product without proof of purchase, which can be faxed, scanned, emailed or mailed to the information provided below. Torklift Central warrants its hitches, custom hitch receivers and accessories (excluding electrical wire harnesses which carry a warranty from their specified manufacturer) from date of purchase against defects in material and workmanship under normal use and service for the ownership life of the original consumer purchaser. Torklift Central will replace free of charge any part that proves defective in material or workmanship when presented to Torklift Central, transportation charges prepaid by purchaser, at the address below. **This warranty is limited to defective parts replacement only. Labor charges and/or damage incurred in installation or replacement, as well as incidental and consequential damages connected therewith are excluded.** This warranty does not include normal wear and tear or the finish and paint. Rusting, cracking or peeling of the finish is also excluded. Some states do not allow the exclusion or limitation of incidental or consequential damages, so the above limitation or exclusion may not apply to you. Any damage to Torklift Central products as a result of misuse, abuse, neglect, accident, improper installation or any use violative of instructions furnished by Torklift Central will void the warranty. This warranty gives you specific legal rights and you may also have rights, which vary from state to state. With warranty service, you may be able to go to a small claims court, a state court or a federal district court.

Although Torklift Central trailer hitches are both tested and rated for towing within the specific capacity label found on each trailer hitch.

Torklift Central assumes no liability for vehicle manufacturers warranty due to the use of a Torklift Central trailer hitch being used for towing behind any vehicle or using the trailer hitch in a manner that it was not designed for. Although this specific trailer hitch has a load rating, which includes trailer tongue weight, and a trailer weight carrying capacity, Torklift Central is not responsible for the voiding of any warranty on any vehicle due to factory towing limitations. All vehicle warranties are the sole property and responsibility of the owner of the vehicle that the Torklift Central trailer hitch is installed upon. Torklift Central does not endorse towing behind any vehicle if the vehicles manufacturer states that towing is not recommended. Check your vehicle's owner's manual for the proper tow rating of your vehicle.

ADDRESS: 315 Central Ave N. Kent, WA 98032

WARNING Your vehicle may have a lower tow rating than this trailer hitch. If your vehicle's tow rating is less than the rated towing capacity on your Torklift Central trailer hitch, your trailer hitch capacity is limited to your vehicle's factory rated towing capacity.

DANGER Never exceed your vehicle's manufacturer's recommended towing capacity which may be a lower rating than this trailer hitch