



Time Tested • Time Proven

855472-01 05/16

ROADMASTER, Inc. 6110 NE 127th Ave. Vancouver, WA 98682 800-669-9690 Fax 360-735-9300 www.roadmasterinc.com

035 and 035-1 tow bar adaptors

for all ROADMASTER motorhome-mounted tow bars

Installation Instructions

All specifications are subject to change without notice.

Purpose of this kit

This kit contains the components to connect ROADMASTER motorhome-mounted tow bars to the bumper mounts on off-road bumpers. Use the 035 adaptor for bumper mounts that are 3/4" thick; use the 035-1 adaptor for bumper mounts that are 1" thick.

WARNING

Read the instructions before installing the kit components. Failure to understand how to install this product could result in property damage, personal injury or even death.



WARNING

Confirm that the off-road bumper these components will be attached to has been approved by the bumper manu-

facturer for flat (all four wheels on the ground) towing. If the bumper is not approved for flat towing it may separate from the towed vehicle.

WARNING

Never use any component other than the frame as a connection point for the safety cables. Failure to do so may result in the loss of the towed vehicle. Refer to your tow bar owner's manual for complete instructions.

Required tools

1/4" Allen wrench 9/16" socket wrench

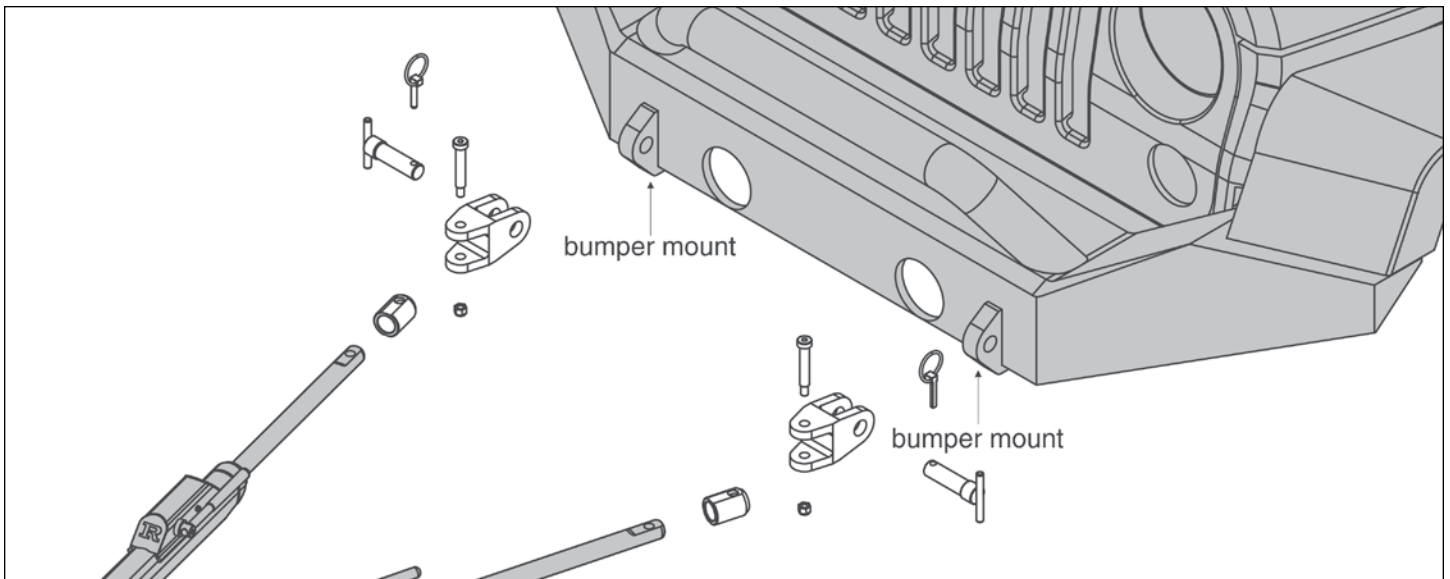

IMPORTANT NOTICE! Safety Definitions

These instructions contain information that is very important to know and understand. This information is provided for **safety** and to **prevent equipment problems**. To help recognize this information, observe the following symbols:

WARNING

WARNING indicates a potentially hazardous situation which, if not avoided, could result in property damage, serious personal injury or even death.

CAUTION

CAUTION indicates a potentially hazardous situation which, if not avoided, may result in property damage, or minor or moderate personal injury.

CAUTION

CAUTION used without the safety alert symbol indicates a potentially hazardous situation which, if not avoided, may result in property damage.

NOTE

Refers to important information and is placed in italic type. It is recommended that you take special notice of these items.

Installation instructions for...

- ...all Falcon 2 tow bars
- ...all Falcon All-Terrain tow bars
- ...BlackHawk 2 All-Terrain tow bars with serial numbers up to 16,500
- ...Sterling All-Terrain tow bars with serial numbers up to 14,500

1. Use a felt tip pen to mark one of the tow bar arms at the point where the round nut (Figure 1) attaches to the end of the tow bar inner arm (Figure 1).

2. With a 1/4" Allen wrench and a 9/16" socket wrench, remove the lock nut from the bottom of the Allen head shoulder bolt connecting the swivel ear to the round nut (Figure 2).

3. Remove the swivel ear. Discard the shoulder bolt, the washers and the lock nut.

Note: the swivel ear will not be used in this application. However, it should be saved in case the tow bar is ever used to tow other vehicles.

4. Using the replacement shoulder bolt, nylon washers and nylon lock nut, attach the original round nut (and the tow bar) to the tow bar adaptor (Figure 3).

Make certain that the round nut has not moved forward or backward from the position you marked in step 1. If the round nut has moved forward, the replacement shoulder bolt will not fit. If the round nut has moved backward, the round nut will rotate off the tow bar arm. See Figure 4.

WARNING

If the round nut is moved backward on the tow bar arm, the shoulder bolt will not hold the round nut in place. Towing vibrations will cause the round nut to rotate off the tow bar arm.

The tow bar arm will detach from the towed vehicle, causing the towed vehicle to separate or to be held by only one tow bar arm.

5. Repeat steps 1 through 4 for the other tow bar arm.

6. Attach both adaptors to the bumper mounts with the included hitch pins and linch pins, as shown on page one.

Note: if the diameter of the bumper mounts is 1", use the included hitch pin sleeves (shown to the right). If the diameter of the bumper mounts is 7/8", the sleeves are not used.

7. Read the tow bar owner's manual and follow all connection, maintenance and safety information.

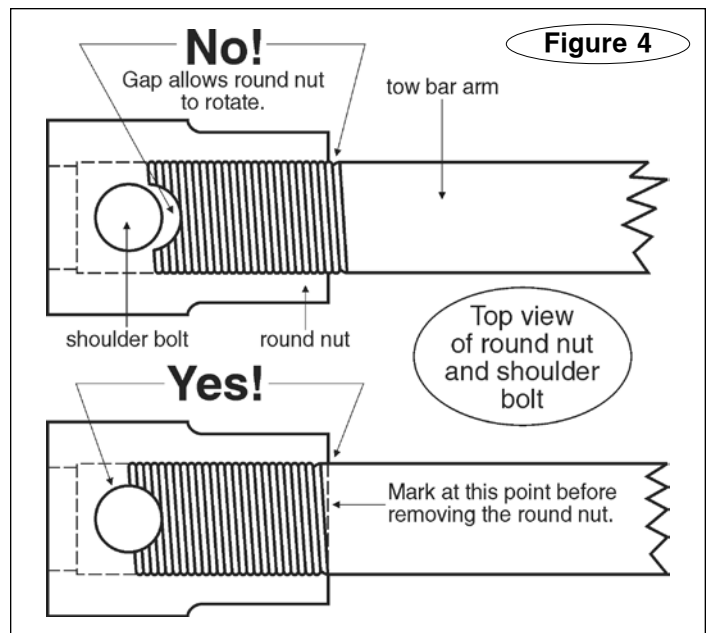
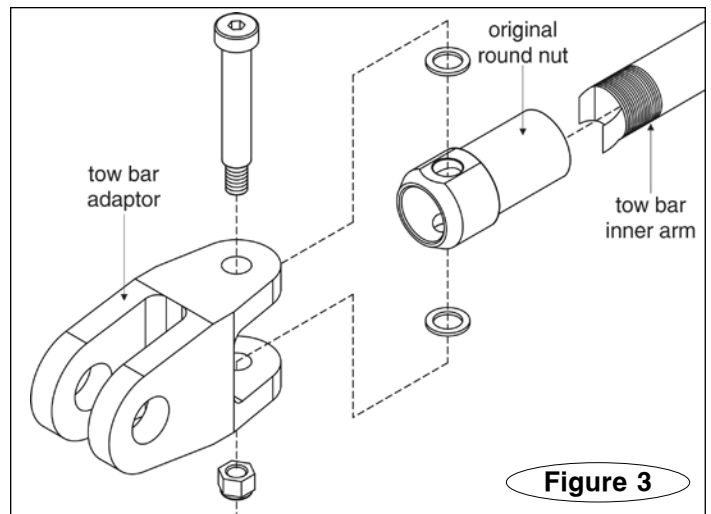
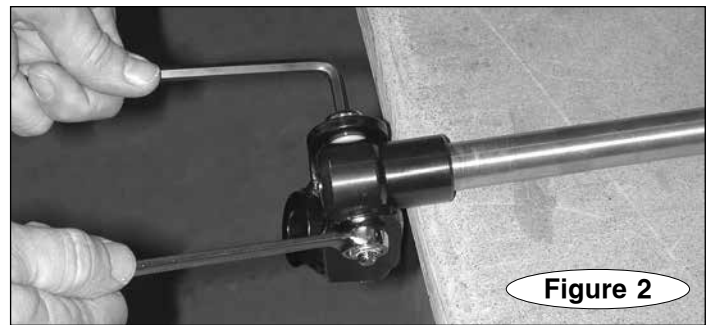
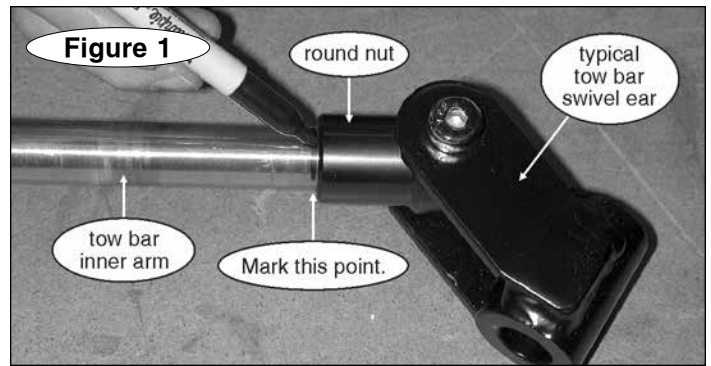
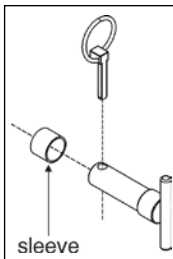

Installation instructions for...

- ...Sterling All-Terrain tow bars with serial numbers of 14,501 and above
- ...BlackHawk 2 All-Terrain tow bars with serial numbers above 16,500

1. With a 1/4" Allen wrench and a 9/16" socket wrench, remove the lock nut from the bottom of the Allen head shoulder bolt connecting the swivel ear to the inner arm (Figure 1).

2. Remove the shoulder bolt, washers, lock nut and swivel ear.

Note: discard the shoulder bolt, the washers and the lock nut. The swivel ear will not be used in this application. However, it should be saved in case the tow bar is ever used to tow other vehicles.

3. Position the round nut adaptor (Figure 3) at the end of the tow bar inner arm.

4. Using the replacement shoulder bolt, nylon washers and nylon lock nut, attach the round nut adaptor to the tow bar adaptor (Figure 2).

5. Repeat steps 1 through 4 for the other tow bar arm.

6. Attach both adaptors to the bumper mounts with the included hitch pins and linch pins, as shown on page one.

Note: if the diameter of the bumper mounts is 1", use the included hitch pin sleeves (shown to the right). If the diameter of the bumper mounts is 7/8", the sleeves are not used.

7. Read the tow bar owner's manual and follow all connection, maintenance and safety information.

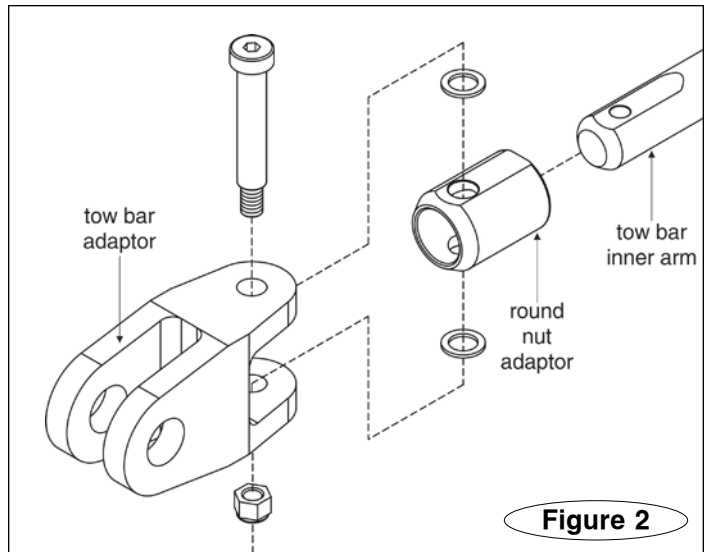
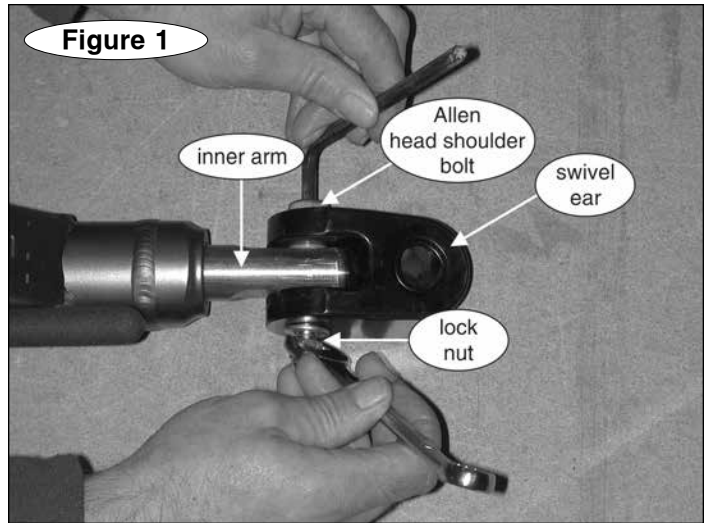
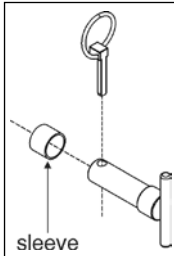

035 and 035-1 adaptor parts

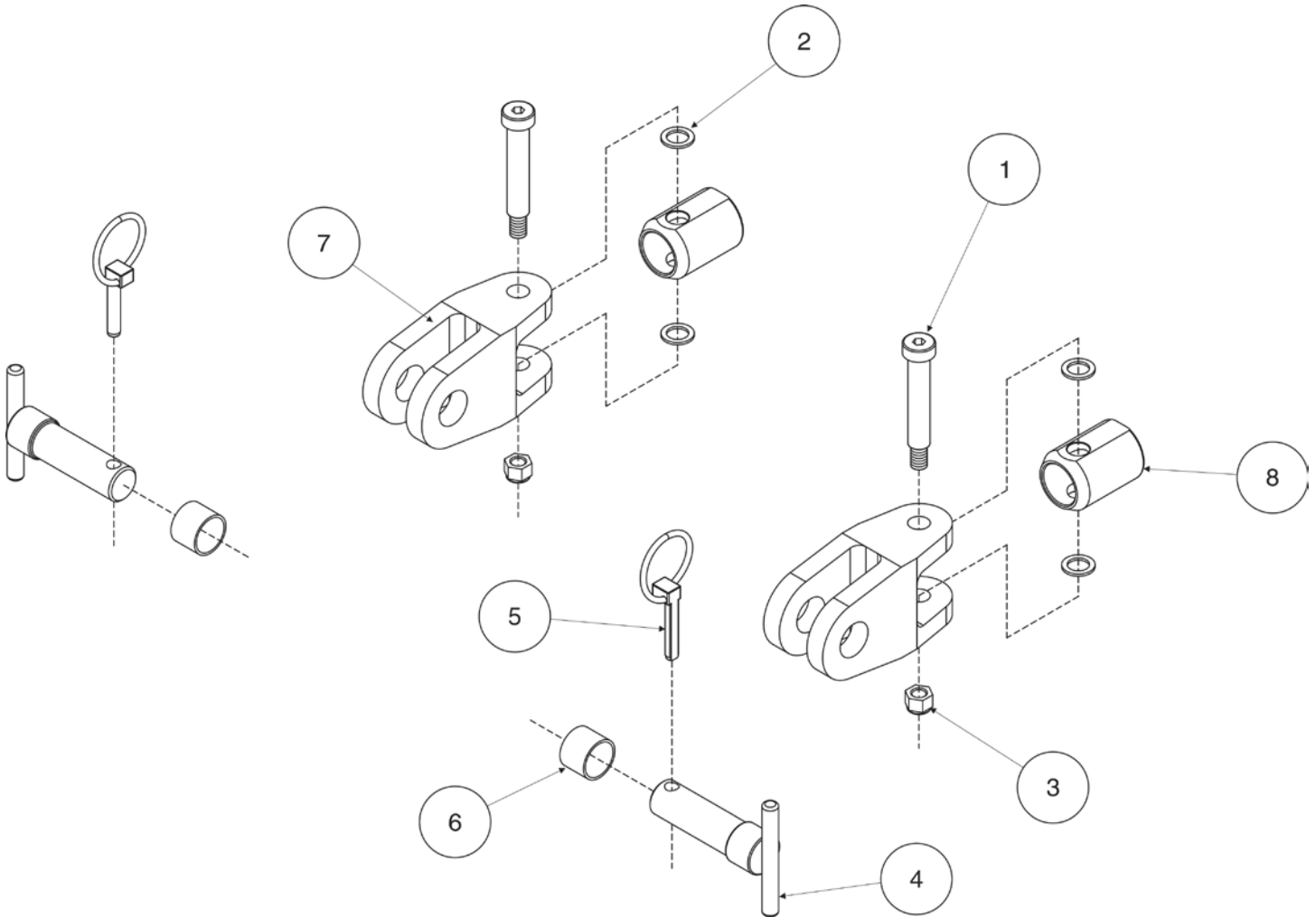

Item	Quantity	Part Number	Description
1	2	350376-20	½" x 2½" shoulder bolt
2	4	350356-00	nylon washer
3	2	350255-00	3/8" nylon lock nut
4	2	910044	hitch pin
5	2	357000-00	linch pin
6	2	A-005020	035 sleeve
	2	A-005116	035-1 sleeve
7	2	A-005019	035 tow bar adaptor
	2	A-005097	035-1 tow bar adaptor
8	2	A-001818	round nut adaptor