

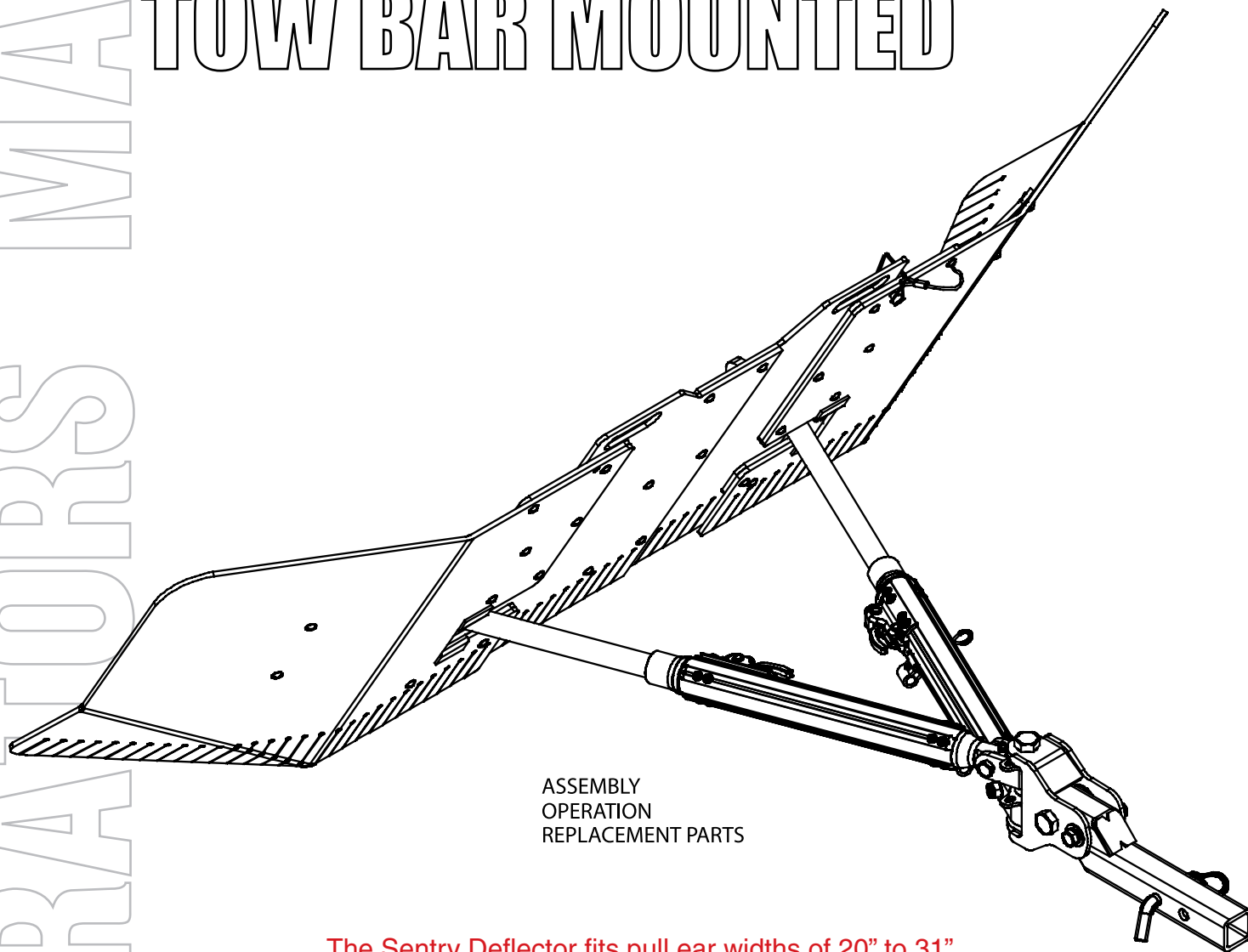

Demco

Sentry Deflector TOW BAR MOUNTED



ASSEMBLY
OPERATION
REPLACEMENT PARTS

The Sentry Deflector fits pull ear widths of 20" to 31"

Demco

4010 320th St., P.O. BOX 189, BOYDEN, IA. 51234
PH: (712) 725-2311
FAX: (712) 725-2380 or 1-800-845-6420
TOLL FREE: 1-800-54DEMCO (1-800-543-3626)
www.demco-products.com

READ *complete manual CAREFULLY
BEFORE attempting operation.*

Doing Our Best to Provide You the Best

OPERATORS MANUAL

Introduction

Thank you for purchasing a Demco Sentry deflector. We feel you have made a wise choice and hope you are completely satisfied with your new tow bar.

GENERAL INFORMATION

1. Whenever terms “**LEFT**” and “**RIGHT**” are used in this manual it means from a position behind tow unit and facing forward.
2. When placing a parts order, refer to this manual for proper part numbers and place order by **PART NO. and DESCRIPTION.**



Warning

Safety is of utmost importance at all times. There are several items that must be checked each time before using and while using a tow bar with Sentry deflector.

Before allowing anyone to hook up or operate a tow bar, be sure they have read and understand the proper operating procedure.

DO NOT use worn or damaged cables and/or pins.

Be sure the **SAFETY CABLES** are hooked, chassis to chassis, to both the towing and towed vehicles using the crisscross method.

Check clearance between vehicles and deflector in a turning situation.

Check base plate mounting bolts for tightness and frame for metal fatigue.

Keep fingers away from pivot points to prevent personal injury.

Be sure the steering components of the towed vehicle are properly aligned.

NOTE: This unit can be backed up with deflector in moderate increments. Any severe backwards cornering could result in damage to the Tow Bar and/or towed vehicle chassis.

Check to make sure that all lights are in proper working order.

Make sure Sentry deflector is locked down and safety pin installed before towing.

Make sure tow bar is latched before towing vehicle. Damage may occur to tow bar and connecting clevis.

ASSEMBLY INSTRUCTIONS

1. Remove connecting clevis from Excali-bar, Aluminator, or Kwik-Tow.



2. Install new Sentry connecting clevis, using new washers, 1/2" bolts, and locknuts. **Note:** Excali-bar, and Aluminator use gray (thick) washers inside of clevis. Kwik-Tow uses white (thin) washers. Tighten 1/2" bolt so that there is a slight drag when pivoting clevis side to side. **Note:** On Kwik-Tow, long leg of clevis goes on top side of tube.

3. Attach tow bar to towed vehicle and latch rear connecting legs by backing towed vehicle. Long end of Sentry connecting clevis must be on top. If not, unlatch rear connecting leg and rotate shaft, reattach.

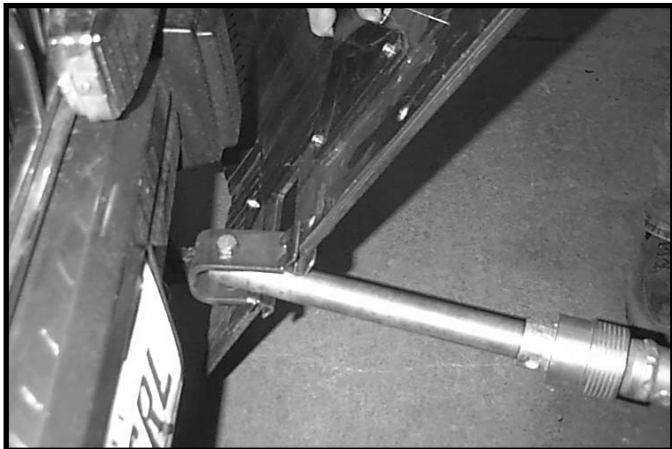

4. Slide right and left wings into Sentry connecting clevis until wings are approximately 1/4" away from bottoming out against clevis.

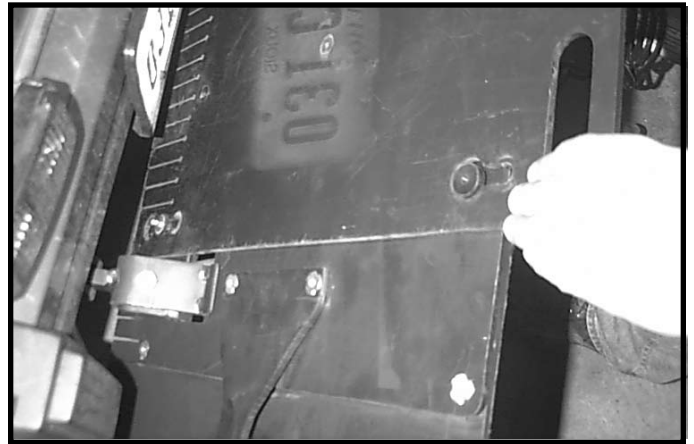

5. Slide one side of center section on left wing and the other center on the right wing and push down to latch in key slots.



6. Clamp center section together at top when they are even at top and gap at clevis is 1/4" from bottoming out on each side.

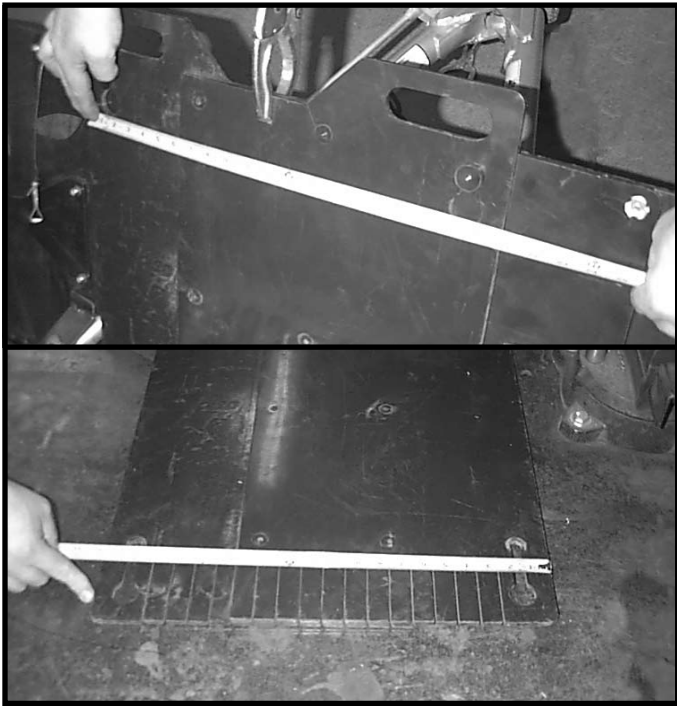

7. Measure the top outside distance of center sections as a unit. Take center section out, lay it on a flat surface and measure the bottom of center section. The bottom should measure the same as the top. Move bottom until it measures the same, making sure the top is still even or flush and clamp into place.

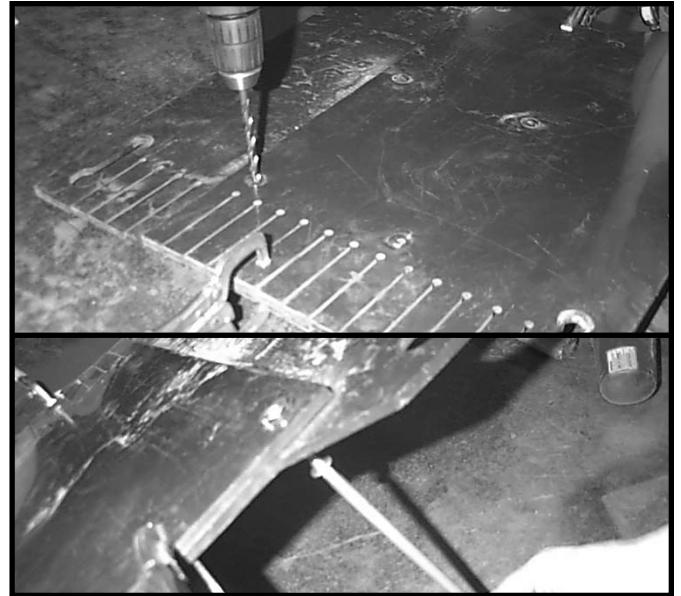

8. Drill six holes through center section with a 9/32" drill bit, (On wider setting, it may require three holes) using existing holes as a template to drill through. Install tee nuts and truss head bolts in these holes and remove clamps. Apply thread lock to the threads.

MOUNTING INSTRUCTIONS

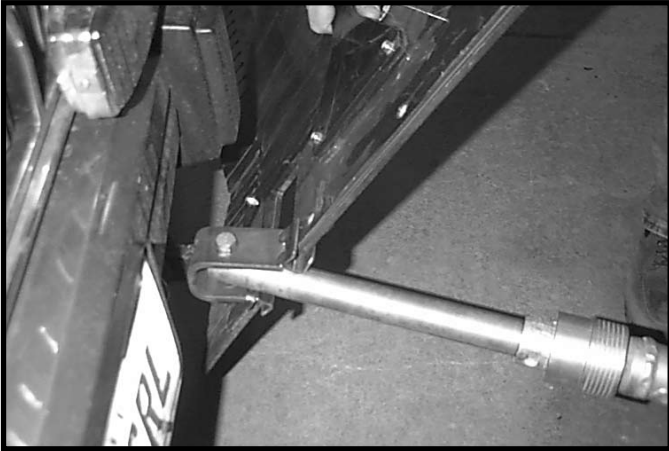

1. Slide right and left wings into Sentry connecting clevis until wings are approximately 1/4" away from bottoming out against clevis.

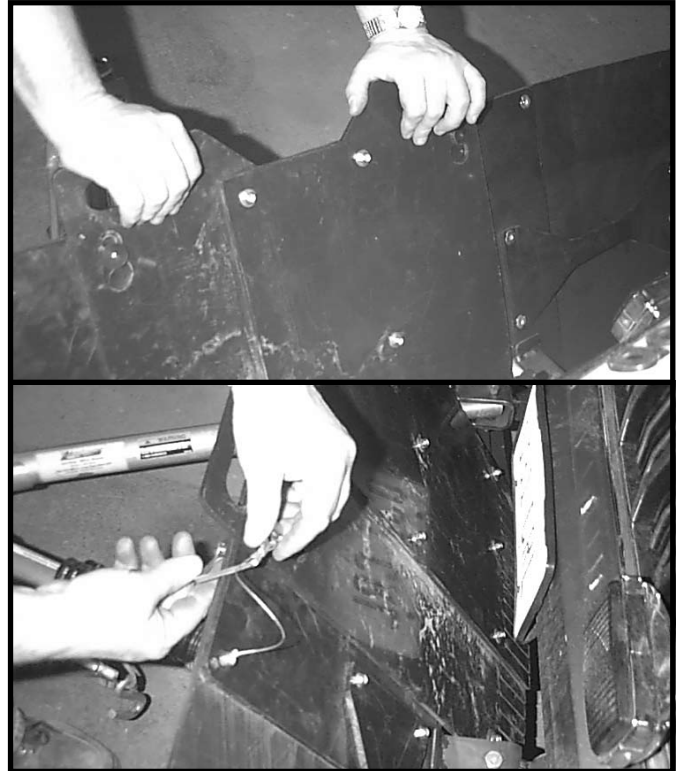

3. Push down on center section until it snaps into place. Insert pin through hole provided and snap wire over pin to secure Sentry together as a unit. Hole on other side maybe used for a paddle lock for antitheft, if necessary.



2. Install center section's lower key holes over the bottom clamps of wings first, both the same time. Slowly push down until top key slots start to line up. Assist line up by moving each wing up or down. When all clamps are through key holes.



4. Due to different locations of wiring hook ups, and safety cable hook points, it maybe necessary to drill hole or holes through Sentry for pass through. Here is an example of a 2" hole saw used to allow the 6-wire electrical cable to pass through. Safety cables can pass through clevis area most of the time for hookup to vehicle.

Remember, before towing vehicle, make sure tow bar is latched by backing towed vehicle. Damage may result to tow bar and Sentry clevis if tow bar is NOT latched before towing.

SENTRY(9523025) PARTS BREAKDOWN

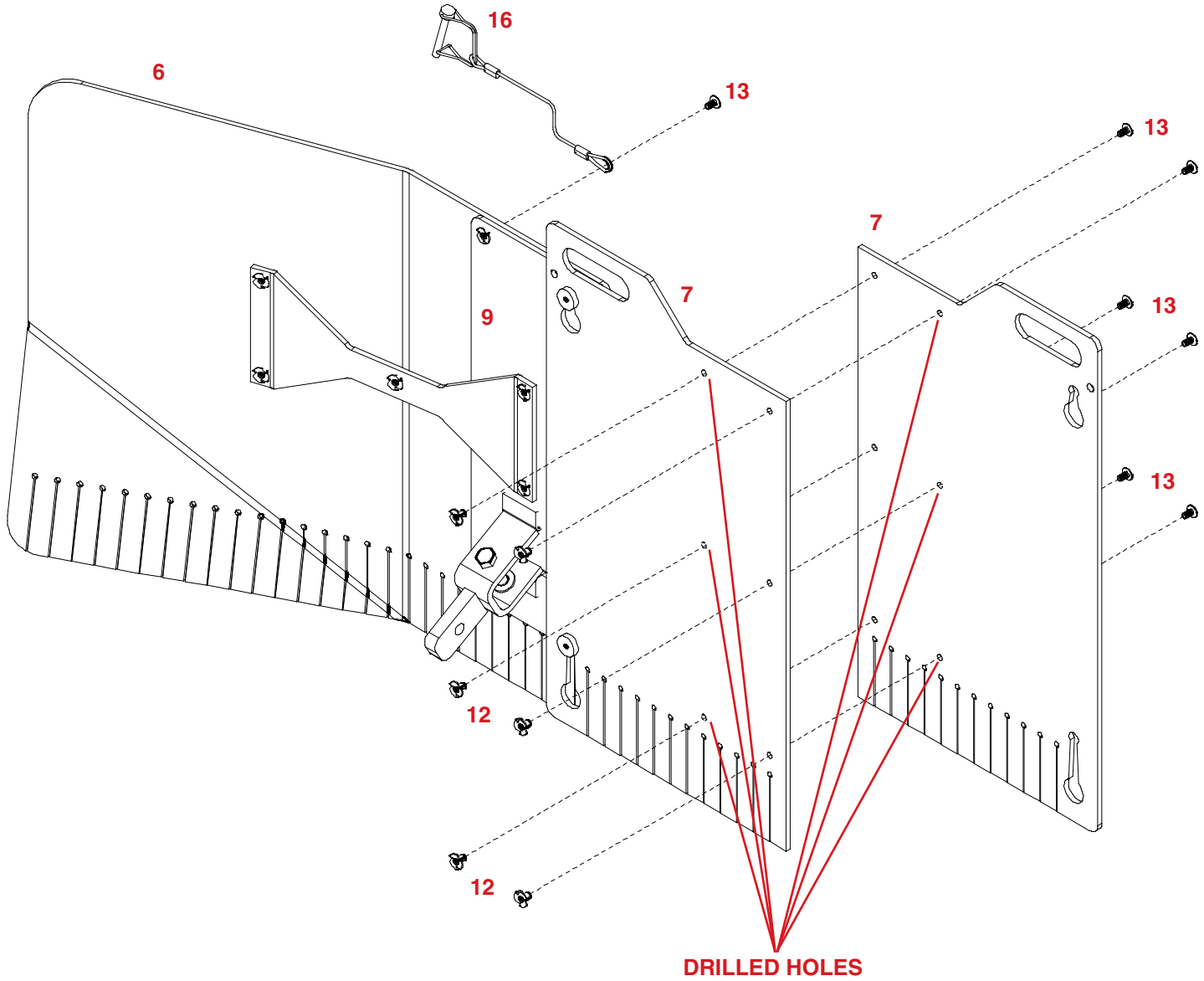

STANDARD BRACKET WITH DEMCO SENTRY DEFLECTOR

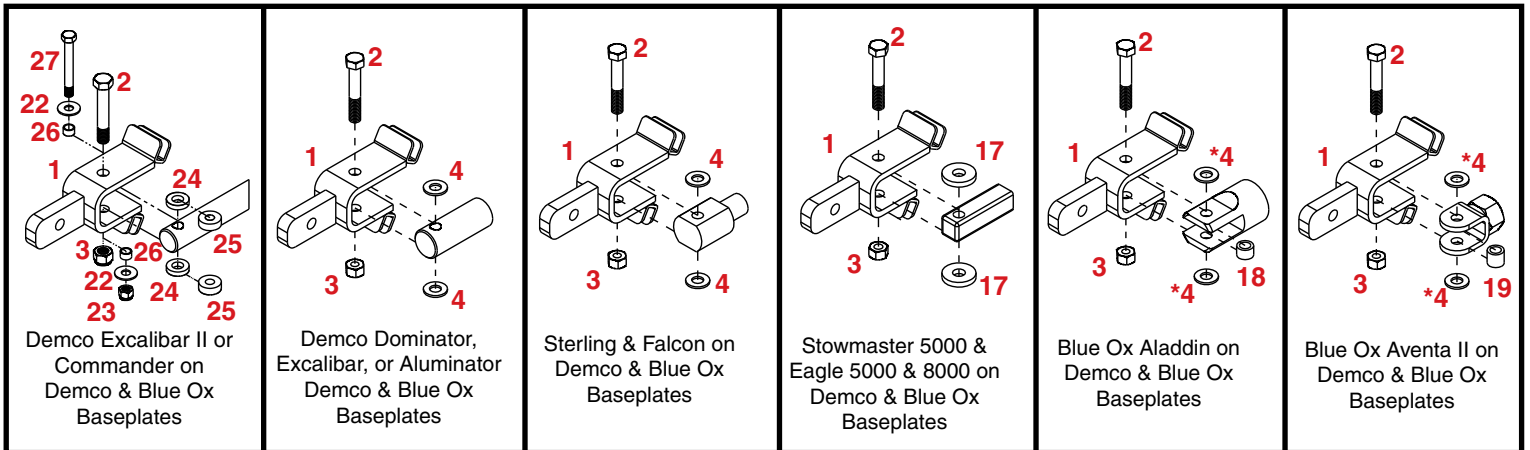

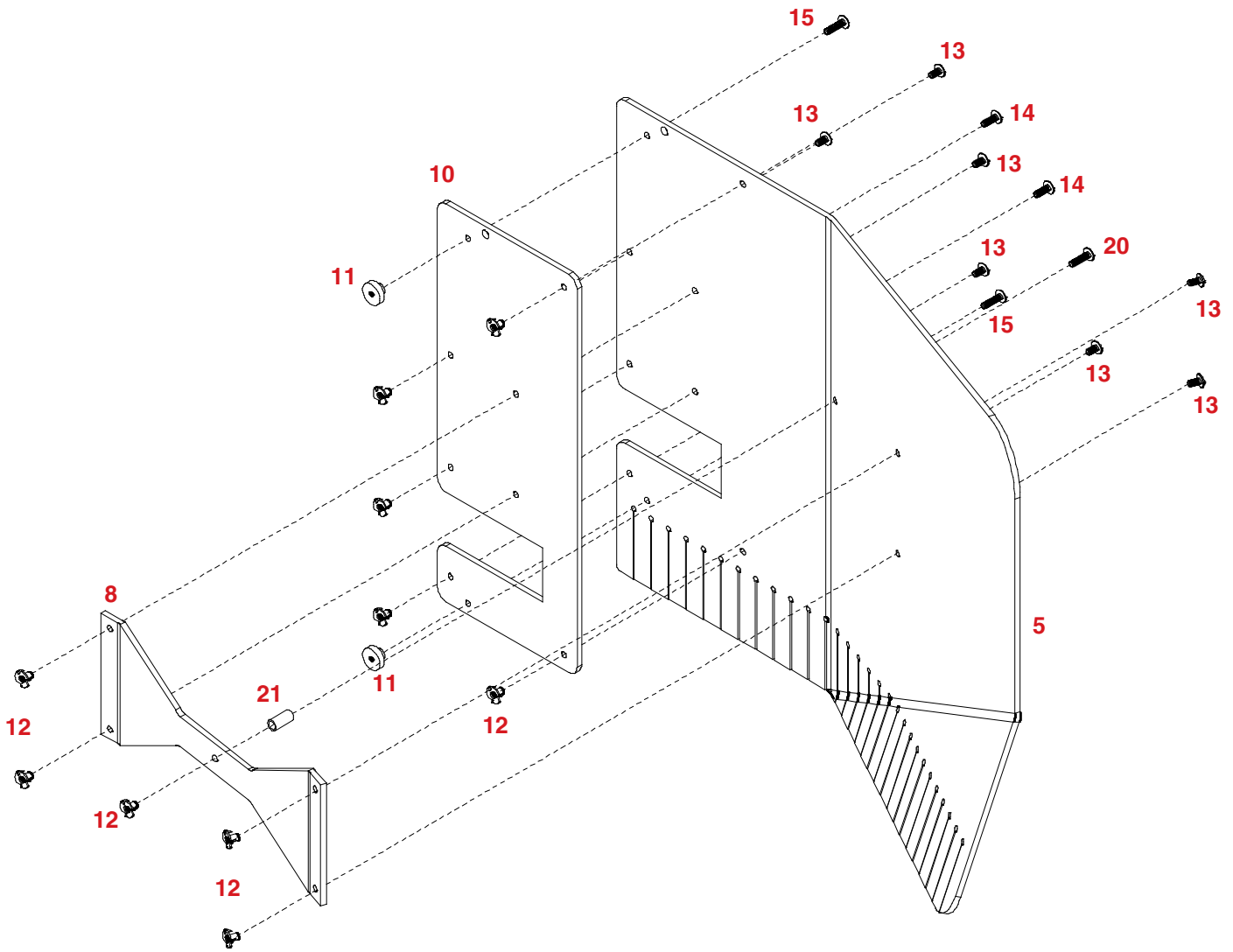

SENTRY (9523025) PARTS LIST

REF. NO.	PART NO.	QTY.	DESCRIPTION	REF. NO.	PART NO.	QTY.	DESCRIPTION
1.	10138-81	2	Sentry Mounting Clevis	15.	10185	4	1/4"-NC x 1" Phillips Truss Bolt
2.	07164-95	2	1/2" x 3" Bolt	16.	05337	1	Safety Lock Pin with Cable
3.	02178	2	1/2" Nylon Lock Nut	17.	07908-95	4	Heavy Washer
4.	03809	4	Wear Bushing, Excali-Bar & Aluminator	18.	02875-95	2	Bushing 7/8" Long
*4.	07699	4	Wear Bushing, Kwik-Tow	19.	00698-95	2	Bushing 1" Long
5.	10132	1	Right Wing Deflector	20.	11264	2	1/4"-NC x 1-1/2" Phillips Truss Bolt
6.	10131	1	Left Wing Deflector	21.	11265	2	Bushing, 1" OD x 3/8" ID x 1"
7.	10133	2	Center Deflector	22.	00059	4	3/8" Flat Washer
8.	10135	2	Brace/Handle	23.	02592	2	3/8" Nylon Lock Nut
9.	10134	1	Left Mounting Plate	24.	13666	4	Clevis Spacer f/ Excalibar II
10.	10775	1	Right Mounting Plate	25.	13667	4	Clevis Spacer f/ Commander
11.	10136	4	Retainer Button	26.	13668	4	Bushing f/ 3/8" Commander Bolt
12.	10186	26	1/4" T-Nut	27.	13669-95	2	Clevis Bolt f/ Commander
13.	10183	20	1/4"-NC x 1/2" Phillips Truss Bolt	-	10297	1	Storage Bag
14.	10184	4	1/4"-NC x 3/4" Phillips Truss Bolt	-	12329	1	Thread Lock (not shown)

SENTRY ADAPTER KIT (9523027) FOR ROADMASTER MX & MS BASEPLATES

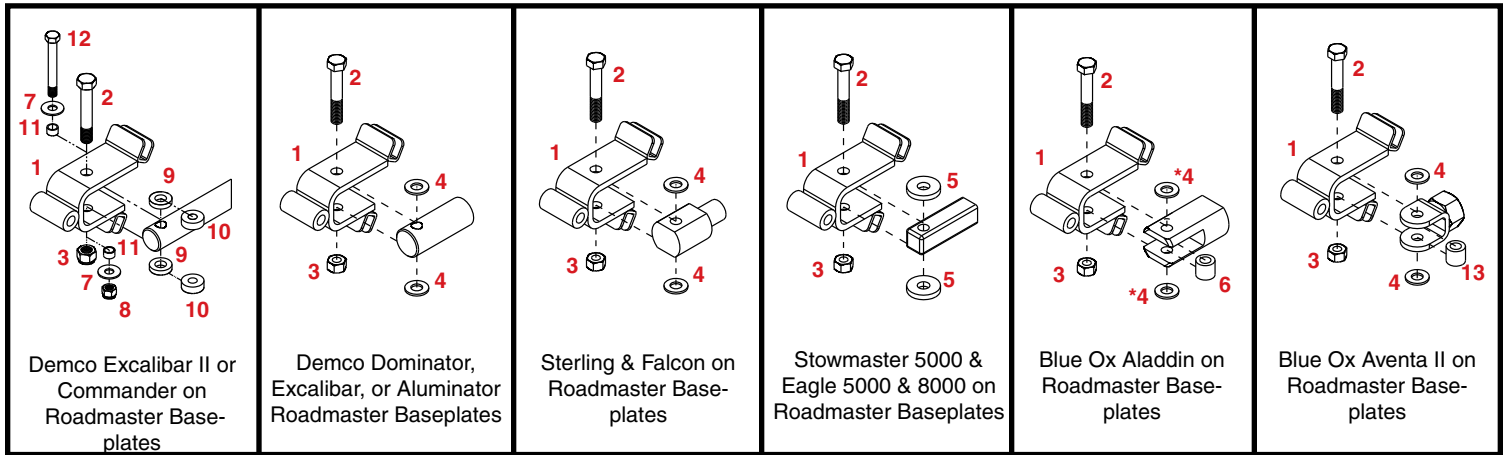

SENTRY ADAPTER KIT (9523027) PARTS LIST

REF. NO.	PART NO.	QTY.	DESCRIPTION
1.	10282-81	2	Sentry Mounting Clevis
2.	07164-95	2	1/2" x 3" Bolt
3.	02178	2	1/2" Nylon Lock Nut
4.	03809	4	Wear Washer Bushing (Thick)
*4.	07699	4	Wear Washer Bushing (Thin)
5.	07908-95	4	Heavy Washer
6.	10704-95	2	Bushing 1"OD x 7/8" Long

REF. NO.	PART NO.	QTY.	DESCRIPTION
7.	00059	4	3/8" Flat Washer
8.	02592	2	3/8" Nylon Lock Nut
9.	13666	4	Clevis Spacer f/ Excalibar II
10.	13667	4	Clevis Spacer f/ Commander
11.	13668	4	Bushing f/ 3/8" Commander Bolt
12.	13669-95	2	Clevis Bolt f/ Commander
13.	00698-95	2	Bushing 1" Long

Please order replacement parts by PART NO. and DESCRIPTION.

SENTRY ADAPTER KIT (9523061) FOR BLUE OX BASEPLATES

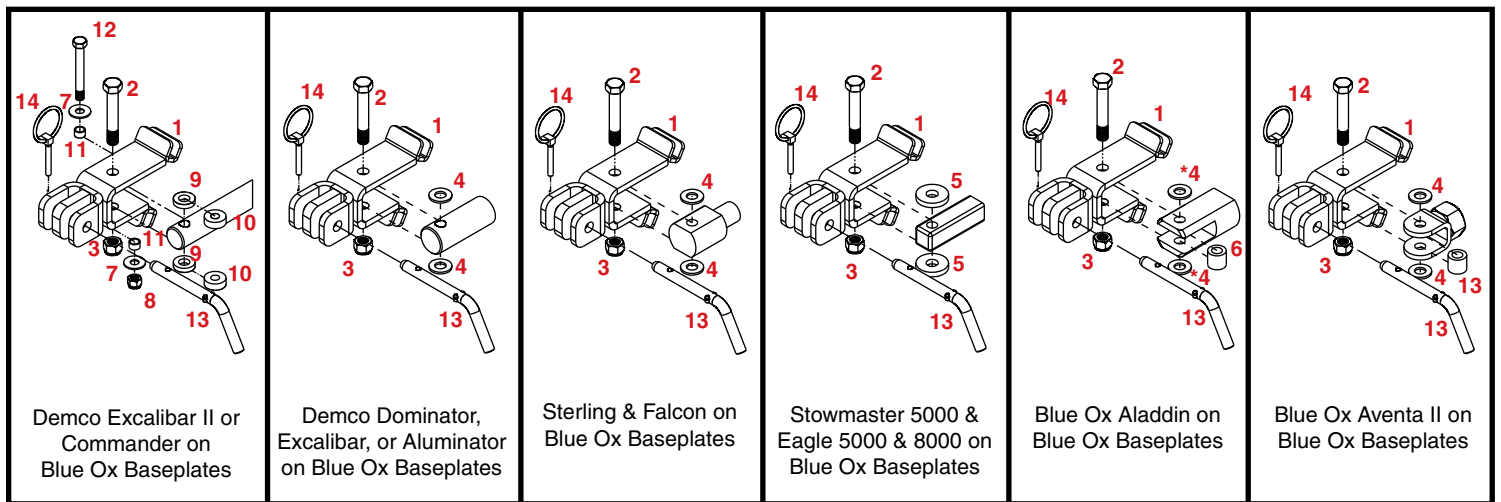

SENTRY ADAPTER KIT (9523061) PARTS LIST

REF. NO.	PART NO.	QTY.	DESCRIPTION
1.	13728-81	2	Sentry Mounting Clevis f/Blue Ox
2.	07164-95	2	1/2" x 3" Bolt
3.	02178	2	1/2" Nylon Lock Nut
4.	03809	4	Wear Washer Bushing (Thick)
*4.	07699	4	Wear Washer Bushing (Thin)
5.	07908-95	4	Heavy Washer
6.	10704-95	2	Bushing 1"OD x 7/8" Long
7.	00059	4	3/8" Flat Washer

REF. NO.	PART NO.	QTY.	DESCRIPTION
8.	02592	2	3/8" Nylon Lock Nut
9.	13666	4	Clevis Spacer f/ Excalibar II
10.	13667	4	Clevis Spacer f/ Commander
11.	13668	4	Bushing f/ 3/8" Commander Bolt
12.	13669-95	2	Clevis Bolt f/ Commander
13.	13496-95	2	Attaching Pin
14.	02397	2	Lynch Pin
15.	00698-95	2	Bushing 1" Long

Please order replacement parts by PART NO. and DESCRIPTION.