



C-45 SUBKIT

DODGE RAM 2500/3500

WARNING!! BRAKE, FUEL, AND ELECTRICAL LINES MAY NEED TO BE LOOSENED OR REPOSITIONED TO PROVIDE CLEARANCE FOR NEW HARDWARE.
ALL MODELS REQUIRE MODIFICATION OR REMOVAL OF HEAT SHIELDS

INSTALLATION STEPS

****REMOVE SPARE TIRE FOR INSTALLATION****

- 1) Install the cross arms by inserting them between the shock and spring. **(See figure 1.)** Slide leading end into the gap between truck bed and frame on the passenger side. Swing the other end into the gap between truck bed and frame on the driver's side. **(Note: Holes in the cross arms must face each other as shown in Figure 1.)**
- 2) Remove emergency brake cable hanger from the driver's side frame rail. Hang side plates from the 5/8" welded studs which extend from the cross arms. Fasten each plate with two 5/8" flange nuts provided. Finger tight only.
- 3) Use an 1 1/2" hole saw to drill an access hole through the bottom of the truck frame. Drill hole above rear axle and just behind the rubber stops mounted to the bottom of the frame. Drill hole on both sides of vehicle as shown in **Figure 2**.
- 4) Fishwire 5/8" carriage bolts and spacers through the previously drilled access holes. Pull carriage bolt threads out existing frame hole toward the front of truck, each side. Place a 5/8" washer between side plate and frame when pulling fishwire out through the side plates as shown in **Figure 2**. Secure the plate in place with a 5/8" flange nut. Finger tight only.
- 5) Rotate cross arms until they contact the truck bed. Push the rear of side plates up tight and level to the truck bed. Clamp the side plates to the frame. **(Note: Do not drill remaining side plate mounting holes at this time.)**
- 6) Center the rear cross arm studs in the side plate slots as shown in **Figure 3**. Use a 15/16" wrench to tighten the 5/8" flange nuts, on rear cross arm, to the side plates. **(Note: Do not tighten front cross arm until center section installation is complete.)**
- 7) With side plates clamped and rear cross arm secure, position the drilling template provided between the cross arms as shown in **Figure 2**. Attach the template to the cross arms using four 5/8" carriage bolts and flange nuts provided with the center section. Tighten the 5/8" flange nuts with a 15/16" socket. **(Note: Template must be positioned correctly based on application shown in Figure 2.)**
- 8) **Be sure the cross arms are vertical to the truck bed before drilling!** Drill a 1/4" hole into the truck bed using the guide hole in the center of the template. Remove the template from the cross arms after the pilot hole has been drilled.

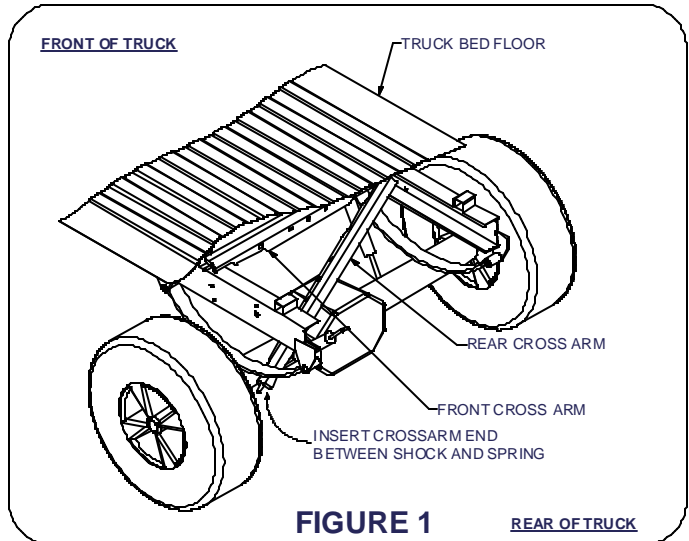

FIGURE 1

REAR OF TRUCK

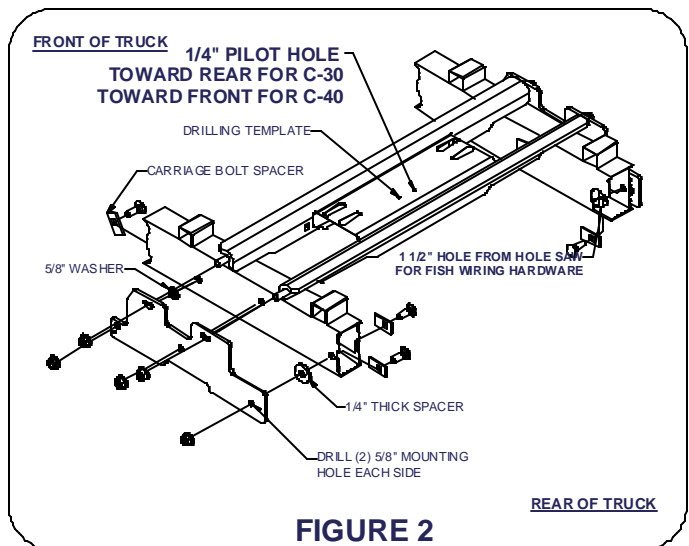

FIGURE 2

REAR OF TRUCK

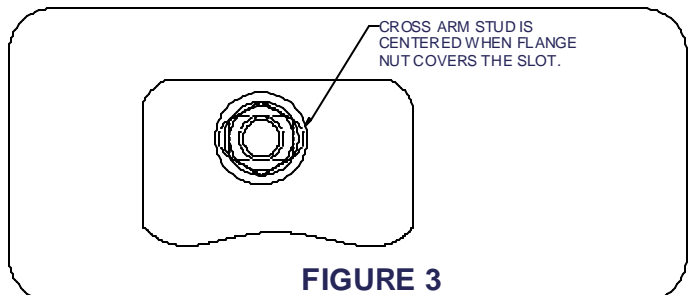

FIGURE 3

Curt Manufacturing Inc., warrants this product to be free of defects in material or workmanship at the time of retail purchase by the original purchaser. If the product is found to be defective, Curt Manufacturing Inc., may repair or replace the product, at their option, when the product is returned, prepaid, with proof of purchase. Alteration to, misuse of, or improper installation of this product voids the warrant. Curt Manufacturing Inc.'s liability is limited to repair or replacement of products found to be defective, and specifically excludes liability for incidental or consequential loss or damage.



C-45 SUBKIT

DODGE RAM 2500/3500

INSTALLATION STEPS CONT.

- 9) From inside the truck bed, position the drilling template as it was under the vehicle in step 9. **(See Figure 4.)** To hold template position, place a 1/4" bolt through the template and the new hole in the bed. Use a tape measure to square the drilling template by measuring from the tail gate end of bed to the template. Using a 5/8" drill bit, drill the center of each slotted hole in template. **(Note: Be sure the holes are drilled in the lower rib sections of the truck bed as shown in Figure 5.)**
- 10) From inside the truck bed use a 3 5/8" hole saw to drill through the bed. Use the previously drilled 1/4" hole as a guide. Use a file to deburr any sharp edges.
- 11) At this time, follow the "Quick Goose" instructions for installation of the center section and return when completed.
- 12) With center section installation complete, the final side plate mounting holes can be drilled. Use holes in side plate as a guide to drill a 1 1/16" hole through the frame at both locations. **(See Figure 2 on page 1.)**
- 13) Fishwire the remaining 5/8" carriage bolts and spacer through access hole and out the hole drilled in step 12.
- 14) Torque the 5/8" hardware to 150 lb.-ft. Re-attach fuel, brake, and electrical lines that may have been loosened or removed during installation.

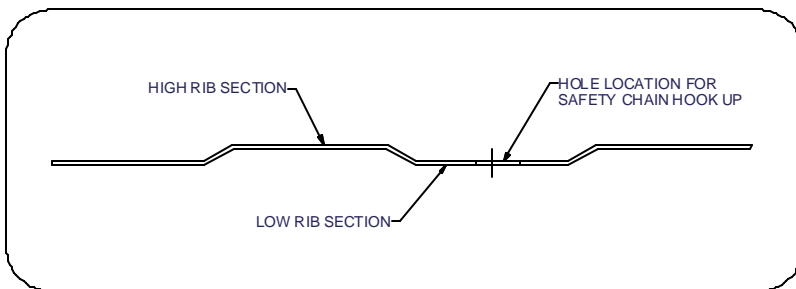
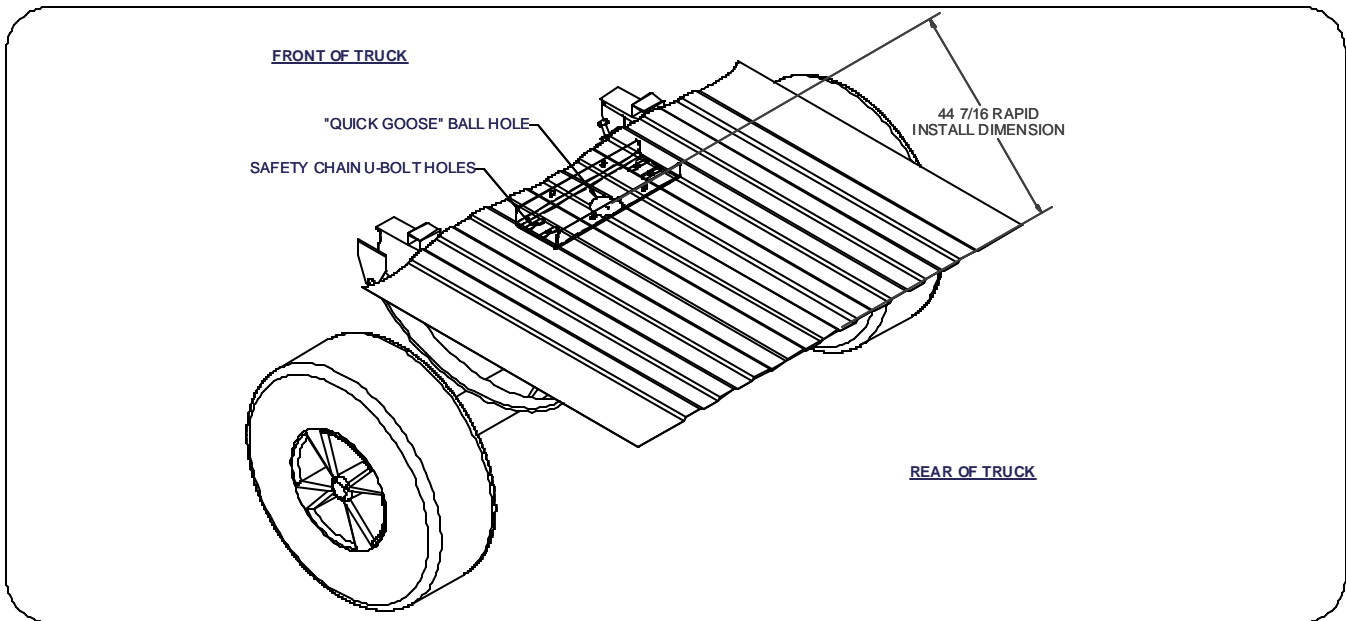

PARTS LIST

- (6) 5/8-11 x 2" Carriage Bolt**
- (10) 5/8-11 Flange Nut**
- (2) 5/8" Washers**
- (6) Installation Spacer (CM-SP9)**
- (2) Installation Spacer (CM-SP47)**
- (1) 5/8" Fishwire Tool**
- (1) Installation Template (CM-308-2)**

Curt Manufacturing Inc., warrants this product to be free of defects in material or workmanship at the time of retail purchase by the original purchaser. If the product is found to be defective, Curt Manufacturing Inc., may repair or replace the product, at their option, when the product is returned, prepaid, with proof of purchase. Alteration to, misuse of, or improper installation of this product voids the warrant. Curt Manufacturing Inc.'s liability is limited to repair or replacement of products found to be defective, and specifically excludes liability for incidental or consequential loss or damage.