



## C-37 SUBKIT

## FORD F-150 / F-250 LD

**WARNING!!** BRAKE, FUEL, AND ELECTRICAL LINES MAY NEED TO BE LOOSENED OR REPOSITIONED TO PROVIDE CLEARANCE FOR NEW HARDWARE.  
ALL MODELS REQUIRE MODIFICATION OR REMOVAL OF HEAT SHIELDS

### INSTALLATION STEPS

**\*\*REMOVE SPARE TIRE FOR INSTALLATION\*\***

- 1) Remove the heat shield located above the rear axle. The gas tank heat shield may also need to be cut along the top for some models.
- 2) Install cross arms by sliding them into gap between the truck bed and frame from inside the wheel well. **As shown in Figure 1.**
- 3) Hang the side plates from 5/8" studs, which extend from the cross arms. Fasten each plate with two 5/8" flange nuts provided. Finger tight only.
- 4) Align the side plates with the 5/8" slots in the frame. Place 5/8" carriage bolts through the side plate and frame as shown in **Figure 2**. Use 5/8" flange nuts on inside of frame to secure in place. Finger tight only.
- 5) Rotate the crossarms until they contact the truck bed. Center the rear cross arm studs in the side plate slots as shown in **Figure 3**. Use a 15/16" wrench to tighten the 5/8" flange nuts on the rear cross arm to the side plates. Repeat for both sides. **(Note: Do not tighten front cross arm until center section installation is complete.)**
- 6) With side plates and rear cross arm secure, position the drilling template provided between the cross arms as shown in **Figure 2**. Attach the template to cross arms using four 5/8" carriage bolts and flange nuts provided with the center section. Tighten the 5/8" flange nuts with a 15/16" socket. **(Note: Template must be positioned correctly based on application as shown in Figure 2.)**
- 7) **Be sure the cross arms are vertical to the truck bed before drilling!** Drill a 1/4" hole into the bed of the truck using the guide hole in the center of the template. Remove the template from the cross arm after the pilot hole has been drilled.

**\*\*\*RAPID INSTALL DIMENSION IS 45 7/16" FROM REAR OF TRUCK BED AS SHOWN ON PAGE 2\*\*\***

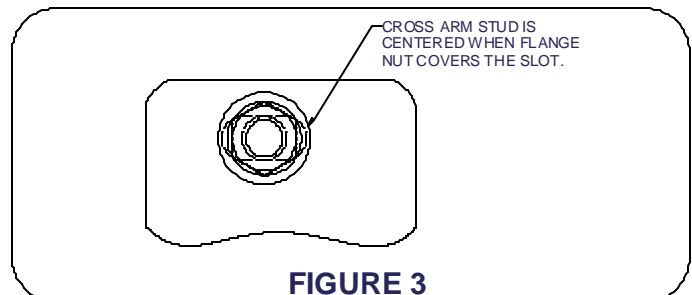
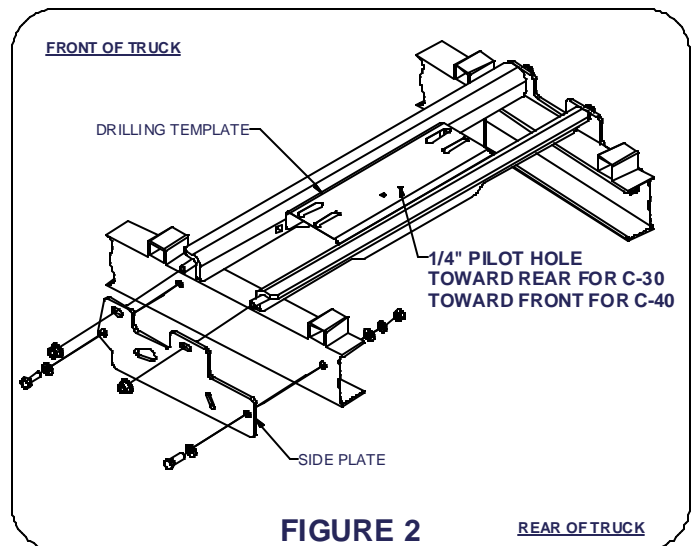
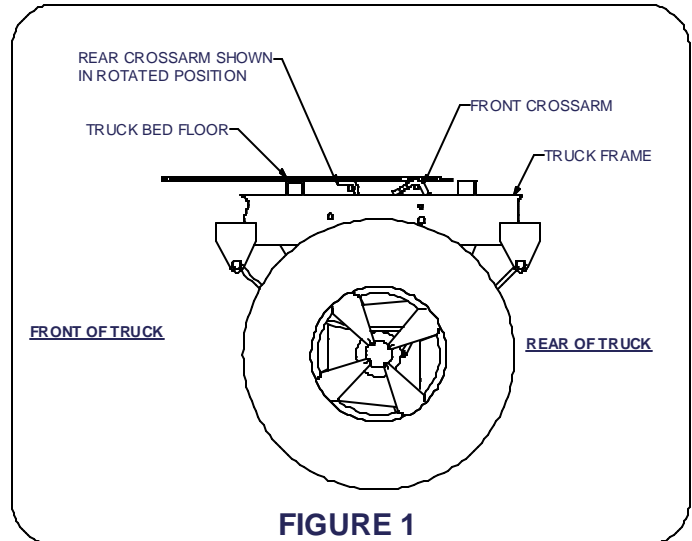

Curt Manufacturing Inc., warrants this product to be free of defects in material or workmanship at the time of retail purchase by the original purchaser. If the product is found to be defective, Curt Manufacturing Inc., may repair or replace the product, at their option, when the product is returned, prepaid, with proof of purchase. Alteration to, misuse of, or improper installation of this product voids the warrant. Curt Manufacturing Inc.'s liability is limited to repair or replacement of products found to be defective, and specifically excludes liability for incidental or consequential loss or damage.



C-37 SUBKIT

FORD F-150 / F-250 LD

**INSTALLATION STEPS CONT.**

- 8) From inside the truck bed, position the drilling template as it was under the vehicle in step 9. **(See Figure 4.)** To hold template position, place a 1/4" bolt thru the template and the new hole in the bed. Use a tape measure to square the drilling template by measuring from the tail gate end of bed to the template. Using a 5/8" drill bit, drill the center of each slotted hole in template. **(Note: Be sure the holes are drilled in the lower rib section of the truck bed as shown in Figure 5.)**
- 9) From inside the truck bed use a 3 5/8" hole saw to drill thru the bed. Use the previously drilled 1/4" hole as a guide. Use a file to deburr any sharp edges.
- 10) Torque the 5/8" hardware to 150 lb.-ft. Re-attach fuel, brake, and electrical lines that may have been loosened or removed during installation.
- 11) Follow the "Quick Goose" instructions for installation of the center section.

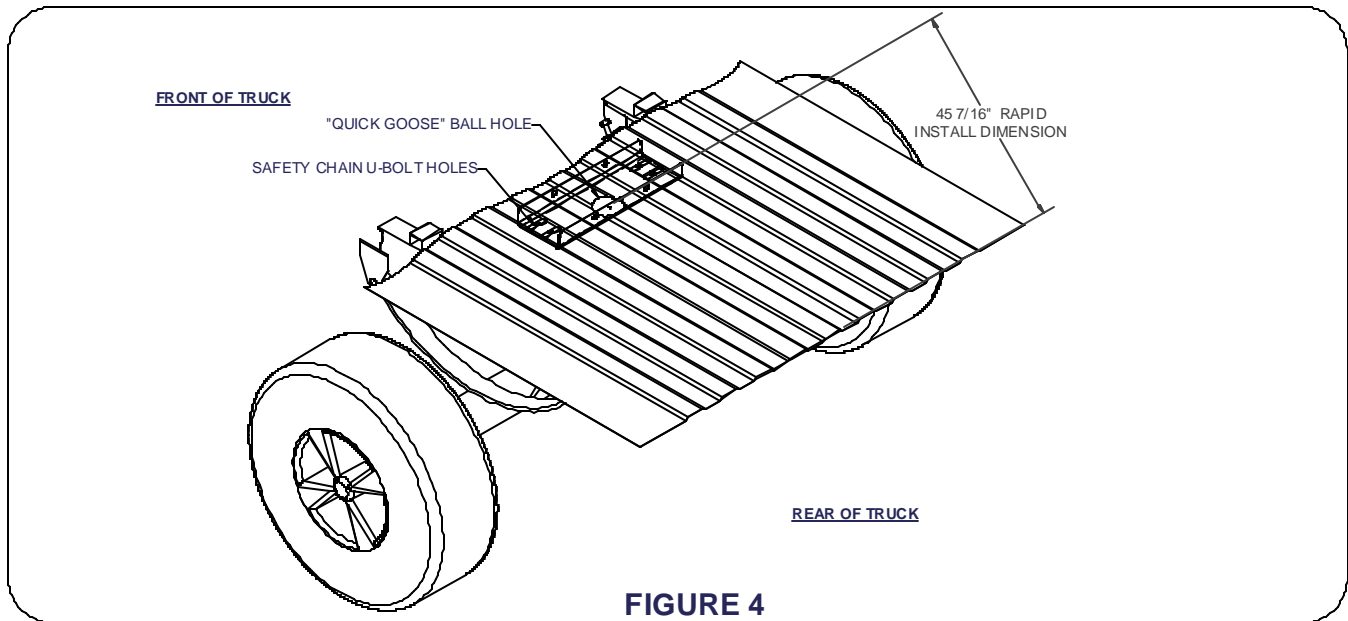

**FIGURE 4**

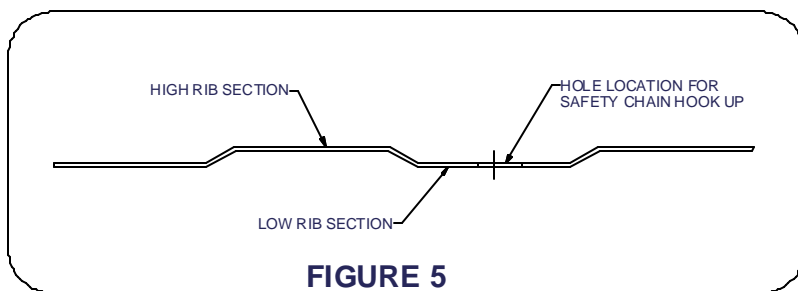
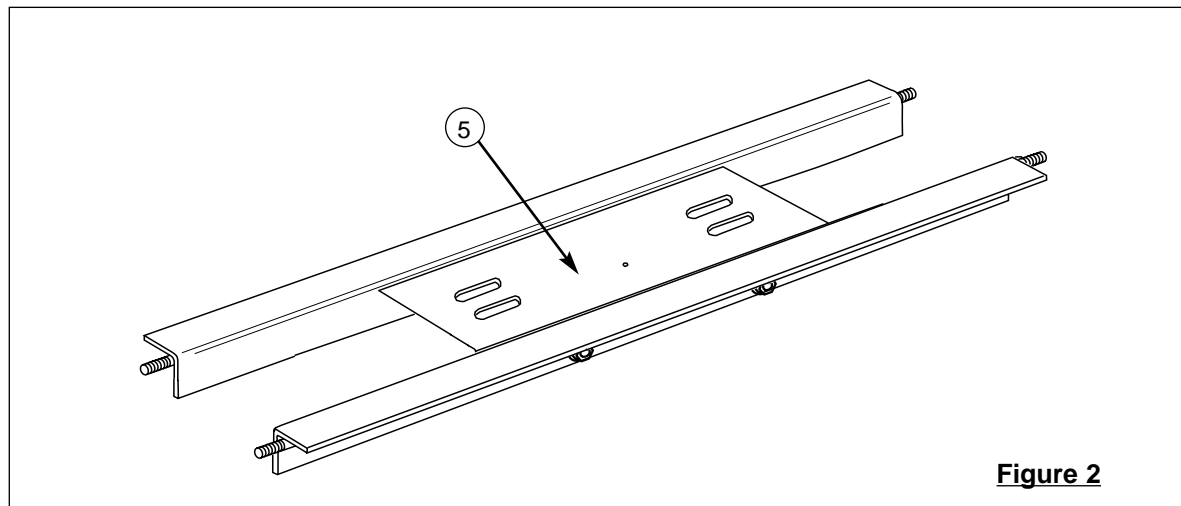
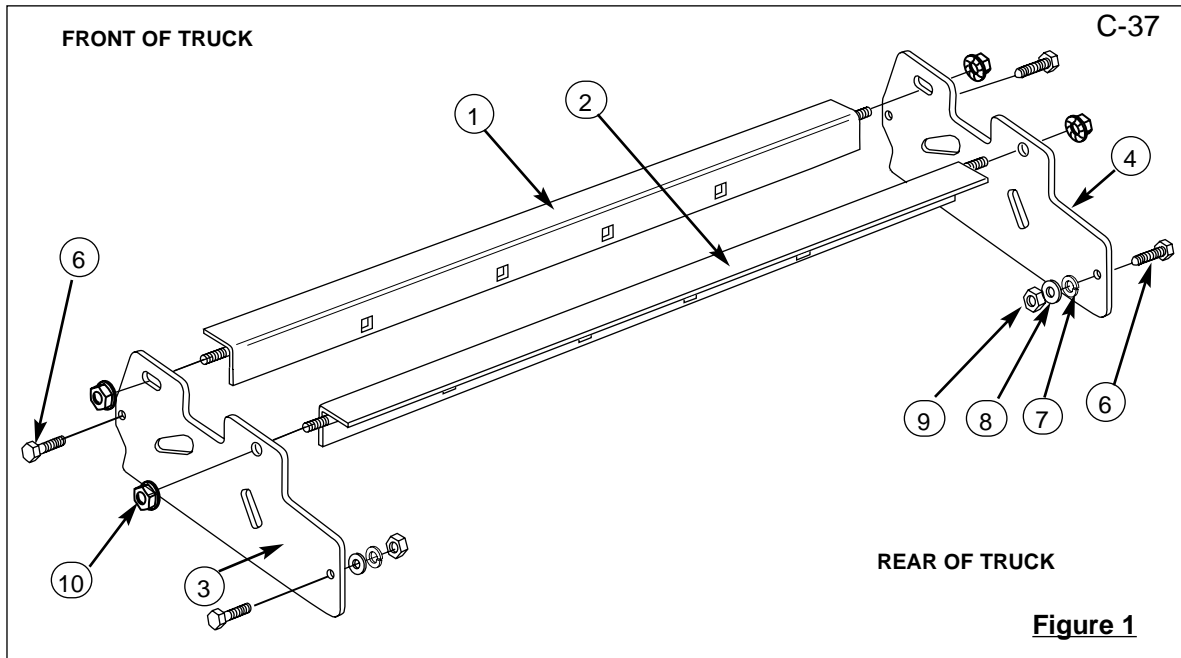

**FIGURE 5**

**PARTS LIST**

- (4) 5/8-11 x 1 3/4 " Carriage bolt Bolt
- (8) 5/8-11 Flange Nut
- (1) Installation Template (CM-308-2)

Curt Manufacturing Inc., warrants this product to be free of defects in material or workmanship at the time of retail purchase by the original purchaser. If the product is found to be defective, Curt Manufacturing Inc., may repair or replace the product, at their option, when the product is returned, prepaid, with proof of purchase. Alteration to, misuse of, or improper installation of this product voids the warrant. Curt Manufacturing Inc.'s liability is limited to repair or replacement of products found to be defective, and specifically excludes liability for incidental or consequential loss or damage.



<b>PARTS LIST</b>		
<b>Item #</b>	<b>Qty.</b>	<b>Description</b>
1	1	Front cross member
2	1	Rear cross member
3	1	Driver side mount plate
4	1	Passenger side mount plate
5	1	Drilling template
6	4	9/16-12 x 1.50 Grade 5 Hex bolt
7	4	9/16 Lockwasher
8	4	9/16" Flatwasher
9	4	9/16" Grade 5 Hex nut
10	4	5/8-11 Grade 5 Flange nut

\*\*\*\*\* ALL HARDWARE MUST BE PROPERLY TORQUED \*\*\*\*\*