

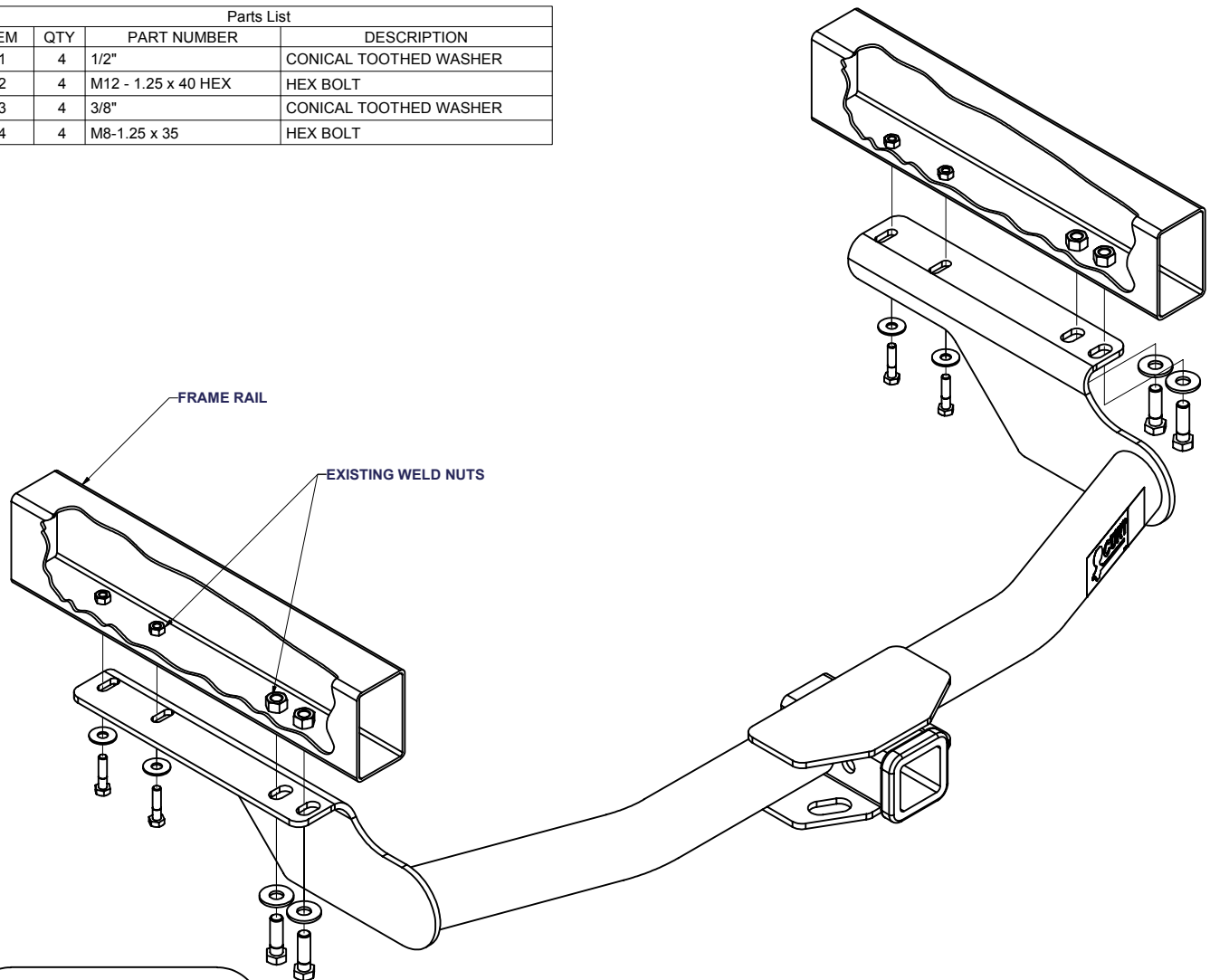

13445 LEXUS GX470 & TOYOTA 4-RUNNER

GROSS LOAD CAPACITY WHEN USED AS A WEIGHT CARRYING HITCH: 5,000 LBS. TRAILER WEIGHT & 500 LBS. TONGUE WEIGHT.
GROSS LOAD CAPACITY WHEN USED AS A WEIGHT DISTRIBUTION HITCH: 5,500 LBS. TRAILER WEIGHT & 550 LBS. TONGUE WEIGHT
*****DO NOT EXCEED VEHICLE MANUFACTURER'S RECOMMENDED TOWING CAPACITY.*****

Parts List			
ITEM	QTY	PART NUMBER	DESCRIPTION
1	4	1/2"	CONICAL TOOTHED WASHER
2	4	M12 - 1.25 x 40 HEX	HEX BOLT
3	4	3/8"	CONICAL TOOTHED WASHER
4	4	M8-1.25 x 35	HEX BOLT



HITCH WEIGHT: 33 LBS.

INSTALL TIME: 25 MINUTES

INSTALL NOTES:

Remove Tow Hooks
No Drill

INSTALLATION STEPS

- 1) Remove tow hooks if present.
- 2) Maneuver passenger side plate over the exhaust and hold hitch up against frame.
- 3) Line up holes in the hitch side plates to existing weldnuts in frame. Install M12 and M8 bolts as shown.
- 4) Torque all M12 fasteners to 65 lb.-ft. Torque all M8 fasteners to 17 lb.-ft.

PERIODICALLY CHECK THIS RECEIVER HITCH TO INSURE THAT ALL FASTENERS ARE TIGHT AND THAT ALL STRUCTURAL COMPONENTS ARE SOUND.

Curt Manufacturing Inc., warrants this product to be free of defects in material and/or workmanship at the time of retail purchase by the original purchaser. If the product is found to be defective, Curt Manufacturing Inc., may repair or replace the product, at their option, when the product is returned, prepaid, with proof of purchase. Alteration to, misuse of, or improper installation of this product voids the warranty. Curt Manufacturing Inc.'s liability is limited to repair or replacement of products found to be defective, and specifically excludes liability for incidental or consequential loss or damage.