

GROSS LOAD CAPACITY WHEN USED AS A WEIGHT CARRYING HITCH: 6,000 LBS. TRAILER WEIGHT & 600 LBS. TONGUE WEIGHT.  
 GROSS LOAD CAPACITY WHEN USED AS A WEIGHT DISTRIBUTION HITCH: 10,000 LBS. TRAILER WEIGHT & 1,000 LBS. TONGUE WEIGHT  
**\*\*\*DO NOT EXCEED VEHICLE MANUFACTURER'S RECOMMENDED TOWING CAPACITY.\*\*\***

Parts List			
ITEM	QTY	PART NUMBER	DESCRIPTION
1	2	CM-SP1	.250 x 1.50 x 2.00" SQUARE HOLE SPACER
2	2	1/2 - 13 x 1 3/4	CARRIAGE BOLT
3	2	1/2 - 13	HEX FLANGE NUT
4	4	M14-2 x 40mm LG.	HEX BOLT
5	4	1/2"	CONICAL TOOTHED WASHER

**NOTE: FASTENERS TYPICAL BOTH SIDES**

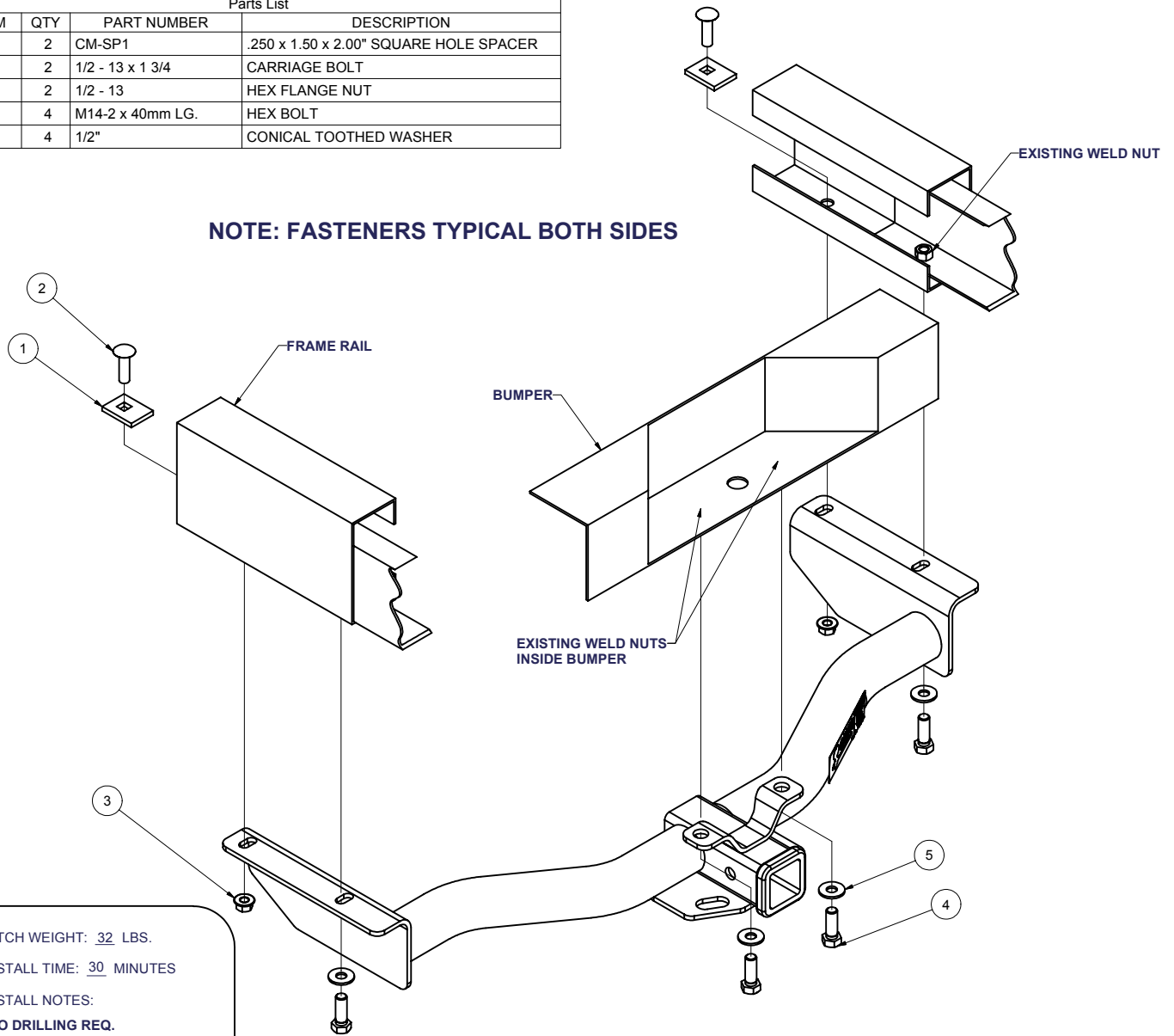

HITCH WEIGHT: 32 LBS.  
 INSTALL TIME: 30 MINUTES  
 INSTALL NOTES:  
**NO DRILLING REQ.**

**INSTALLATION STEPS**

- 1) Remove existing M14 bumper bracket bolts from the bottom surface of frame and return to vehicle owner. (Both sides)
- 2) Raise hitch into position and install fasteners as shown.
- 3) Torque all 1/2" fasteners to 75 lb.-ft. Torque all M14 fasteners to 148 lb.-ft.

**PERIODICALLY CHECK THIS RECEIVER HITCH TO INSURE THAT ALL FASTENERS ARE TIGHT AND THAT ALL STRUCTURAL COMPONENTS ARE SOUND.**

Curt Manufacturing Inc., warrants this product to be free of defects in material and/or workmanship at the time of retail purchase by the original purchaser. If the product is found to be defective, Curt Manufacturing Inc., may repair or replace the product, at their option, when the product is returned, prepaid, with proof of purchase. Alteration to, misuse of, or improper installation of this product voids the warranty. Curt Manufacturing Inc.'s liability is limited to repair or replacement of products found to be defective, and specifically excludes liability for incidental or consequential loss or damage.