

10/12/2006

GROSS LOAD CAPACITY WHEN USED AS A WEIGHT CARRYING HITCH: 2000 LBS. TRAILER WEIGHT & 200 LBS. TONGUE WEIGHT.
*****DO NOT EXCEED VEHICLE MANUFACTURER'S RECOMMENDED TOWING CAPACITY.*****

Parts List			
ITEM	QTY	PART NUMBER	DESCRIPTION
1	4	M10-1.25 x 35	HEX TAP BOLT
2	4	3/8"	CONICAL TOOTHED WASHER
3	1	D-55001	1 1/4" CURT BALL MOUNT
4	1	F-4 PIN	HITCH PIN
5	1	F-4 CLIP	HITCH PIN CLIP

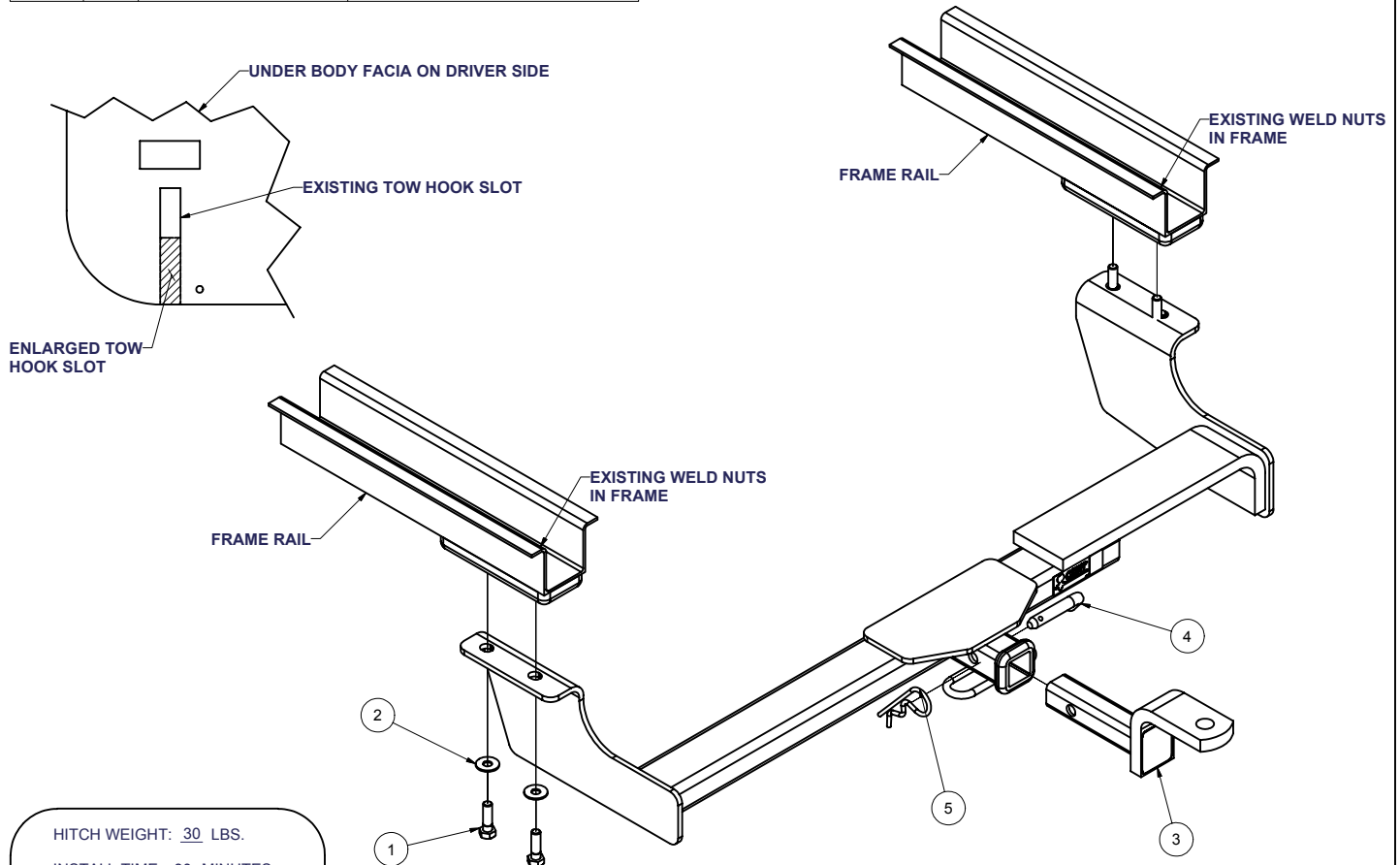

HITCH WEIGHT: 30 LBS.

INSTALL TIME: 30 MINUTES

INSTALL NOTES:

NO DRILLING REQUIRED
TRIM UNDER BODY FACIA

INSTALLATION STEPS

- 1) Remove tow hooks. (Return to customer)
- 2) Remove plastic under body fascia on driver side.
- 3) Lift hitch into position and secure with M10 bolts and conical washers as shown.
- 4) Torque all M10 fasteners to 35 lb-ft.
- 5) Enlarge tow hook slot on under body fascia to fit around driver side plate as shown.
- 6) Reinstall under body fascia with existing hardware.

PERIODICALLY CHECK THIS RECEIVER HITCH TO ENSURE THAT ALL FASTENERS ARE TIGHT AND THAT ALL STRUCTURAL COMPONENTS ARE SOUND.