

BX1305
2007-09 BMW Mini Cooper
(Includes S & Clubman Models)
(Not Convertible)
Installation Instructions

Serial Number

Please read **BOTH** these Installation Instructions and the General Towing Instructions before attempting to install or operate this equipment.

1. Blue Ox® towing products and accessories are intended to be installed by Blue Ox® Dealers who are familiar with our products and have the equipment and knowledge to do “fit work.” When necessary, Blue Ox® Dealers can be found at www.blueox.us or by contacting our Customer Care Department at (888) 425-5382.

Attachment Tab Height: 13.5”
Attachment Tab Width: 20”

2. Many Blue Ox® Baseplates are designed to use existing holes and hardware to mount the baseplate to the towed vehicle. Even though bolts are there, do not assume they are adequate for baseplate mounting. Always use hardware supplied in the hardware kit or existing hardware specified in the Baseplate Towing Installation Instructions.

Bolt Torque Specifications

Torque in Foot-Pounds for Metric Bolts

Bolt Size	Grade 8.8	Grade 10.9
6MM	6	8
8MM	16	22
10MM	31	40
12MM	54	70
14MM	89	117

Confirm the towability and pre-towing procedures for your vehicle with the owner’s manual or contact the vehicle’s manufacturer for specific towing procedures.

Bolt Torque Specifications

Torque in Foot-Pounds for Inch Bolts

Bolt Size	Grade 5	Grade 8
1/4”	10	14
5/16”	19	29
3/8”	33	47
7/16”	54	78
1/2”	78	119
5/8”	154	230

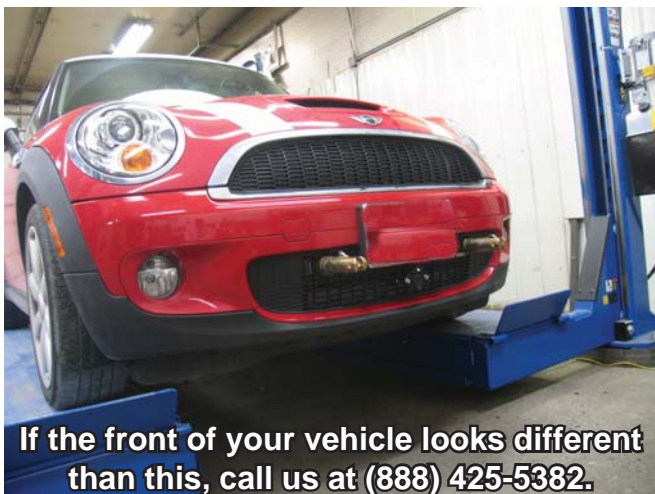

If the front of your vehicle looks different than this, call us at (888) 425-5382.

! WARNING

Failure to read and follow these instructions could result in separation of the towed vehicle from the tow bar, causing property damage, loss of towed vehicle, personal injury or death.

BX1305 2007-09 BMW Mini Cooper (Includes S & Clubman Models) (Not Convertible)

Installation Instructions

Parts List

Ref. No.	Qty.	Part #	Description
1	1	61-6539	Weldment, Baseplate, BX1305
2	8	61-5208	Weldment, Nut Plate, 1/4 x 1 x 1, 3/8"
3	8	201-0368	3/8-16 x 1 1/4" Hex Head Bolt, Grd. 5, ZP
4	10	203-0010	3/8" Lock Washer, ZP
5	4	203-0003	3/8" Flat Washer, ZP
6	2	201-0419	8MM-1.25 x 50MM Hex Bolt, Grd. 8.8, ZP
7	2	201-0553	1/4-20 X 1/2" Hex Washed Type F, ZP
8	2	201-0192	#10-32 x 1/2" Slot, Round Head Screw
9	2	203-0054	#10 Lock Washer
10	2	202-0047	#10-32 Hex Nut
11	2	101-5822	Adapter, 4 Way Connector
12	2	62-3468	Attachment, Assembly, SF/SB, 1 Hole
13	2	102-6816	Backing Plate, BX1304
	2	290-0437	Cap Plug, Black (not shown)
	4	229-0359	Quicklink, 3/8", ZP (not shown)
	2	226-0046	Baseplate Safety Cable, 36" Class III (not shown)

Tools Required

13MM Socket	14MM Socket
9/16" Socket	T25 Torx
Reciprocating Saw	1 1/4" Hole Saw
13/32" Drill Bit	Flat Screw Driver
Phillips Screw Driver	Utility Knife
Loctite RED	

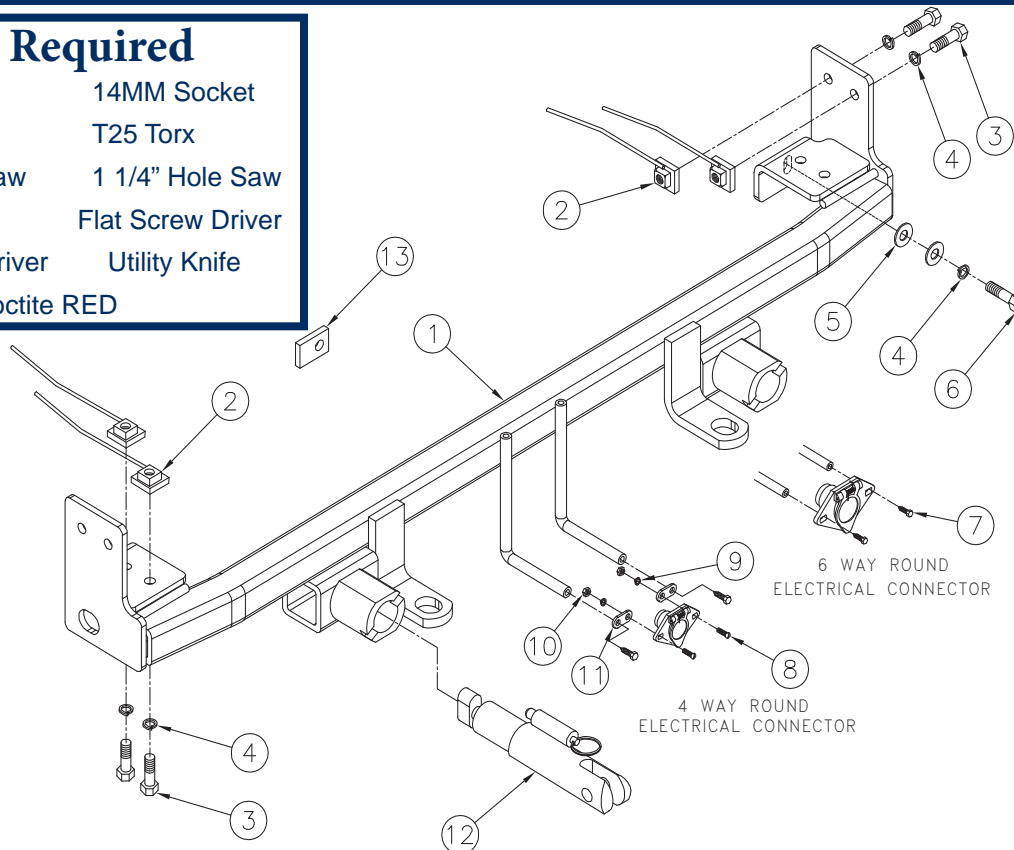

Important:

Use only genuine factory replacement parts on your baseplate. Do **NOT** substitute homemade or non-typical parts. If a bolt is lost or in need of replacement, for your safety and the preservation of your baseplate, be sure to use a replacement bolt of the same grade (In most cases it will be Grade 5, please reference the parts list above). Replacement parts may be ordered through your nearest Blue Ox® Dealer or Distributor. Failing to follow and/or altering these installation instructions in either installation or required equipment will void the manufacturer's warranty.

BX1305
2007-09 BMW Mini Cooper (Includes S
& Clubman Models) (Not Convertible)

Installation Instructions

Vehicle Weight:

Motorhome mount tow bars are recommended for use with this baseplate. Due to the design of the removable tabs, the RangeFinderII, Adventurer, and Ambassador tow bars can not be used. The Acclaim tow bar may be used, but will not fold and store on the front of the vehicle. Adapters, except the BX8833 and BX88151, can not be used with this baseplate.

Tow Bar Adapters are NOT to be used with vehicles weighing over 5,000 lbs.

Installation Notes: The fascia and grille are removed and reinstalled during installation of the baseplate. Drilling is required. Trimming of the fascia is required.

The dimensional variations between otherwise identical vehicles can be considerable. While the baseplate was designed for easy installation, it may be necessary to tailor the baseplate slightly to compensate for auto manufacturer's tolerances. These minor adjustments may include filing a hole slightly, bending electrical rods or bending end plates.

The BX8848 Diode Wiring Kit is recommended for this vehicle.

Installation Instructions:



1. Using a flat screw driver, remove four push pins on top edge of grille. Set push pins aside to be reinstalled later.



2. Forward the front tire, use a Phillips screw driver to remove two push pins. Do this to both sides and set aside for later reinstallation.

BX1305
2007-09 BMW Mini Cooper (Includes S
& Clubman Models) (Not Convertible)

Installation Instructions



3. After removing the wheel well cover, use a flat screw driver to remove the two push pins connecting the fascia. Do this to both sides. Set push pins aside for later reinstallation. Push and release the two clips holding the gray cover, then use the T25 Torx to loosen the bolt.

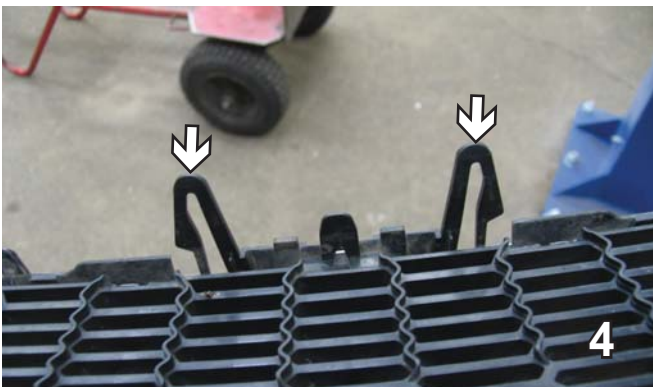

4. Remove the grille by releasing the clips. Reach in from the top and squeeze the clip together. Set aside for later reinstallation.

5. Use a T25 Torx to remove the two bolts from the top edge of the fascia one on each side. Set aside for later reinstallation.



6. Squeeze together the two clips holding the hose to release it and let it drop down.

7. Underneath the fascia, use a T25 Torx to remove the screw on the edge from both sides (gray arrow). Also remove the three push pins in the center (white arrow). Pull the fascia corner out to the side of the vehicle, both sides, then pull the fascia forward and set aside carefully for later reinstallation.

BX1305
2007-09 BMW Mini Cooper (Includes S
& Clubman Models) (Not Convertible)

Installation Instructions



8. Use the reciprocating saw to cut off the bolt even with the nut. Do this on both sides.

Using a good quality paint, spray cut edges of frame to prevent rusting.



9. Remove the hose bracket and use the hole as the location to drill a hole with the 1 1/4" hole saw to use for inserting nut plates. Do this on both sides. The hose will not be replaced as it will be mounted on top of the fascia.

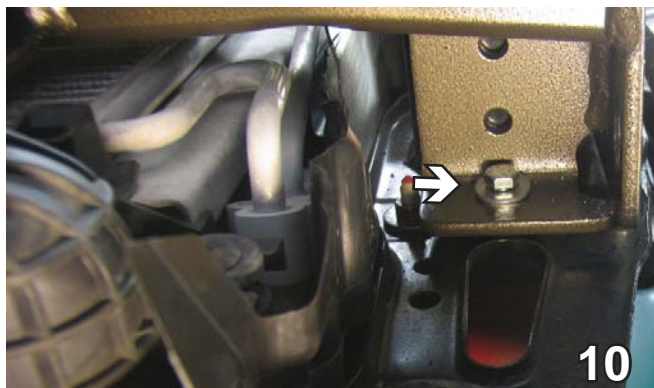

10. Slide the baseplate up and underneath, align with existing hole. Using a 13MM socket, start 8MM-1.25 x 50MM bolt with 3/8" lock washer and 3/8" flat washer. Using the baseplate as a template, drill the additional two holes on the bottom with a 13/32" drill bit. Do this to both sides.

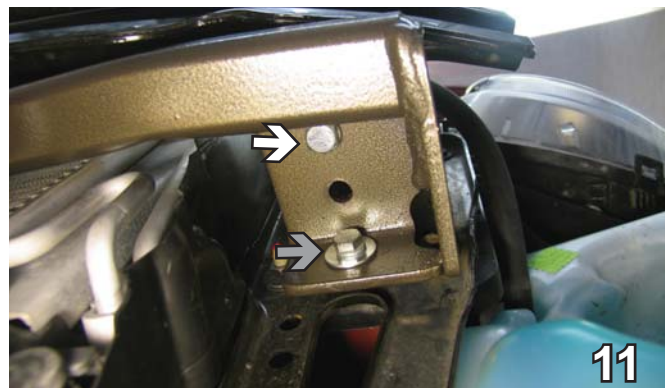

11. Insert and tighten with Loctite 3/8-16 x 1 1/4" bolt with 3/8" lock washer in the top hole and 3/8-16 nut plate inserted into the 1 1/4" hole. Then tighten with Loctite the bolt inserted in step 10 (gray arrow). Finally insert the third bolt. They must be done in this order for them all to go in.

BE SURE TO USE LOCTITE® RED ON ALL BOLTS BEFORE TIGHTENING. TIGHTEN ALL BOLTS ACCORDING TO THE TORQUE CHART ON THE FRONT PAGE OF THESE INSTRUCTIONS OR ON PAGE 3 OF THE BASEPLATE TOWING GENERAL INSTRUCTIONS.



12. Using the baseplate as a template, drill the two holes on the side with a 13/32" drill bit. Insert bolts with Loctite, lock washers and nut plates.

BX1305 2007-09 BMW Mini Cooper (Includes S & Clubman Models) (Not Convertible)

Installation Instructions



13. On top of the bumper, remove the nut add a backing plate and reinstall with Loctite. Do this on both sides.

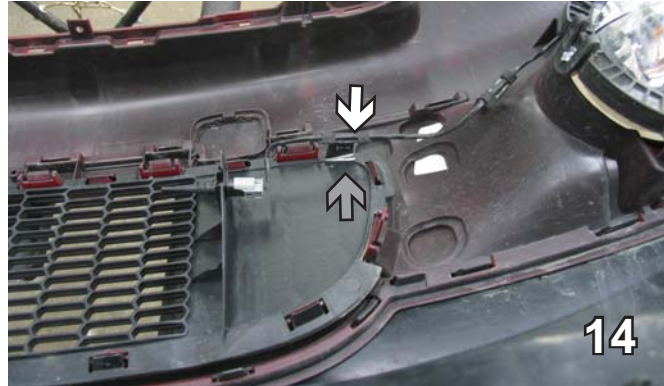

14. On the back side of the fascia, passenger side, pull up the sensor. Using a utility knife, cut off the tab (gray arrow).



15. Continuing on the back side of the fascia, using a utility knife trim down to the gusset and straight out (as shown). Do this on both sides.



16. Make a notch and move the sensor down.

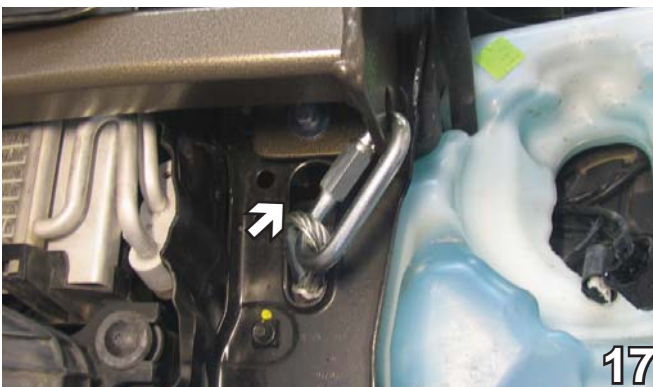

17. Attach the permanent baseplate safety cables to the provided convenience link on the baseplate. The photo above shows the recommended installation of the cables to frame of vehicle (see white arrow). Additional options may interfere with suggested mounting; in this case secure the cables to a solid piece of the frame as described in the instructions included with the permanent baseplate safety cables. Be sure the safety cables do not rub against any hoses or moving parts. Do this to both sides of the vehicle.

Be sure that **ALL** electrical connections are plugged in properly and functioning **BEFORE** installing the fascia.

18. Reinstall the grille and fascia.

Install the tow bar according to the instructions included in its package. When demonstrating this to the customer, be sure to include all the contents and packages.

Do NOT substitute other devices if the tow bar pin and clip are misplaced.

BX1305
2007-09 BMW Mini Cooper (Includes S
& Clubman Models) (Not Convertible)

Installation Instructions

DEALER or INSTALLER:
Be certain the user receives the
instruction sheets for their products.



Shown without removable tabs installed.



Shown with removable tabs installed.

If the baseplate is in an accident, it must be replaced. DO NOT use it again! An accident can cause unseen damage and using it again could result in more damage or serious injury. DO NOT use the baseplate if it is damaged or missing parts.

CUSTOMER SERVICE COMMITMENT

Blue Ox is committed to providing you with exceptional customer care throughout your lifetime with our products. Our team is here to assist you with any questions you may have regarding the performance of your product. Simply call 1-800-228-9289 and you can speak with our customer care team.

Additionally, please visit our website to see which rallies our Destination America team will be attending. For a nominal fee, our service technician will service your towing system to ensure it's in proper working condition. Also as a commitment to our customers, should you visit our factory you can stay at our full service Blue Ox campground at no charge along with enjoying a factory tour.

Again thank you for being our customer and for the confidence you have shown in the performance of our products. It is because of customers like you we enjoy the success we have today.



© 2007, 08, 08, 09 Blue Ox
One Mill Road, Industrial Park
Pender, Nebraska 68047
Phone: (402) 385-3051 • Fax: (402) 385-3360
www.blueox.us