



BX3786

2011-12 Toyota 4 Runner SR5 Installation Instructions

Attachment Tab Height: 24-1/2"

Attachment Tab Width: 21"

Serial Number

Please read BOTH these Installation Instructions and the General Information sheet prior to installing or operating this equipment.

1. Blue Ox® towing products and accessories are intended to be installed by Blue Ox® Dealers who are familiar with our products and have the equipment and knowledge necessary to do "fit work". If needed, Blue Ox® Dealers can be found at www.blueox.com or by contacting our Technical Service Department at (402) 385-3051.
2. Many Blue Ox® baseplates are designed to use existing holes and hardware to mount the baseplate to the towed vehicle. Even though bolts are there, do not assume they are adequate for baseplate mounting. Always use the hardware supplied in the hardware kit and existing hardware as specified in the installation instructions.



If the front of your vehicle looks different than this, please contact us at (402)385-3051.

Reference your vehicle owner's manual for manufacturer's towing specifications.

Bolt Torque Specifications

Torque in Foot-Pounds for Inch Bolts

Bolt Size	Grade 5	Grade 8
1/4"	10	14
5/16"	19	29
3/8"	33	47
7/16"	54	78
1/2"	78	119
5/8"	154	230
3/4"	257	380

Bolt Torque Specifications

Torque in Foot-Pounds for Metric Bolts

Bolt Size	Grade 8.8	Grade 10.9
6MM	6	8
8MM	16	22
10MM	31	40
12MM	54	70
14MM	89	117
16MM	161	230
18MM	222	318

WARNING

Failure to read and follow these instructions could result in separation of the towed vehicle from the tow bar, causing property damage, loss of towed vehicle, personal injury or death.

BX3786
2011-12 Toyota 4 Runner SR5
Installation Instructions

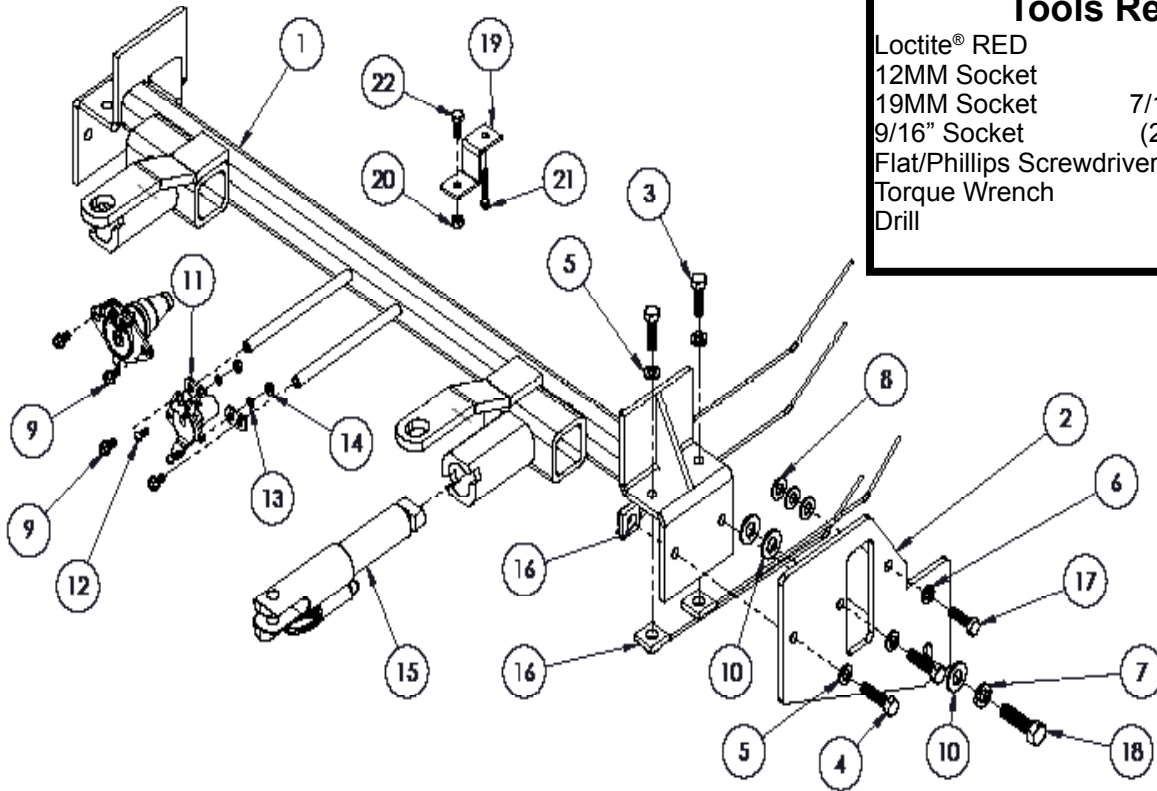

Tools Required	
Loctite® RED	10MM Socket
12MM Socket	14MM Socket
19MM Socket	7/16" Socket Wrench
9/16" Socket	(2) Large Vise Grips
Flat/Phillips Screwdriver	Utility Knife
Torque Wrench	Tape Measure
Drill	13/32" Drill Bit
	1 1/4" Hole Saw

Item No.	Qty.	Part #	Description
1	1	61-6915	WLDM'T, BP, BX3786
2	2	101-7788	SUPPORT, PLATE BX3758
3	4	201-0368	3/8-16 X 1 1/4" HEX HEAD BOLT
4	4	201-0440	3/8-16 X 1 1/2" HEX BOLT, GRD. 5, ZP
5	8	203-0010	3/8" LOCK WASHER, ZP
6	2	203-0102	8MM LOCK WASHER, ZP
7	2	203-0105	12MM LOCK WASHER, ZP
8	6	203-0003	3/8" FLAT WASHER, ZP
9	2	201-0979	#12-14 X 1" SELF DRILLING SCREW, ZP
10	6	203-0005	1/2" FLAT WASHER, ZP
11	2	101-5822	ADAPTER, 4 WAY CONNECTOR
12	2	201-0192	#10-32-1/2" SLOT, ROUND HEAD SCREW
13	2	203-0054	#10-32 LOCK WASHER, ZP
14	2	202-0047	#10-32 HEX NUT
15	2	62-3469	ATT TAB ASSY, REM, SF/LB, 1 HOLE
16	8	61-5208	WLD, NUT PLATE, 1/4 X 1 X 1(3/8-16)w/ 14" WIRE
17	2	201-0446	8MM-1.25 X 30MM, HEX BOLT, BRD. 8.8, ZP
18	2	201-0603	12MM-1.25 X 45MM, HEX BOLT, GRD. 8.8, ZP
19	1	102-7134	BREAKAWAY BRKT
20	1	202-0102	1/4-20 HEX NYL NUT, ZP
21	1	201-0050	1/4-20 x 3/4 HEX BOLT, GRD. 5, ZP
22	1	201-0654	#10-16 X 1" SELF DRILLING SCREW, ZP
23	2	290-0437	RECEIVER, CAP PLUG (BLK) (Not Shown)
24	2	226-0049	BASEPLATE SAFETY CABLE, 36" CLASS IV (Not Shown)
25	2	229-0512	Quick link, 1/2", ZP (not shown)

Important:

Use only genuine factory replacement parts on your baseplate. Do **NOT** substitute homemade or non-typical parts. If a bolt is lost or in need of replacement, for your safety and the preservation of your baseplate, be sure to use a replacement bolt of the same grade (In most cases it will be Grade 5, please reference the parts list above). Replacement parts may be ordered through your nearest Blue Ox® Dealer or Distributor. Failing to follow and/or altering these installation instructions in either installation or required equipment will void the manufacturer's warranty. Towing behind a non-motorized vehicle will void the warranty.

BX3786
2011-12 Toyota 4 Runner SR5
Installation Instructions

Instruction Notes: The fascia, belly pan and bumper are removed and reinstalled for the baseplate installation. Some drilling and trimming is required.

Place all components that are removed on a flat, sturdy surface. All items will be reinstalled unless otherwise noted after the baseplate is installed.

The dimensional variations between otherwise identical vehicles can be considerable. While the baseplate was designed for easy installation, it may be necessary to tailor the baseplate slightly to compensate for vehicle manufacturer's tolerances.

The BX8848 4-Diode Wiring Kit is recommended for this vehicle.

NOTICE

- Handling of some cosmetic parts when installing this product may require the use of protective covers, rags, specialty tools, etc. to prevent damage.
- When using power drills be aware of the dangers of torque and drill bit length.
- When using a reciprocating saw be aware of objects behind the cutting surface.
- Use a good quality paint to spray cut edges of frame to prevent rusting.
- Be sure that **ALL** electrical connections are plugged in and accessories are functioning properly before reinstalling the fascia.
- The baseplate is computer tested to your vehicle's GVWR, exceeding this weight will void the manufacturer's warranty.
- Be sure to use a sufficient amount of Loctite® Red on all bolt threads before tightening. Tighten all bolts according to the torque chart provided.
- Dealer or installer be certain the user receives these instruction sheets.
- If the baseplate is in an accident, it must be replaced. **DO NOT** use it again! An accident can cause unseen damage and using it again could result in more damage or serious injury. **DO NOT** use the baseplate if it is damaged or missing parts.

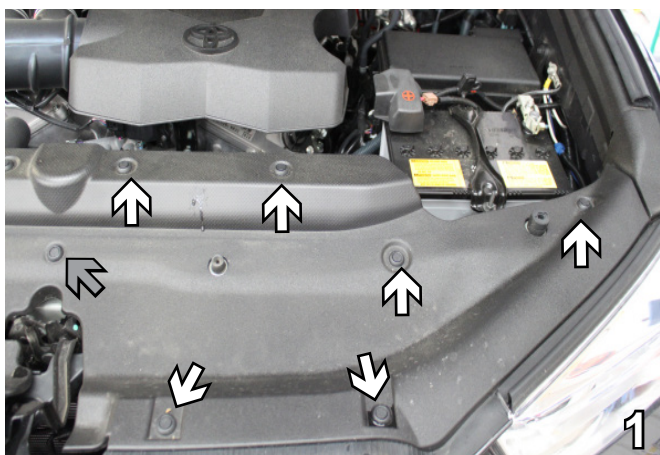

1. Remove six push pins on both sides of the vehicle (white arrows) and one push pin from the middle (gray arrow) of the plastic cover on top of the fascia. Set push pins aside to be reinstalled later.

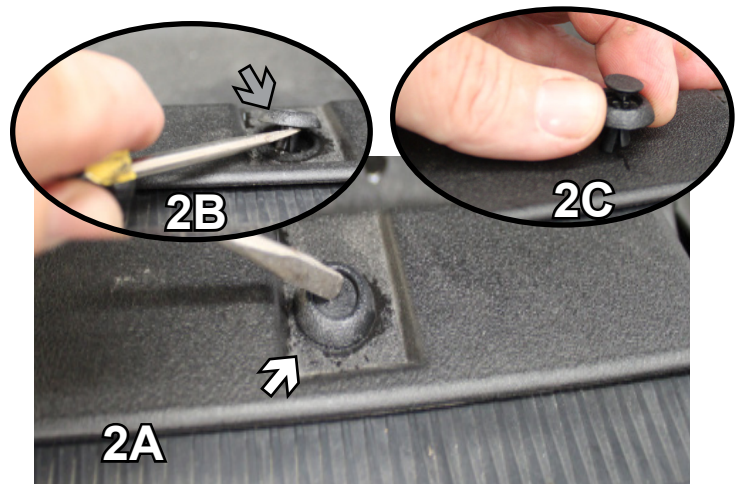

2. To remove some of the push pins, push the inner pin down until it locks with a flat screwdriver (2A, white arrow), then use the screwdriver to pry the outer pin up (2B, gray arrow). To reinstall push pins, push outer ring down until the inner pin pops back up (2C).

BX3786
 2011-12 Toyota 4 Runner SR5
 Installation Instructions

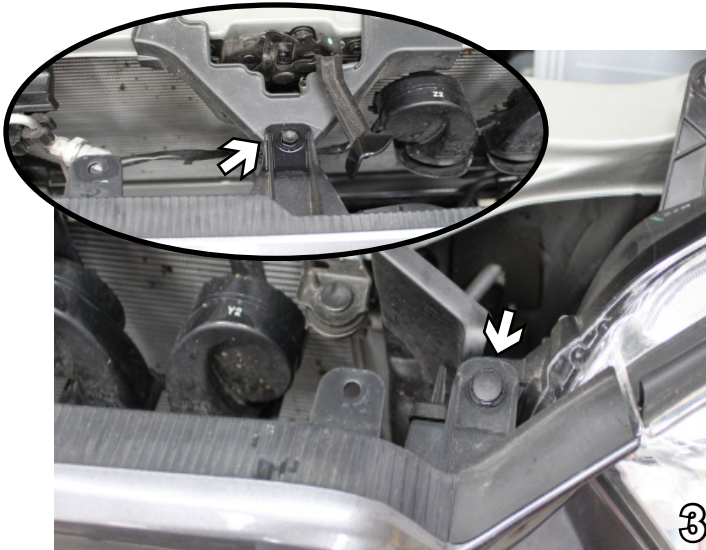

- Using a 10MM socket, remove the bolt from the center of the vehicle. Use a flat screwdriver to remove a push pin from each side of the vehicle, located near each headlight. Set push pins and bolt aside to be reinstalled later.



- Using either a 10MM socket or a phillips screwdriver, remove three screws located in the driver's side wheel well in front of the tire. Do this on both sides. Set screws aside to be reinstalled later.

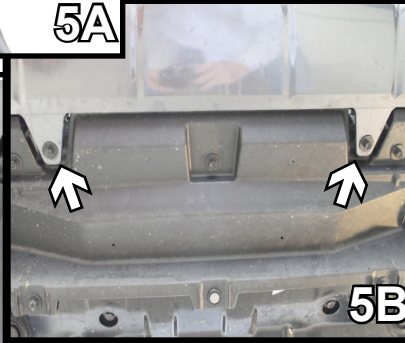
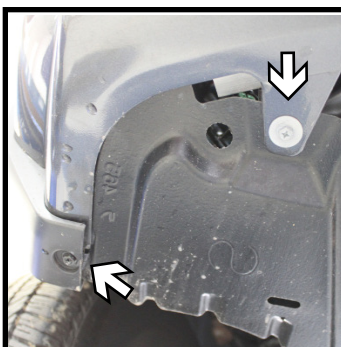
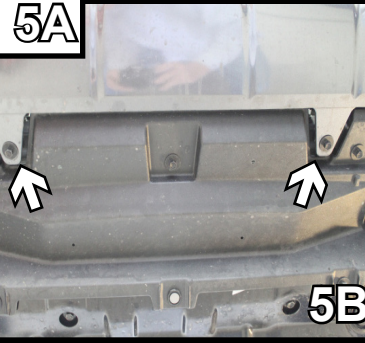
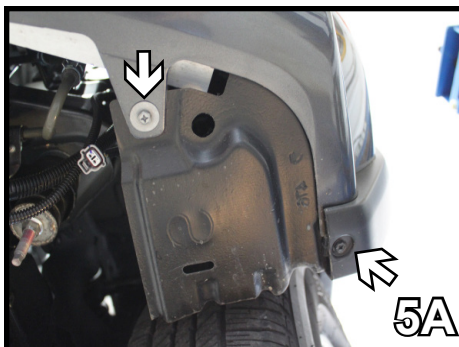

- Starting in front of the driver's side front tire (5A), use a 10MM socket to remove the six bolts from the underside (5B) of the fascia following the front bumper to the passenger's side (5C). Unplug the running and fog lights located in the center of the vehicle. Set bolts aside to be reinstalled later.

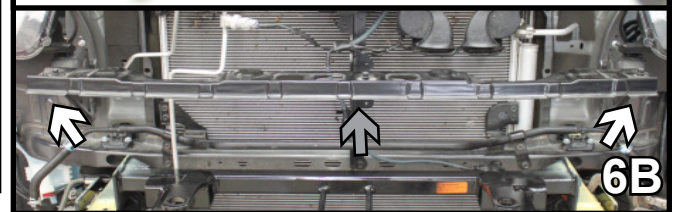
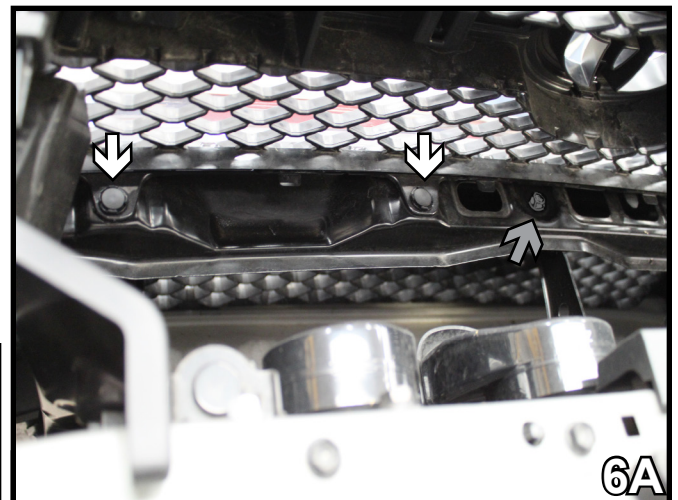

- Remove the push pins from the back side of the grill (A, white arrows). Use a 10MM socket to remove the bolt from the center of the grill (A, gray arrow). Once the grill is off, locate the other two 10MM bolts located near each headlight and remove them and the black rail (B). Remove fascia and grill then set push pins, bolts, fascia and grill aside to be reinstalled later.

BX3786
2011-12 Toyota 4 Runner SR5
Installation Instructions



7. Using a flat screwdriver, remove the push pin connecting the plastic deflector from the driver's side. Do this on both sides. Then remove the white styrofoam bumper from the front of the vehicle. Set all items aside to be reinstalled later.

9. Underneath the bumper, remove a 10MM bolt with a 10MM socket from each side of the vehicle (A and C). Remove the 10MM bolt in the center (B). Remove bumper and set aside with bolts to be reinstalled later.

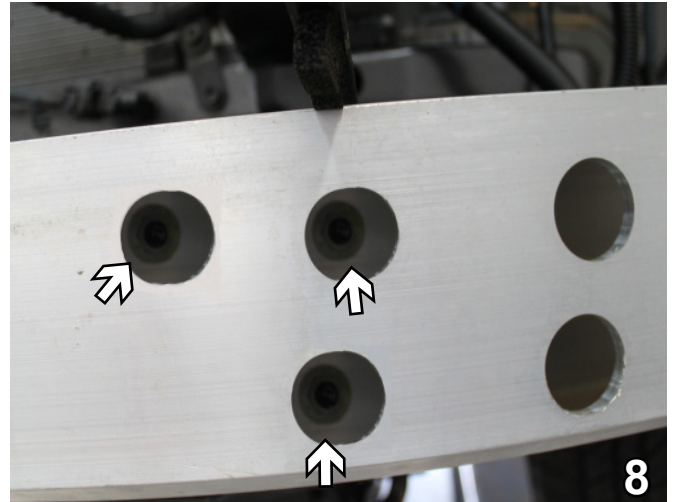
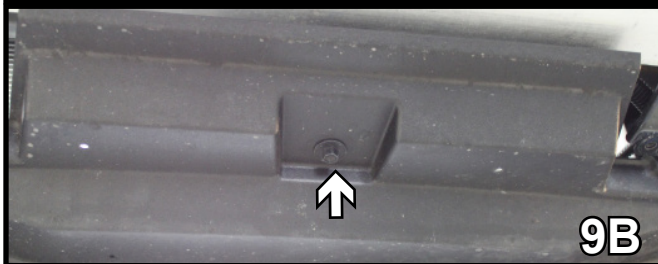
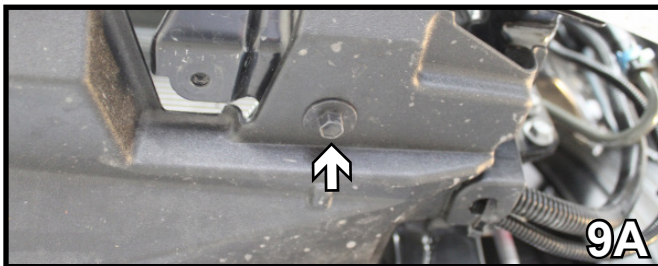

8. Use a 14MM socket to remove three bolts from the front bumper on each side of the vehicle.

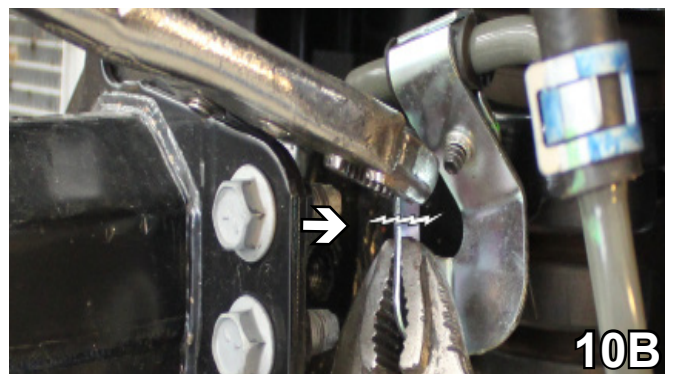
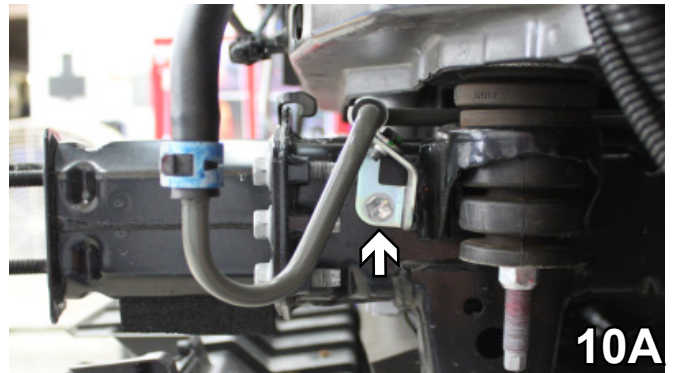

10. Using a 12MM socket, remove the bolt for the tubing bracket on each side of the vehicle (A). Then, using two pairs of large vice grips, bend the upper section of the bracket back and forth to break the top section of each bracket off (B). The bolts and removed sections will not be reinstalled.

BX3786
2011-12 Toyota 4 Runner SR5
Installation Instructions

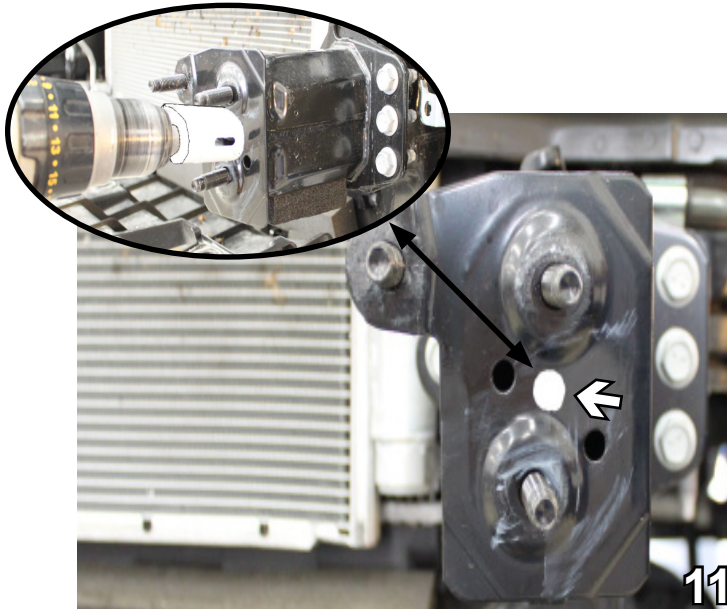

11. Using a 1 1/4" hole saw and drill, cut a hole in the front of the bumper bracket to allow nut plates to be installed in future steps.

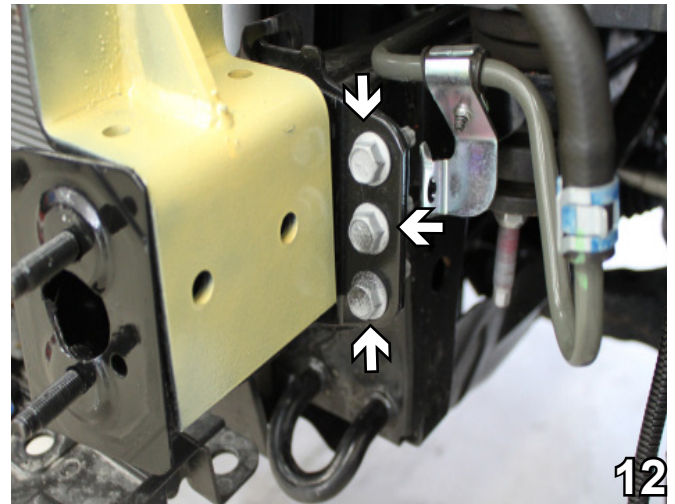

12. Using a 14MM socket, remove the three bolts from the bumper bracket. Do this on both sides. Set bolts aside to be reinstalled later, and put the baseplate into position to be installed.

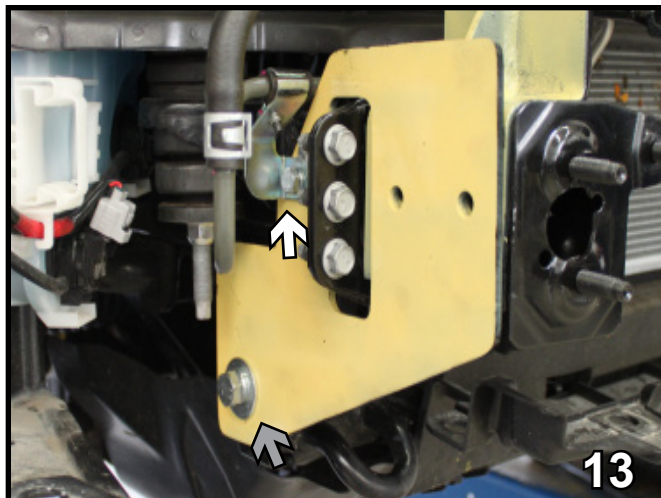

13. To install the side plate, place it over the baseplate and use a 8MM-1.25 x 30MM hex bolt with a lock washer on the outside and three flat washers with a 8MM hex nut on the inside (A, white arrow). Secure this bolt first using a 13MM socket, then use a 12MM-1.25 x 45MM hex bolt with a lock washer and a flat washer on the outside with 2 flat washers and a 12MM hex nut on the inside (B, white arrow). Tighten this bolt using a 19MM socket with Loctite Red, then remove the 8MM bolt and place it through the hose bracket and back into the hole with the lock washer on the outside and three flat washers with a 8MM hex nut on the inside. Do this on both sides of the vehicle. Replace the three 14MM bolts from step 12 after both other bolts are in place. Tighten all bolts with Loctite red.



BX3786
2011-12 Toyota 4 Runner SR5
Installation Instructions

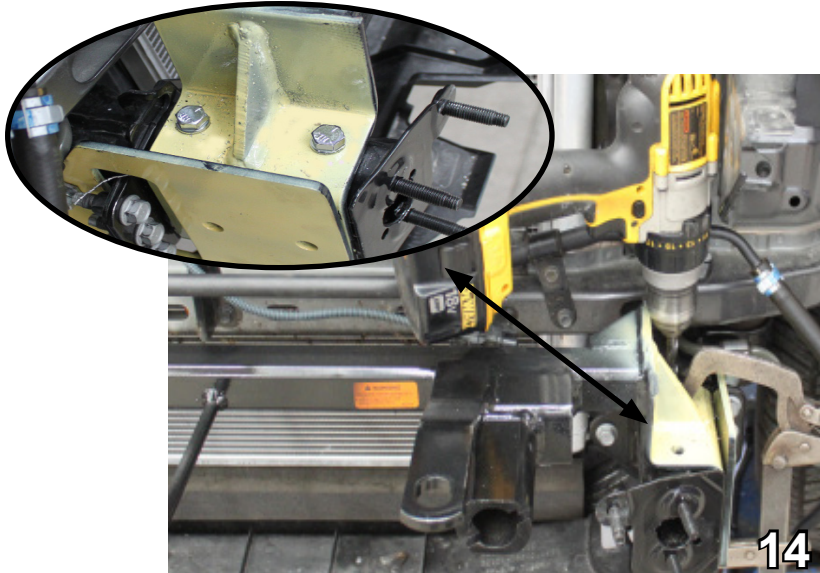

14. Using a 13/32" drill bit and a large clamp, clamp the top of the baseplate to the frame rail. Then, using the baseplate as a template, drill down into the frame rail through the top back hole on each side. Secure the baseplate with 3/8-16 x 1 1/4 hex bolts with 3/8" lock washers and 1/4 x 1 x 1 nut plates. Make sure that the baseplate is level, then tighten with Loctite Red. Do this on both sides, then drill out the top front hole and secure the baseplate with 3/8-16 x 1 1/4 hex bolts with 3/8" lock washers and a 1/4 x 1 x 1 nut plates. Do this on both sides and tighten all bolts with Loctite Red.

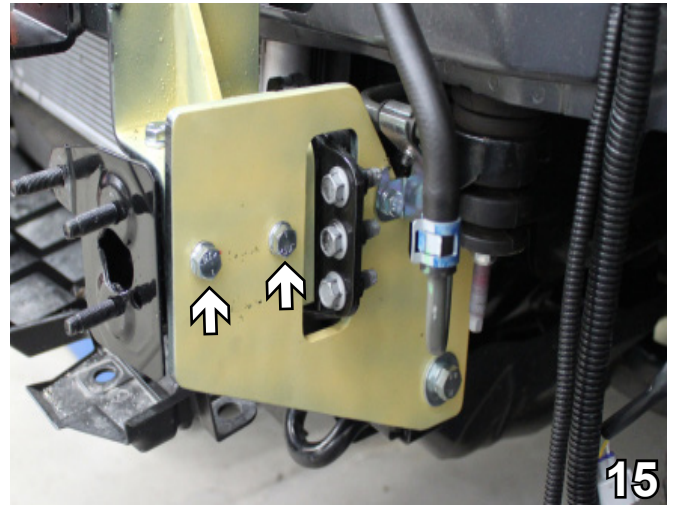

15. If necessary, use the 13/32" drill bit to clear the remaining two holes in the sideplate. Insert 3/8-16 x 1 1/2" hex bolts with 3/8" lock washers and 1/4 x 1 x 1" nut plates. Do this on both sides. Use Loctite Red on all bolts.



16. Using a utility knife, trim a rectangle from the black deflector 5 1/2" in from flush with the first large ridge in the back bottom corner. Do this on both sides of the vehicle.

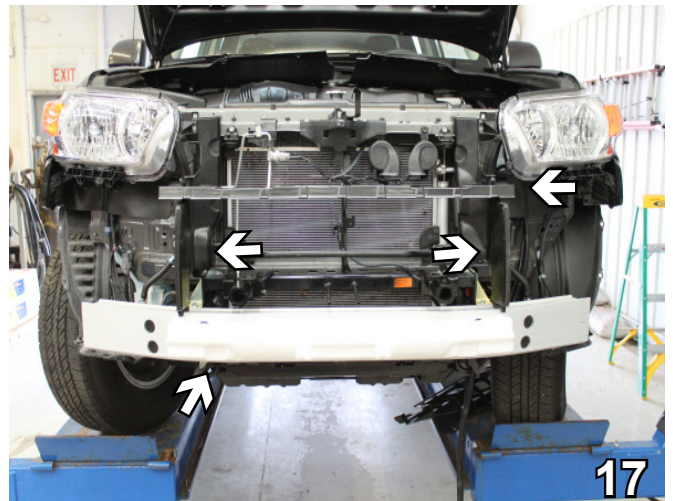

17. Reattach the black grill rail, front bumper and black plastic deflectors using the existing bolts and push pins.

BX3786
2011-12 Toyota 4 Runner SR5
Installation Instructions

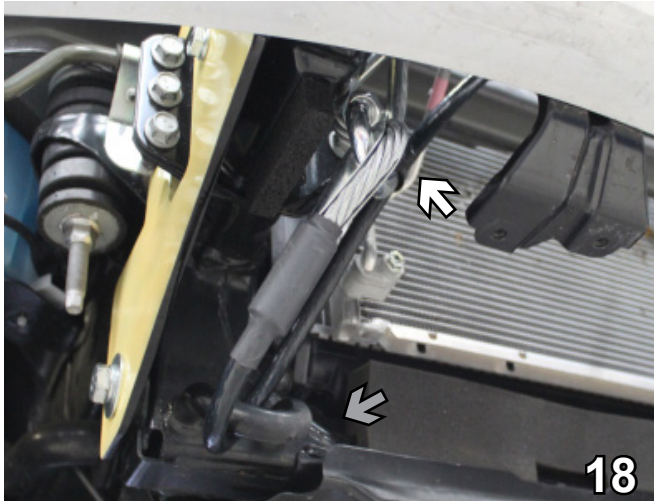

18. Attach the permanent baseplate safety cables to the provided convenience link on the baseplate (white arrow). The photo above shows the recommended installation of the permanent baseplate safety cables to frame of the vehicle (gray arrow). If the vehicle has additional options, not shown above, which interfere with mounting the permanent baseplate safety cables, secure the cable to a solid piece of the vehicle's frame as described in the instructions included with the permanent baseplate safety cables.

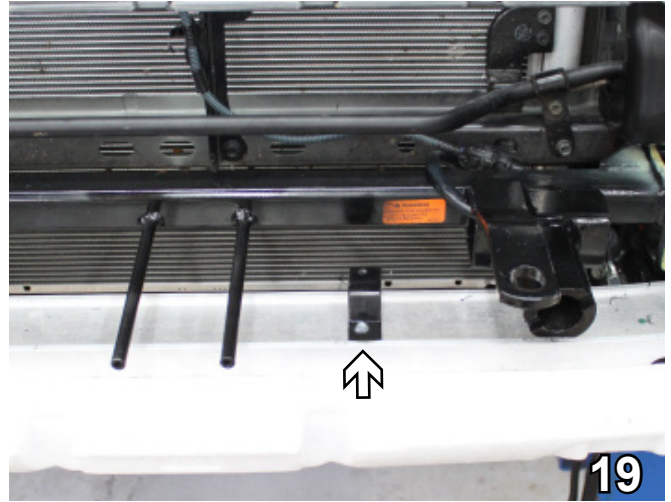

19. **Optional:** To install a breakaway switch, use a #10-16 x 1" self drilling screw and attach the breakaway mount to the front bumper as shown.



20. Align the fascia to its original position and trim the opening for the attachment tabs with a utility knife (white arrows). Do this to both sides of the vehicle. **Optional:** Attach the electrical bracket to the center of the fascia (gray arrow).



21. Reinstall the grill and fascia using the existing hardware. To reinstall the black belly pan, you have to trim the outer edges, as shown above. Tighten all bolts with Loctite Red.

BX3786
2011-12 Toyota 4 Runner SR5
Installation Instructions

CUSTOMER SERVICE COMMITMENT

Blue Ox® is committed to providing you with exceptional customer care throughout your lifetime with our products. Our team is here to assist you with any questions you may have regarding the performance of your product. Simply call (402) 385-3051 and you can speak with our technical service team.

Additionally, please visit our website to see which rallies our Destination America team will be attending. For a nominal fee, our service technician will service your towing system to ensure it's in proper working condition. Also, as a commitment to our customers, should you visit our factory, you can stay at our full service Blue Ox® campground at no charge along with enjoying a factory tour.

Again, thank you for being our customer and for the confidence you have shown in the performance of our products. It is because of customers like you we enjoy the success we have today.

© 2016 Blue Ox
One Mill Road, Industrial Park
Pender, Nebraska 68047
Phone: (402) 385-3051
Fax: (402) 385-3360
www.blueox.com

General Information

1. Ensure that your product(s) are registered online at www.blueox.com. It is crucial to register your product(s) so that you may be alerted of product offerings, updates, upgrades, maintenance and safety bulletins, and/or recalls.
2. **It is the owner's responsibility to inspect all towing equipment for cracked welds, missing or worn parts and loose bolts before each towing trip.** Be sure to use Loctite® Red on all bolts and tighten to the recommended specifications.
3. **It is the owner's responsibility to hook up all towing equipment per manufacturer's instructions/recommendations.**
4. Remove the attachment tabs when not in use (if applicable).

Notice To Baseplate Installer

1. It is YOUR responsibility to watch for:

- Oil cooler and air conditioner lines
- Electrical wires and hoses
- Missing parts or attaching points on the frame

** If the baseplate is improperly installed and is against a wire or hose, it could cause fluid leaks or electrical shorts some time after the actual baseplate installation.

Permanent Baseplate Safety Cable Installation

Permanent baseplate safety cables are strongly recommended when towing a vehicle with a tow bar. The principle function of the permanent baseplate safety cables is to prevent the towed vehicle from breaking loose in the event the connection between the frame of the towed vehicle and the baseplate fails or becomes disconnected. The cables must be connected from the baseplate to the frame rail or cross member of the vehicle's frame. The illustrations below show the possible arrangements recommended by Blue Ox®. Each permanent baseplate safety cable must have an adequate weight rating for the towing system. The weight rating of the two (2) cables together will not qualify.

Do not mount the permanent baseplate safety cables against wires, hoses or brake lines.

These permanent baseplate safety cables should remain installed as long as the baseplate is installed on the vehicle. Permanent baseplate safety cables are to be used in conjunction with, and NOT a replacement for legally required safety cables attaching the towed vehicle to the towing vehicle.

OPTION #1

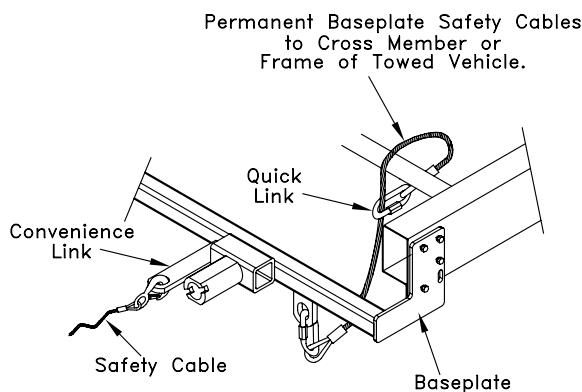

OPTION #2

