



# BLUE OX®

## BX3614 2006-08 Subaru Forester Installation Instructions

### Baseplate Installation Instructions

Serial Number

Please read BOTH these Installation Instructions and the General Instructions before attempting to install or operate this equipment.

- Blue Ox® towing products and accessories are intended to be installed by Blue Ox® Dealers who are familiar with our products and have the equipment necessary and knowledge to do "fit work". When necessary Blue Ox® Dealers can be found at [www.blueox.us](http://www.blueox.us) or by contacting our Customer Care Department at (402) 385-3051.
- Many Blue Ox® Baseplates are designed to use existing holes and hardware to mount the baseplate to the towed vehicle. Even though bolts are there, do not assume they are adequate for baseplate mounting. Always use hardware supplied in the hardware kit and existing hardware specified in the Baseplate Installation Instructions.

Attachment Tab Height: 15.5"

Attachment Tab Width: 20"

**Bolt Torque Specifications**  
Torque in Foot-Pounds per Metric Bolts

| Bolt Size | Grade 8.8 | Grade 10.9 |
|-----------|-----------|------------|
| 6MM       | 6         | 8          |
| 8MM       | 16        | 22         |
| 10MM      | 31        | 40         |
| 12MM      | 54        | 70         |
| 14MM      | 89        | 117        |

Confirm the towability and pre-towing procedures for your vehicle with the owner's manual or contact the vehicle's manufacturer for specific towing procedures. You can also contact REMCO for additional information at 1(800)228-2481.

**Bolt Torque Specifications**  
Torque in Foot-Pounds per Inch Bolts

| Bolt Size | Grade 5 | Grade 8 |
|-----------|---------|---------|
| 1/4"      | 10      | 14      |
| 5/16"     | 19      | 29      |
| 3/8"      | 33      | 47      |
| 7/16"     | 54      | 78      |
| 1/2"      | 78      | 119     |
| 5/8"      | 154     | 230     |



**WARNING**  
Failure to read and follow these instructions could result in separation of the towed vehicle from the tow bar, causing property damage, loss of towed vehicle, personal injury or death.

# BX3614 2006-08 Subaru Forester Installation Instructions

## Parts List

| Ref. No. | Qty. | Part #   | Description                                    |
|----------|------|----------|--|
| 1        | 1    | 61-6169  | Weldment, baseplate, BX3614                    |
| 2        | 6    | 61-5208  | Weldment, 3/8-16 Nut Plate, w/ 14" Wire        |
| 3        | 4    | 61-4902  | Weldment, 3/8-16 Whiz Nut, w/ 14" Wire         |
| 4        | 4    | 201-0368 | 3/8-16 x 1 1/4" Hex Bolt, Grd. 5, ZP           |
| 5        | 6    | 201-0440 | 3/8-16 x 1 1/2" Hex Bolt, Grd. 5, ZP           |
| 6        | 10   | 203-0010 | 3/8" Lock Washer, ZP                           |
| 7        | 2    | 201-0979 | #12-14 x 1" Self Drilling ScREW, ZP            |
| 8        | 2    | 201-0192 | #10-32 x 1/2" Slot, Rd. Hd. Screw              |
| 9        | 2    | 203-0054 | #10 Lock Washer                                |
| 10       | 2    | 202-0047 | #10-32 Hex Nut                                 |
| 11       | 2    | 101-5822 | Adapter, 4 Way Connector                       |
| 12       | 2    | 62-3468  | Attachment, Assembly, SF/SB (R)                |
|          | 2    | 226-0046 | Baseplate Safety Cable, 36" CL III (Not Shown) |
|          | 2    | 229-0359 | Quicklink, 3/8, ZP (Not Shown)                 |
|          | 2    | 290-0437 | Cap Plug Black, (Not Shown)                    |

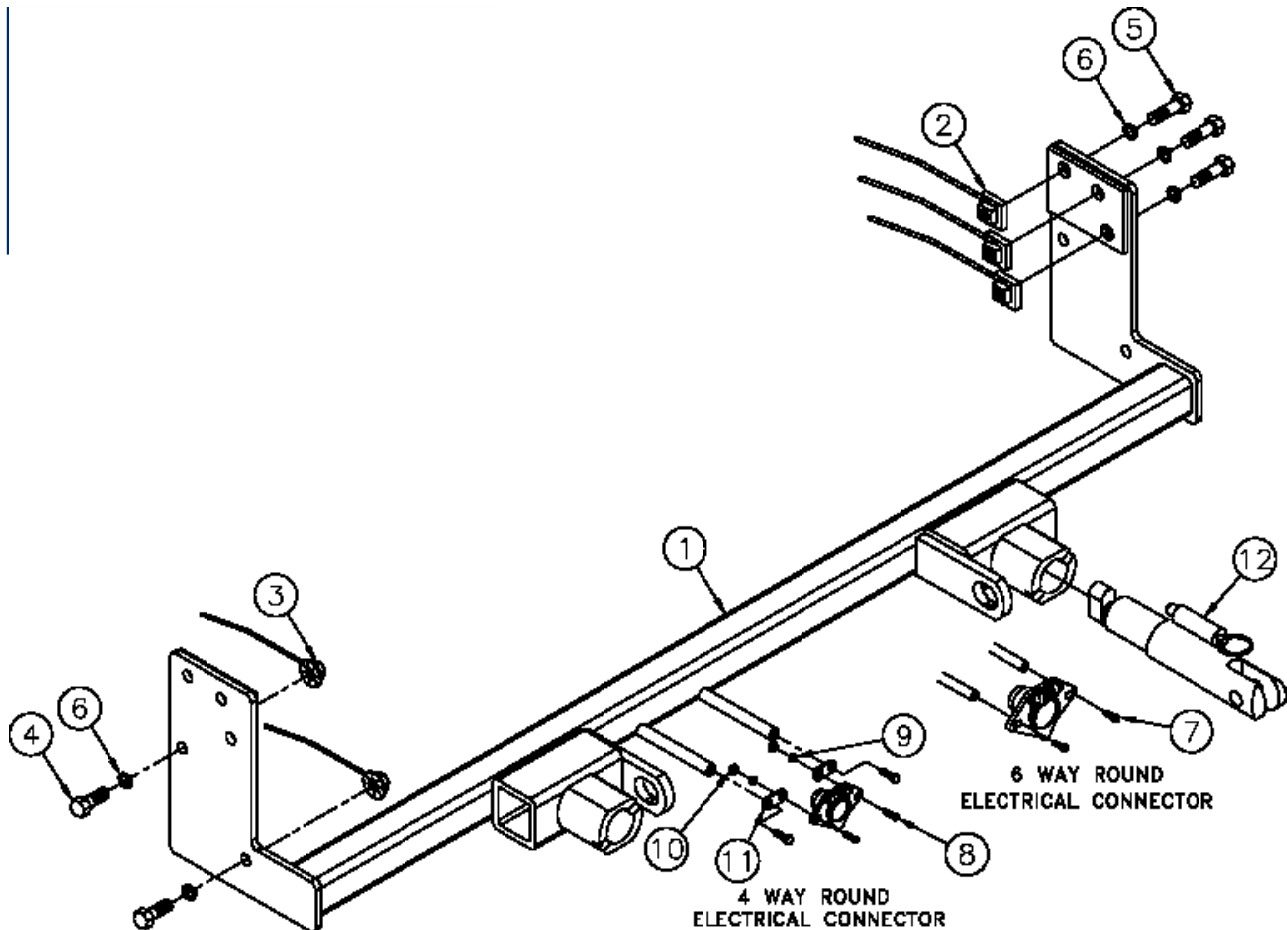

### Important:

Use only genuine factory replacement parts on your baseplate. Do **NOT** substitute homemade or non-typical parts. If a bolt is lost or in need of replacement, for your safety and the preservation of your baseplate, be sure to use a replacement bolt of the same grade (In most cases it will be Grade 5, please reference the parts list above). Replacement parts may be ordered through your nearest Blue Ox® Dealer or Distributor, or call our 24/7 Customer Care Team at (402)385-3051.

# BX3614 2006-08 Subaru Forester Installation Instructions

## Attachment Tabs:

Motorhome mount tow bars are recommended for use with this baseplate. Due to the design of the removable tabs, the RangeFinder II, Adventurer and Ambassador tow bars can not be used. The Acclaim tow bar may be used, but will not fold and on the front of the vehicle. Adapters, except the BX8833 and BX88151, can not be used with this baseplate.

## Instructions:

The front fascia, fog lights, horn brackets, Styrofoam bumper, and metal bumper are removed for the baseplate installation. Lower metal bumper cross bar will not be re-installed.

The dimensional variations between otherwise identical vehicles can be considerable. While the baseplate was designed for easy installation, it may be necessary to tailor the baseplate slightly to compensate for auto manufacturer's tolerances. These minor adjustments may include filing a hole slightly, bending electrical rods, and/ or bending end plates.

The Bx8869 Bulb and Socket Wiring Kit is recommended for this vehicle.



1. Remove six push pins from the top of the fascia. Set push pins aside to be re-installed later.



2. Remove four push pins from the under the front fascia. You will need to remove the push pin indicated by the grey arrow and pull back the webbing to expose the fourth push pin. This is done on both sides of the vehicle, the driver's side is shown. Set push pins aside to be re-installed later.

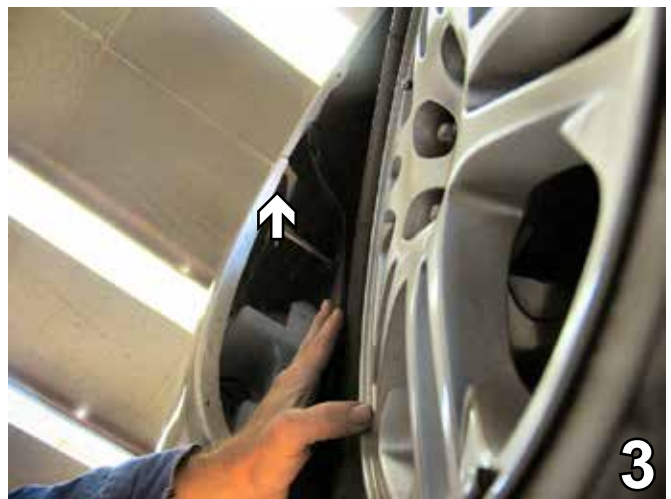

3. Remove one push pin from the top of the wheel well. This is done to both sides of the vehicle, the driver's side is shown.

# BX3614 2006-08 Subaru Forester Installation Instructions



4. On the underside of the front fascia, in the center, remove one push pin. Set it aside to be re-installed later. Unplug the fog lights, and pull the front fascia forward and set it carefully aside.

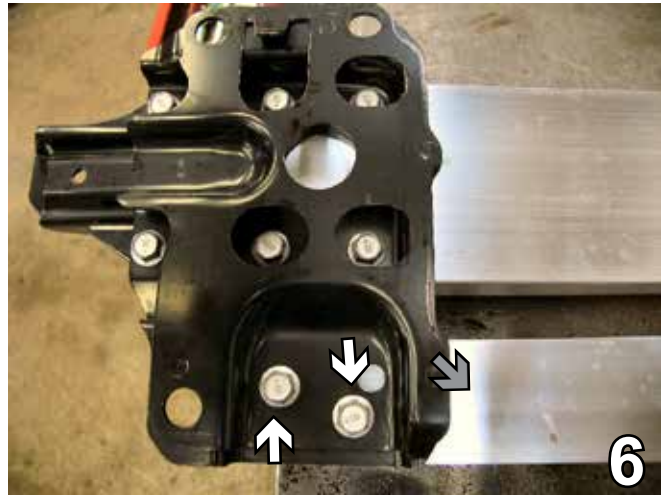

6. Set metal bumper on a flat surface, remove two lower metric bolts from the bumper bracket with a 12MM Socket. This is done on both sides of the vehicle, the driver's side is shown. Discard the lower cross bar (see grey arrow). Lower metal cross bar will NOT be re-installed.



5. Remove Styrofoam bumper. Remove three bolts from the metal bumper using a 14MM Socket. This is done on both sides of the vehicle, the driver's side is shown. Set bolts aside to be re-installed later. Pull metal bumper forward and carefully set it aside to be re-installed later.



7. Using a reciprocating saw, cut horizontally just under the lower bolt hole, approximately 1 1/8" up from the bottom of the webbing. Make a vertical cut so that the webbing is flush with the frame rail. This is done to both sides of the vehicle to open area for baseplate installation, the driver's side is shown.

# BX3614 2006-08 Subaru Forester Installation Instructions

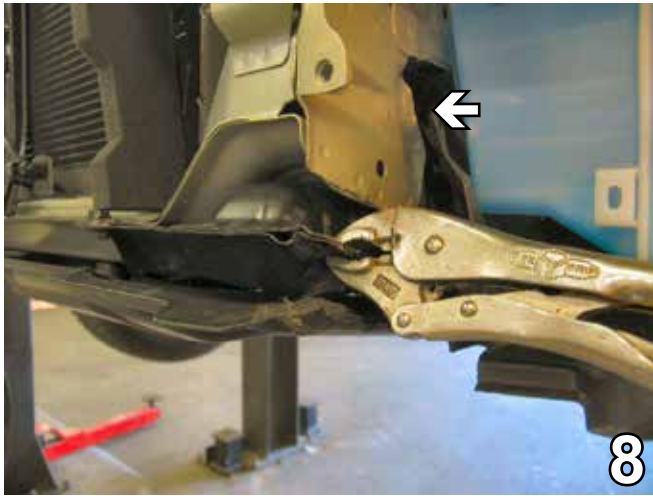

8. Ribbing should be flattened (see white arrow). Bend the ribbing on the under carriage up and in to relieve the area for baseplate installation. This is done on both sides of the vehicle, the driver's side is shown.

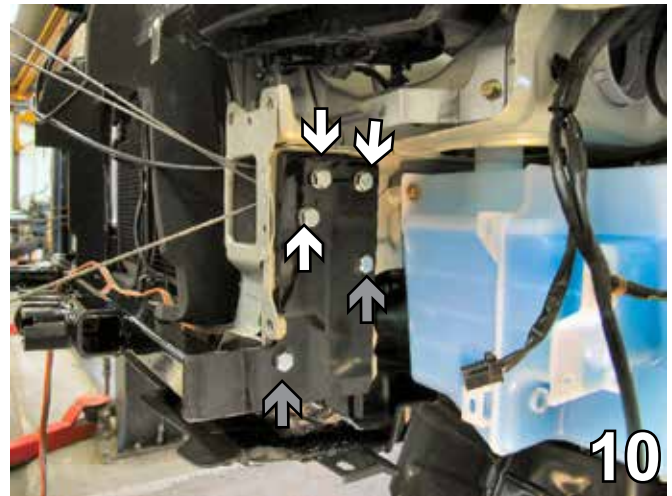

10. Align the top three holes on the endplates with the existing holes in the frame rail (see white arrows) and clamp baseplate to the frame with large vise grip. It may be necessary to ream the holes slightly to allow the bolts to clear. Drill the two lower holes in the frame with 13/32" Drill Bit (see grey arrows). This is done to both sides of the vehicle, the driver's side is shown.



9. Using a 12MM Socket, remove one metric bolt from the horn bracket. This is done on both sides of the vehicle, the driver's side is shown. Set bolts and horn bracket aside to be re-installed later.



11. Insert the 3/8-16 nut plate into the front opening of the frame rail, line up with the top three holes in the baseplate and install 3/8-16 x 1 1/2" hex bolts and 3/8" Lock Washers (see white arrows in photo 10). After bolts are tight, cut the wires from the nut plates. Install the 3/8-16 x 1 1/4 hex bolts into the two lower holes using the 3/8" Locker Washers and the 3/8-16 Whiz Nuts (see grey arrows in photo 10). After the bolts are tight cut the wire from the whiz nuts. This is done to both sides of the vehicle. The driver's side is shown.

**\*\*BE SURE TO USE LOCTITE® RED ON ALL BOLTS BEFORE TIGHTENING. TIGHTEN ALL BOLTS ACCORDING TO THE TORQUE CHART ON PAGE 1 OF THESE INSTRUCTIONS OR ON PAGE 3 OF THE BASEPLATE TOWING GENERAL INSTRUCTIONS.**

# BX3614

## 2006-08 Subaru Forester

### Installation Instructions



12. On the metal bumper (see white arrow) measure 1/4" up from the bottom and using a reciprocating saw, trim off section. This is done on both sides of the metal bumper, the driver's side is shown.

13. Re-install Styrofoam and metal bumpers according to Step 5.

14. Re-install the horn bracket according to Step 9.

15. Plug the fog lights back in.



16. Hold the front fascia up to its original position, mark and trim the bottom of the fascia approximately 1" up from the bottom on each side and in the center near tab (see arrow).

**Be sure that ALL electrical connections are plugged in properly and functioning BEFORE Installing the fascia.**

17. Reinstall front fascia according to the instructions on the previous pages (Steps 1-4).

18. Install the tow bar and safety cables according to their instructions. When demonstrating this to the customer, be sure to include all Blue Ox packages and their contents.

19. **DO NOT** substitute other devices if the tow bar pins and clips are misplaced.

#### **DEALER or INSTALLER:**

**Be certain the user receives the instructions sheets for their products.**

# BX3614 2006-08 Subaru Forester Installation Instructions



## CUSTOMER SERVICE COMMITMENT

Blue Ox is committed to providing you with exceptional customer care throughout your lifetime with our products. Our team is here to assist you with any questions you may have regarding the performance of your product. Simply call 1-800-228-9289 and you can speak with our customer care team.



Additionally, please visit our website to see which rallies our Destination America team will be attending. For a nominal fee, our service technician will service your towing system to ensure it's in proper working condition. Also as a commitment to our customers, should you visit our factory you can stay at our full service Blue Ox campground at no charge along with enjoying a factory tour.

Again thank you for being our customer and for the confidence you have shown in the performance of our products. It is because of customers like you we enjoy the success we have today.



© 2005 Blue Ox  
One Mill Road, Industrial Park  
Pender, Nebraska 68047  
Phone: (402) 385-3051  
Fax: (402) 385-3360  
www.blueox.us

# General Information

1. Ensure that your product(s) are registered online at [www.blueox.com](http://www.blueox.com). It is crucial to register your product(s) so that you may be alerted of product offerings, updates, upgrades, maintenance and safety bulletins, and/or recalls.
2. **It is the owner's responsibility to inspect all towing equipment for cracked welds, missing or worn parts and loose bolts before each towing trip.** Be sure to use Loctite® Red on all bolts and tighten to the recommended specifications.
3. **It is the owner's responsibility to hook up all towing equipment per manufacturer's instructions/recommendations.**
4. Remove the attachment tabs when not in use (if applicable).

## Notice To Baseplate Installer

### 1. It is YOUR responsibility to watch for:

- Oil cooler and air conditioner lines
- Electrical wires and hoses
- Missing parts or attaching points on the frame

\*\* If the baseplate is improperly installed and is against a wire or hose, it could cause fluid leaks or electrical shorts some time after the actual baseplate installation.

## Permanent Baseplate Safety Cable Installation

Permanent baseplate safety cables are strongly recommended when towing a vehicle with a tow bar. The principle function of the permanent baseplate safety cables is to prevent the towed vehicle from breaking loose in the event the connection between the frame of the towed vehicle and the baseplate fails or becomes disconnected. The cables must be connected from the baseplate to the frame rail or cross member of the vehicle's frame. The illustrations below show the possible arrangements recommended by Blue Ox®. Each permanent baseplate safety cable must have an adequate weight rating for the towing system. The weight rating of the two (2) cables together will not qualify.

***Do not mount the permanent baseplate safety cables against wires, hoses or brake lines.***

These permanent baseplate safety cables should remain installed as long as the baseplate is installed on the vehicle. Permanent baseplate safety cables are to be used in conjunction with, and NOT a replacement for legally required safety cables attaching the towed vehicle to the towing vehicle.

### OPTION #1

Permanent Baseplate Safety Cables to Cross Member or Frame of Towed Vehicle.

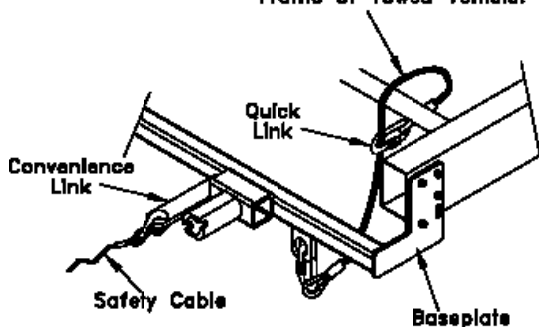

### OPTION #2

Permanent Baseplate Safety Cables to Cross Member or Frame of Towed Vehicle.

