



BX3525 2013 Suzuki SX4 Installation Instructions

Serial Number

Attachment Tab Height: 16"

Attachment Tab Width: 20-1/2"

Please read BOTH these Installation Instructions and the General Instructions prior to installing or operating this equipment.

- Blue Ox® towing products and accessories are intended to be installed by Blue Ox® Dealers who are familiar with our products and have the equipment and knowledge necessary to do "fit work". If needed, Blue Ox® Dealers can be found at www.blueox.com or by contacting our Customer Care Department at (402) 385-3051.
- Many Blue Ox® baseplates are designed to use existing holes and hardware to mount the baseplate to the towed vehicle. Even though bolts are there, do not assume they are adequate for baseplate mounting. Always use the hardware supplied in the hardware kit and existing hardware as specified in the installation instructions.

Bolt Torque Specifications
Torque in Foot-Pounds for Inch Bolts

Bolt Size	Grade 5	Grade 8
1/4"	10	14
5/16"	19	29
3/8"	33	47
7/16"	54	78
1/2"	78	119
5/8"	154	230
3/4"	257	380



Bolt Torque Specifications
Torque in Foot-Pounds for Metric Bolts

Bolt Size	Grade 8.8	Grade 10.9
6MM	6	8
8MM	16	22
10MM	31	40
12MM	54	70
14MM	89	117
16MM	161	230
18MM	222	318

If the front of your vehicle looks different than this, please contact us at (402)385-3051.

Reference your vehicle owner's manual for manufacturer's towing specifications.

! WARNING

Failure to read and follow these instructions could result in separation of the towed vehicle from the tow bar, causing property damage, loss of towed vehicle, personal injury or death.

BX3525
2013 Suzuki SX4
Installation Instructions

Instruction Notes: The fascia, metal bumper, headlights and washer reservoir are removed and reinstalled for the baseplate installation. Some drilling and trimming is required.

Place all components that are removed on a flat, sturdy surface. All items will be reinstalled unless otherwise noted after the baseplate is installed.

The dimensional variations between otherwise identical vehicles can be considerable. While the baseplate was designed for easy installation, it may be necessary to tailor the baseplate slightly to compensate for vehicle manufacturer's tolerances.

The BX8869 Tail Light Wiring Kit is recommended for this vehicle.

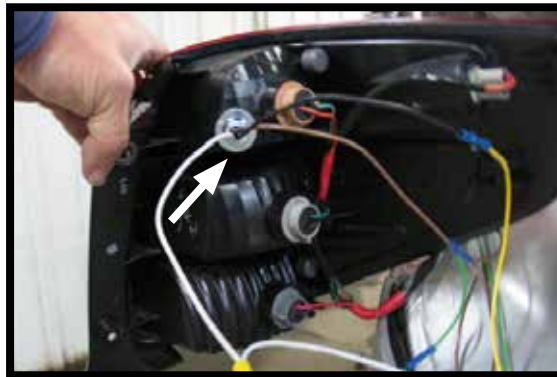

Drill a hole according to the tail
light wiring kit instructions.

NOTICE

- Handling of some cosmetic parts when installing this product may require the use of protective covers, rags, specialty tools, etc. to prevent damage.
- When using power drills be aware of the dangers of torque and drill bit length.
- When using a reciprocating saw be aware of objects behind the cutting surface.
- Use a good quality paint to spray cut edges of frame to prevent rusting.
- Be sure that **ALL** electrical connections are plugged in and accessories are functioning properly before reinstalling the fascia.
- Do not use the towed vehicle for storing luggage, equipment, etc. This may cause you to exceed the towing capacity of the tow bar, baseplate and its accessories.
- Be sure to use Loctite® Red on all bolts before tightening. Tighten all bolts according to the torque chart provided.
- Dealer or installer be certain the user receives these instruction sheet.
- If the baseplate is in an accident, it must be replaced. **DO NOT** use it again! An accident can cause unseen damage and using it again could result in more damage or serious injury. **DO NOT** use the baseplate if it is damaged or missing parts.

BX3525 2013 Suzuki SX4 Installation Instructions

Tools Required

Large Vise Grip
 Utility Knife
 Phillips Screwdriver
 Torque Wrench
 Drill
 Reciprocating Saw
 Tape Measure
 Loctite® RED
 13/32" Drill Bit
 1-1/4" Hole Saw
 10MM Socket
 12MM Socket
 7/16" Socket
 7/16" Wrench
 9/16" Socket
 9/16" Wrench

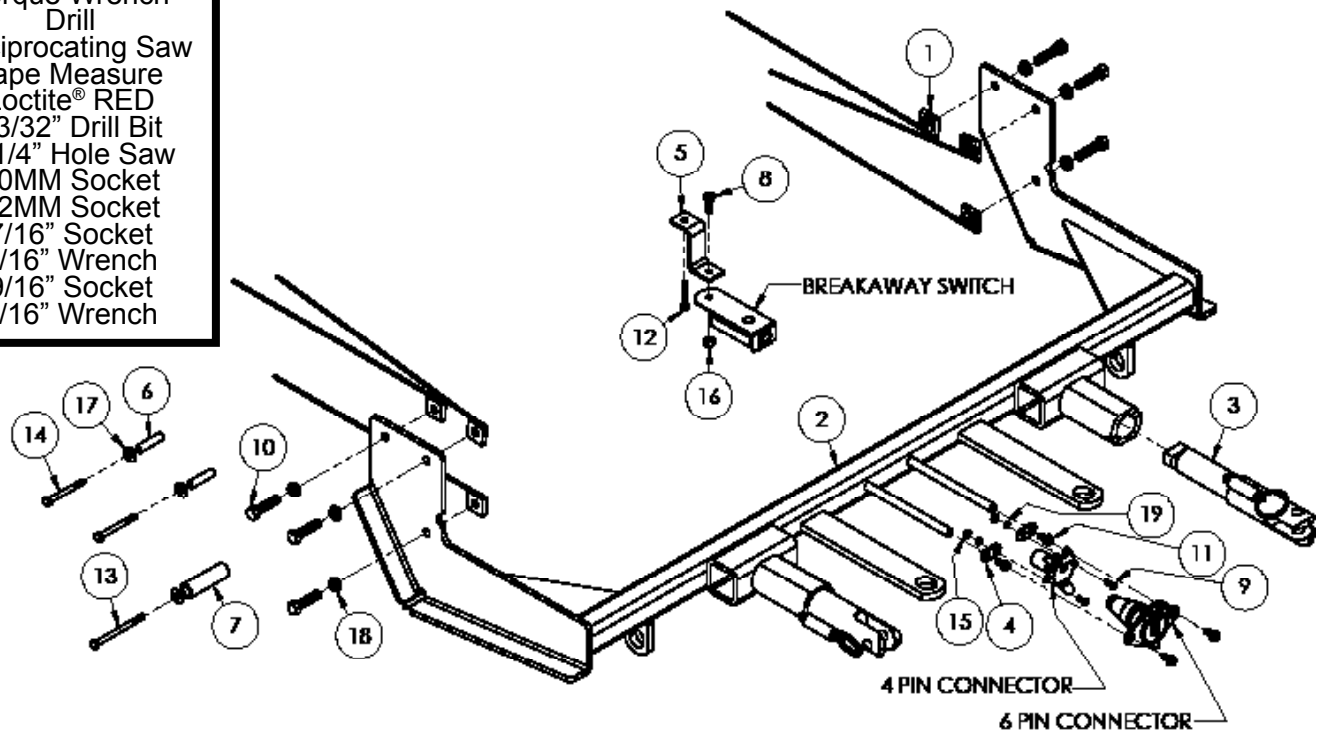

Item No.	Part No.	Description	Qty.
1.....	61-5208.....	3/8"-16 Nut Plate w/ 14" Wire.....	6
2.....	61-7208.....	BX3525 Baseplate.....	1
3.....	62-3469.....	Attachment Tab Assembly with Hole.....	2
4.....	101-5822.....	4 Way Connector Adapter.....	2
5.....	102-7056.....	Breakaway Bracket.....	1
6.....	106-0369.....	3/8" Pipe x 1-1/2"L.....	2
7.....	107-3087.....	3/4" Tube x 2-1/2"L.....	1
8.....	201-0050.....	1/4"-20 x 3/4" Hex Head Bolt, Grade 5, ZP.....	1
9.....	201-0192.....	#10-32 1/2" Round Slotted Head Screw.....	2
10.....	201-0440.....	3/8"-16 x 1-1/2" Hex Head Bolt, Grade 5, ZP.....	6
11.....	201-0979.....	#12-14 x 1" Self Drilling Screw, ZP.....	2
12.....	201-0654.....	#10-16 x 1" Self Drilling Screw, ZP.....	1
13.....	201-0709.....	6MM-1MM x 80MM Hex Head Bolt, Grade 8.8, ZP.....	1
14.....	201-0798.....	6MM-1MM x 60MM Hex Head Bolt, Grade 8.8, ZP.....	2
15.....	202-0047.....	#10-32 Hex Nut.....	2
16.....	202-0102.....	1/4"-20 Hex Nylon Nut, ZP.....	1
17.....	203-0001.....	1/4" Flat Washer, ZP.....	3
18.....	203-0010.....	3/8" Lock Washer, ZP.....	6
19.....	203-0054.....	#10 Lock Washer, ZP.....	2
20.....	226-0046(not shown).....	Class III Safety Cables.....	2
21.....	229-0359(not shown).....	3/8" Quicklink, ZP.....	2
22.....	290-0437(not shown).....	Black Cap Plug Receiver.....	2

Important:

Use only genuine factory replacement parts on your baseplate. Do **NOT** substitute homemade or non-typical parts. If a bolt is lost or in need of replacement, for your safety and the preservation of your baseplate, be sure to use a replacement bolt of the same grade (In most cases it will be Grade 5, please reference the parts list above). Replacement parts may be ordered through your nearest Blue Ox® Dealer or Distributor. Failing to follow and/or altering these installation instructions in either installation or required equipment will void the manufacturer's warranty. Towing behind a non-motorized vehicle will void the warranty.

BX3525
2013 Suzuki SX4
Installation Instructions



1. Along the top edge of the fascia, remove the four (4) bolts with a 10MM socket or a Phillips screw driver.

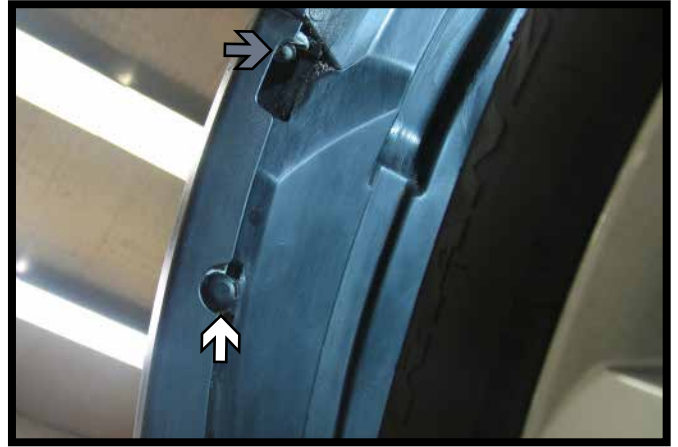

2. In the wheel well, remove the pushpin (white) and the Phillips head screw (gray). Do this to both sides of the vehicle.



3. On the bottom side of the fascia, remove six (6) Phillips screws from both corners of the vehicle. There are three (3) on each side (3A). Towards the center, remove the one (1) Phillips head screw and the two (2) bolts with a 10MM socket and/or Phillips screw driver (3B).

BX3525
2013 Suzuki SX4
Installation Instructions



4. To remove fascia, pull it out to the side and forward a little bit. Once fascia is forward there are two clips on top to be removed by pushing in on the fascia and lifting up on the clips to get them over the stops. Set fascia aside.

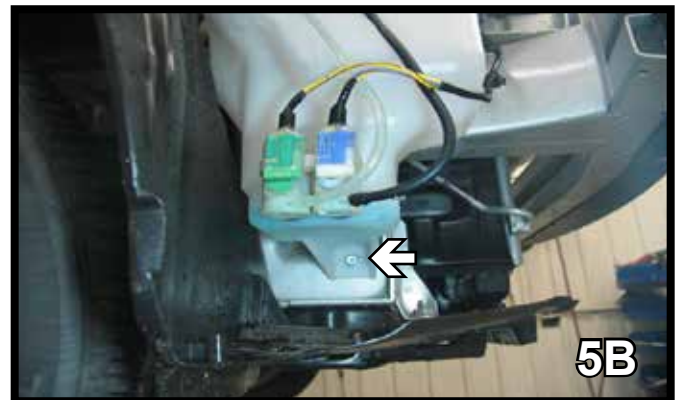
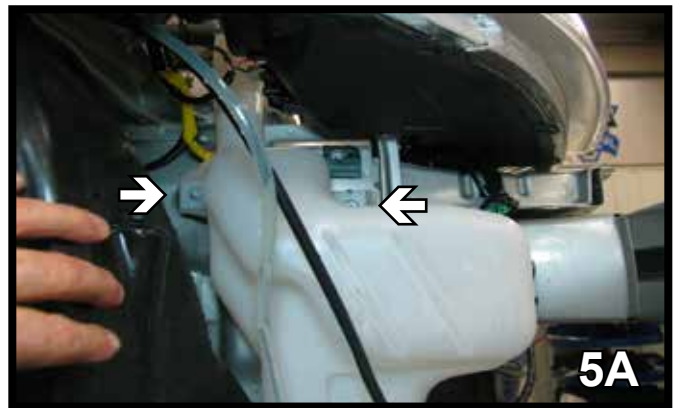

5. Using a 10MM socket, remove two (2) bolts on the topside of the washer reservoir (5A) and one (1) bolt on the bottom side (5B). Plug the hoses and disconnect the electrical.

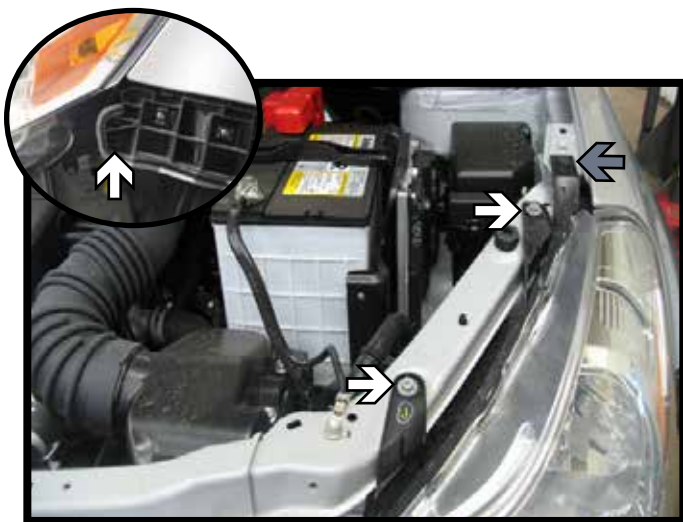

6. Using a 10MM socket, remove two (2) bolts on top and one metric bolt on the bottom of the headlight assembly (white). There is also a pushpin on top that needs to be removed (gray). Pull the headlight assembly forward to remove and disconnect the electrical connections. Do this to both sides of the vehicle.

BX3525
2013 Suzuki SX4
Installation Instructions



7. Disconnect wire connections from the right and left side of the bumper, as well as the sensors located underneath the bumper.

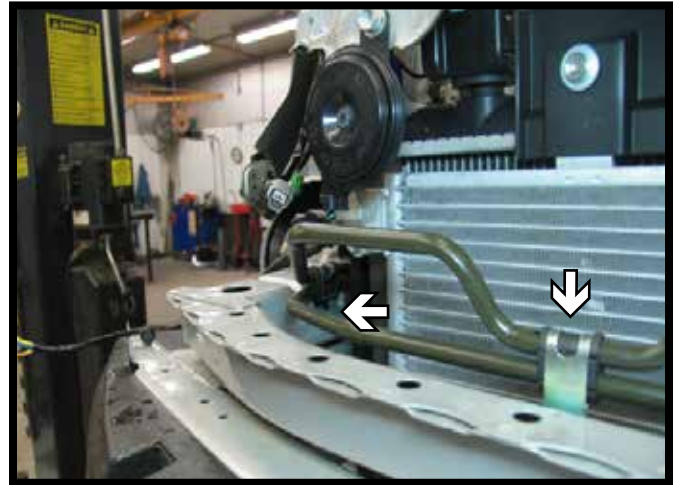

8. Using a 10MM socket, remove two (2) bolts from the coolant line. One (1) bolt is located on the back side of the bumper and the other is located on the inside of the bumper on the right side.

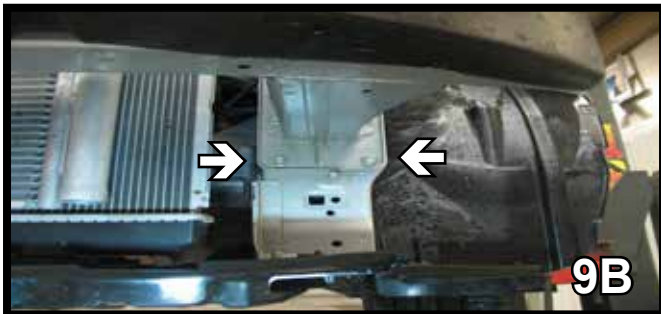
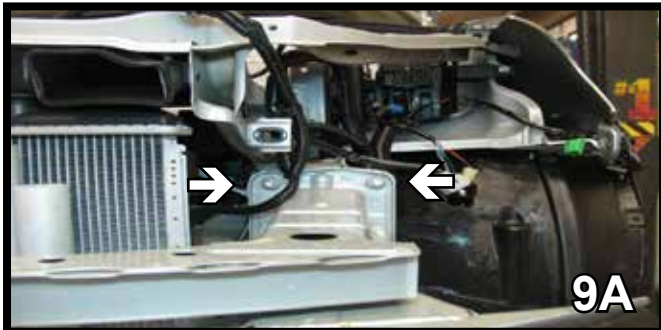

9. Using a 12MM socket, remove two (2) bolts from the top and bottom of the bumper. Do this to both sides of the vehicle.



10. Using a marker, make a horizontal line just below the metal bumper. Then with a reciprocating saw, cut into the edge of the frame well and follow it down to the bottom and out. It's very important to follow the frame well because it offsets down at the top. You will then be able to remove that whole portion of the frame well webbing. Do this to both sides of the vehicle.

BX3525
2013 Suzuki SX4
Installation Instructions

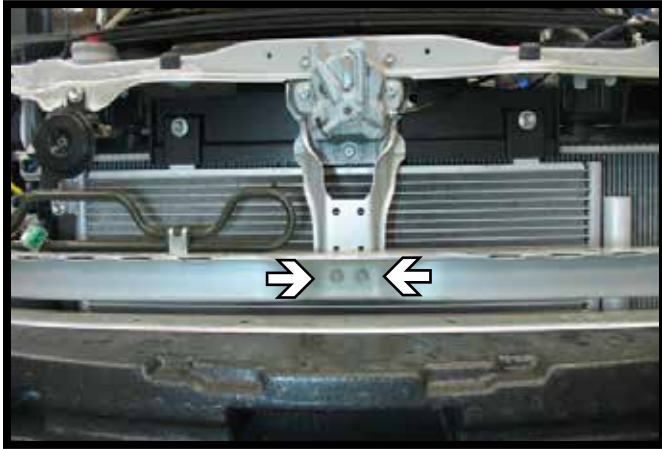

11. Using a 10MM socket, remove two (2) bolts from the center of the bumper. Carefully remove bumper and set aside.

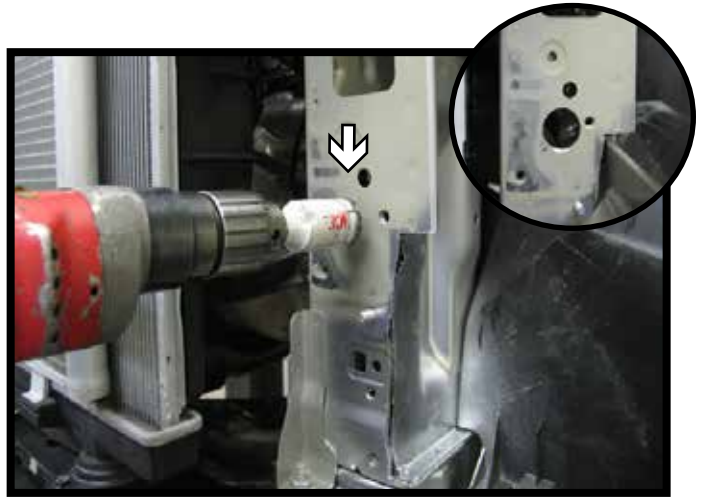

12. Using a 1-1/4" hole saw, drill a hole just to the side of the threaded hole so you can get into the lower portion of the frame to position a nut plate. Do this to both sides of the vehicle.

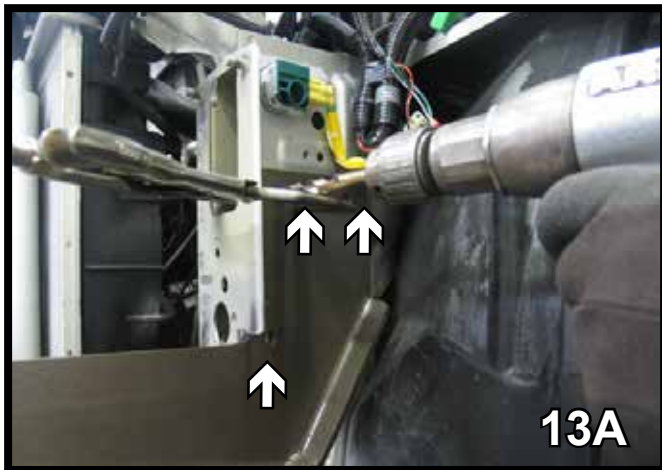

13A

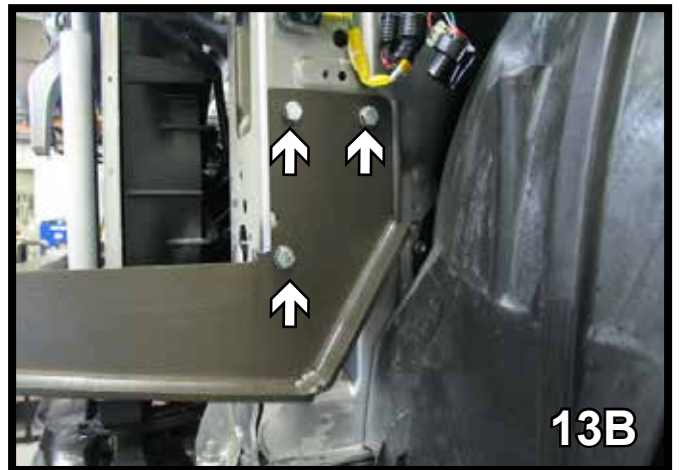

13B

13. Take the baseplate and slide it up to the very top edge of where the frame has doubled up and clamp it into place. When positioned in place, drill three (3) holes using a 13/32" drill bit. Then insert a 3/8"-16 x 1-1/2" bolts with a 3/8" lock washers into these holes and tighten to 3/8"-16 nut plates. Do this to both sides of the vehicle.

BX3525
2013 Suzuki SX4
Installation Instructions

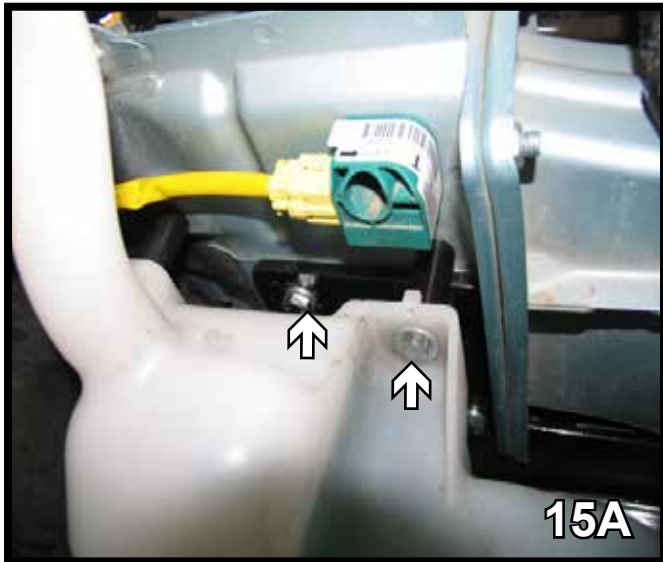

15. Reinstall the washer reservoir using 6MM -1.0 x 30MM hex bolts, 1/4" flat washers and 1 1/2" pipes in the two top holes (15A). In the bottom hole, use a 6MM-1MM X 80MM hex bolt, 1/4" flat washer and 2 1/2" tube (15B).



16. Attach the permanent baseplate safety cables to the provided convenience link on the baseplate. The photo above shows the recommended installation of the cables to frame of vehicle. Additional options may interfere with suggested mounting; in this case, secure the cables to a solid piece of the frame as described in the instructions included with the permanent baseplate safety cables. Be sure the safety cables do not rub against any hoses or moving parts. Do this on **BOTH** sides of the vehicle.

BX3525
2013 Suzuki SX4
Installation Instructions

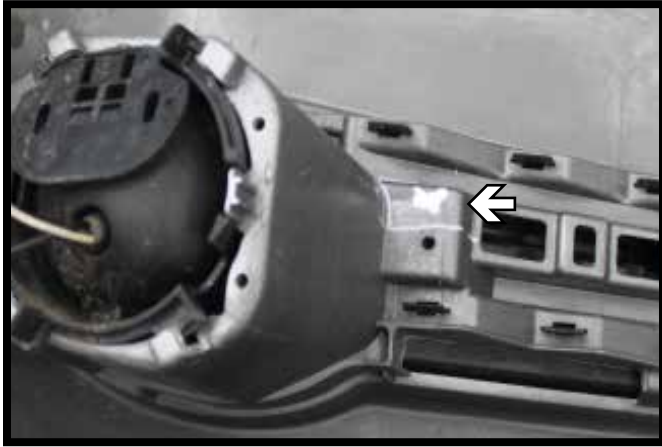

17. On the backside of fascia, trim the fog light housing as shown for clearance around the baseplate. Do this on both sides of the fascia.



18. Align the fascia to its original position and if necessary trim the opening in the grille for the attachment tabs. Do this to both sides of the vehicle. Reinstall the bumper, headlights and fascia.

CUSTOMER SERVICE COMMITMENT

Blue Ox® is committed to providing you with exceptional customer care throughout your lifetime with our products. Our team is here to assist you with any questions you may have regarding the performance of your product. Simply call (402) 385-3051 and you can speak with our customer care team.

Additionally, please visit our website to see which rallies our Destination America team will be attending. For a nominal fee, our service technician will service your towing system to ensure it's in proper working condition. Also, as a commitment to our customers, should you visit our factory, you can stay at our full service Blue Ox® campground at no charge along with enjoying a factory tour.

Again, thank you for being our customer and for the confidence you have shown in the performance of our products. It is because of customers like you we enjoy the success we have today.

© 2012 Blue Ox
One Mill Road, Industrial Park
Pender, Nebraska 68047
Phone: (402) 385-3051
Fax: (402) 385-3360
www.blueox.com

General Information

1. Ensure that your product(s) are registered online at www.blueox.com. It is crucial to register your product(s) so that you may be alerted of product offerings, updates, upgrades, maintenance and safety bulletins, and/or recalls.
2. **It is the owner's responsibility to inspect all towing equipment for cracked welds, missing or worn parts and loose bolts before each towing trip.** Be sure to use Loctite® Red on all bolts and tighten to the recommended specifications.
3. **It is the owner's responsibility to hook up all towing equipment per manufacturer's instructions/recommendations.**
4. Remove the attachment tabs when not in use (if applicable).

Notice To Baseplate Installer

1. It is YOUR responsibility to watch for:

- Oil cooler and air conditioner lines
- Electrical wires and hoses
- Missing parts or attaching points on the frame

** If the baseplate is improperly installed and is against a wire or hose, it could cause fluid leaks or electrical shorts some time after the actual baseplate installation.

Permanent Baseplate Safety Cable Installation

Permanent baseplate safety cables are strongly recommended when towing a vehicle with a tow bar. The principle function of the permanent baseplate safety cables is to prevent the towed vehicle from breaking loose in the event the connection between the frame of the towed vehicle and the baseplate fails or becomes disconnected. The cables must be connected from the baseplate to the frame rail or cross member of the vehicle's frame. The illustrations below show the possible arrangements recommended by Blue Ox®. Each permanent baseplate safety cable must have an adequate weight rating for the towing system. The weight rating of the two (2) cables together will not qualify.

Do not mount the permanent baseplate safety cables against wires, hoses or brake lines.

These permanent baseplate safety cables should remain installed as long as the baseplate is installed on the vehicle. Permanent baseplate safety cables are to be used in conjunction with, and NOT a replacement for legally required safety cables attaching the towed vehicle to the towing vehicle.

OPTION #1

Permanent Baseplate Safety Cables to Cross Member or Frame of Towed Vehicle.

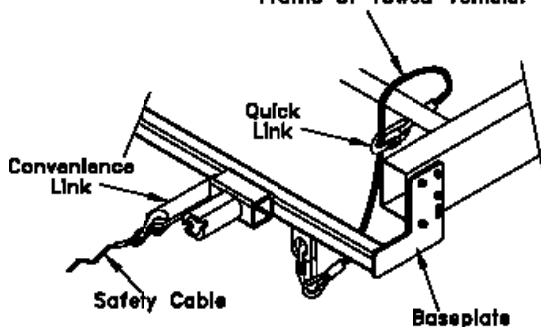

OPTION #2

Permanent Baseplate Safety Cables to Cross Member or Frame of Towed Vehicle.

