



BLUE OX®

Baseplate Installation Instructions

BX2911

2008 Lexus IS250 Installation Instructions

Serial Number

Please read **BOTH** these Installation Instructions and the General Towing Instructions before attempting to install or operate this equipment.

1. Blue Ox® towing products and accessories are intended to be installed by Blue Ox® Dealers who are familiar with our products and have the equipment and knowledge to do “fit work.” When necessary, Blue Ox® Dealers can be found at www.blueox.com or by contacting our Customer Care Department at (402) 385-3051.

Attachment Tab Height: 13 3/4”

Attachment Tab Width: 24”

2. Many Blue Ox® Baseplates are designed to use existing holes and hardware to mount the baseplate to the towed vehicle. Even though bolts are there, do not assume they are adequate for baseplate mounting. Always use hardware supplied in the hardware kit or existing hardware specified in the Baseplate Towing Installation Instructions.

Bolt Torque Specifications

Torque in Foot-Pounds for Metric Bolts

Bolt Size	Grade 8.8	Grade 10.9
6MM	6	8
8MM	16	22
10MM	31	40
12MM	54	70
14MM	89	117

Confirm the towability and pre-towing procedures for your vehicle with the owner’s manual or contact the vehicle’s manufacturer for specific towing procedures.

Bolt Torque Specifications

Torque in Foot-Pounds for Inch Bolts

Bolt Size	Grade 5	Grade 8
1/4”	10	14
5/16”	19	29
3/8”	33	47
7/16”	54	78
1/2”	78	119
5/8”	154	230



If the front of your vehicle looks different than this, call us at (402) 385-3051.

! WARNING

Failure to read and follow these instructions could result in separation of the towed vehicle from the tow bar, causing property damage, loss of towed vehicle, personal injury or death.

BX2911

2008 Lexus IS250

Installation Instructions

Tools Required

10MM Socket
 17MM Socket
 9/16" Socket/Wrench
 Diagonal Cutters
 Large Vise Grip
 Hammer
 Reciprocating Saw
 Drill
 13/32" Drill Bit
 Flat Screw Driver
 Phillips Screw Driver
 Loctite® RED

ITEM NO.	PART NUMBER	DESCRIPTION	QTY.
1	61-6910	WLDMT, BP, BX2911	1
2	61-5208	WLD, NUT PLATE, 1/4 X 1 X 1 (3/8-16)w/ 1/4" WIRE	12
3	62-3468	ATT TAB ASSY, REM, SF/SB, 1 HOLE	1
4	201-0368	3/8-16 X 1 1/4 HEX HEAD BOLT	12
5	203-0010	3/8" LOCK WASHER, ZP	12
6	201-0979	#12-14 x 1" SELF DRILLING SCREW, ZP	2
7	201-0192	#10-32-1/2" SLOT, ROUND HEAD SCREW	2
8	203-0054	#10-32 LOCK WAHSER, ZP	2
9	202-0047	#10-32 HEX NUT	2
10	101-5822	ADAPTER, 4 WAY CONNECTOR	2
11	201-0050	1/4-20 X 3/4 HEX BOLT, GRD. 5, ZP	1
12	202-0102	1/4-20 HEX NYL NUT, ZP	1
13	201-0655	6MM-1.0 X 30MM HEX BOLT, GRD. 8.8, ZP	1
14	203-0001	1/4" FLAT WASHER, ZP	1
15	201-0654	#10-16 X 1" SELF DRILLING SCREW, ZP	1
16	102-7056	BREAKAWAY BRKT.	1

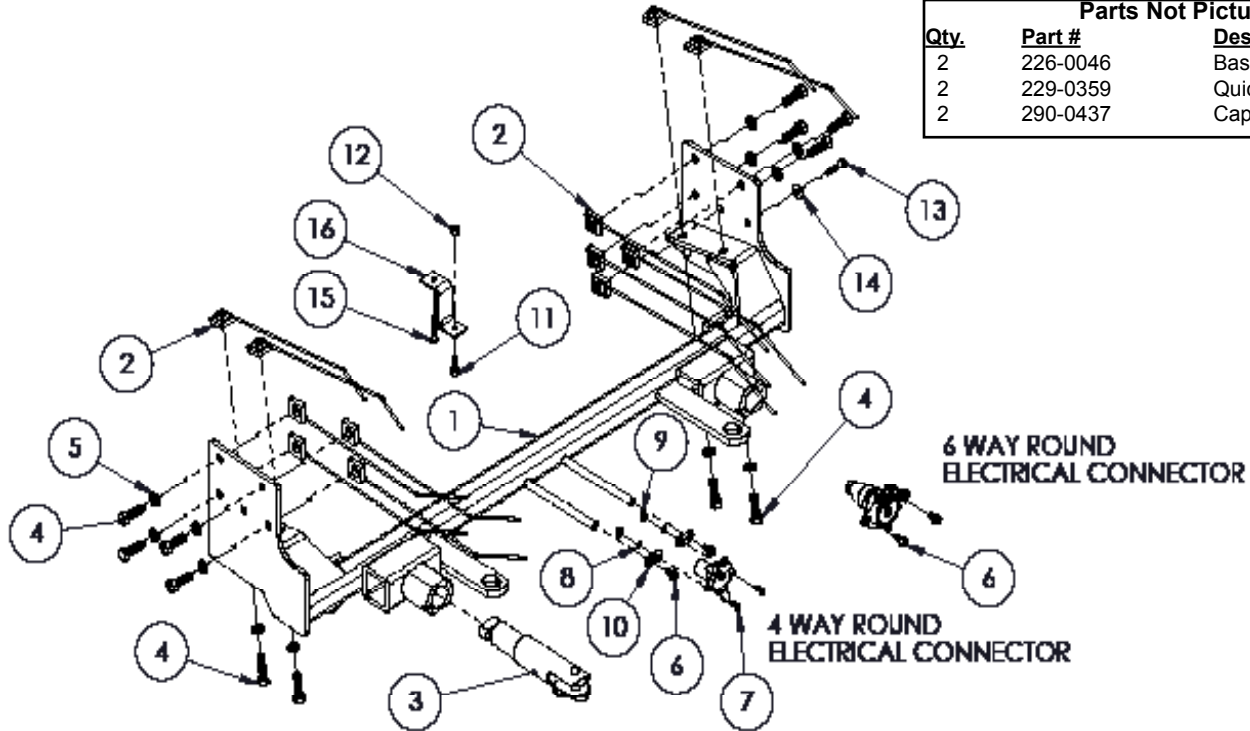

Parts Not Pictured:		
Qty.	Part #	Description
2	226-0046	Baseplate Safety Cables
2	229-0359	Quicklink, 3/8, ZP
2	290-0437	Cap Plug, Black

Important:

Use only genuine factory replacement parts on your baseplate. Do **NOT** substitute homemade or non-typical parts. If a bolt is lost or in need of replacement, for your safety and the preservation of your baseplate, be sure to use a replacement bolt of the same grade (In most cases it will be Grade 5, please reference the parts list above). Replacement parts may be ordered through your nearest Blue Ox® Dealer or Distributor. Failing to follow and/or altering these installation instructions in either installation or required equipment will void the manufacturer's warranty. Towing behind a non-motorized vehicle will void the warranty.

BX2911

2008 Lexus IS250

Installation Instructions

Vehicle Weight: Due to the design of the removable tabs, the RangeFinderII tow bar can not be used. Adapters, except the BX8833 and BX88151, can not be used with this baseplate.

Installation Notes: The fascia, bumper, splash guard, belly pan, fog lights, temperature sensor, air dams, air baffles and horn are removed and reinstalled during installation of the baseplate. Drilling is required. Trimming of the fascia and air dam is required.

The dimensional variations between otherwise identical vehicles can be considerable. While the baseplate was designed for easy installation, it may be necessary to tailor the baseplate slightly to compensate for auto manufacturer's tolerances. These minor adjustments may include filing a hole slightly, bending electrical rods and/ or bending end plates.

Installation Instructions:



1. On the top of the fascia, remove push pins with a flat screwdriver. Do this on both sides. Set push pins aside to be reinstalled later. Remove plastic engine cover. Set aside to be reinstalled later.



2. On top of the fascia, inside of the headlight, remove Phillips screw and pushpin. Do this on both sides. Set push pins and screws aside to be reinstalled later.

Handling of some cosmetic parts when installing this product may require the use of protective covers, rags, specialty tools, etc. to prevent damage.



3. Just above the vehicle's emblem, remove bolt from vehicle support using a 10MM socket. Set bolt aside to be reinstalled later.



4. To remove the bumper, with a 10MM socket, remove 8 bolts from the underside of the fascia. Set bolts and bumper aside to be reinstalled later.

BX2911

2008 Lexus IS250

Installation Instructions

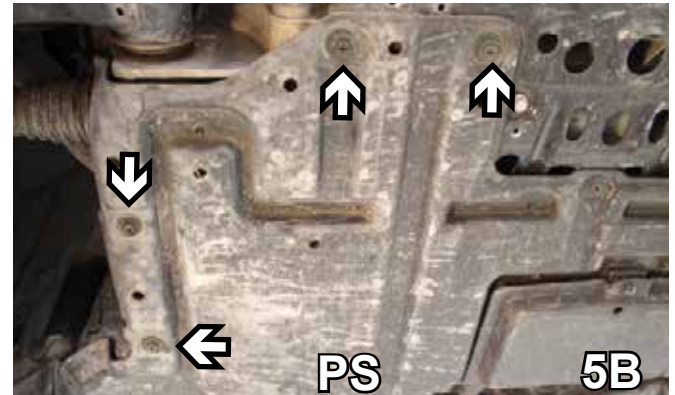
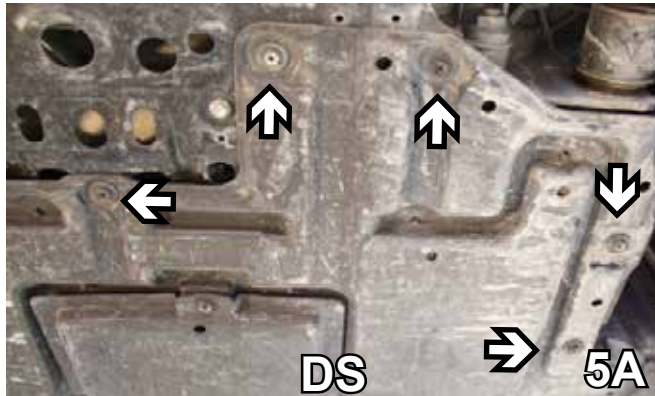

5. To remove the splash guard, with a 10MM socket, remove 9 bolts. Set splash guard and bolts aside to be reinstalled later.



6. Just forward of the front tire, lift up the wheel well cover, use a 10MM socket to remove the screw. Do this to both sides of the vehicle. Set screws aside to be reinstalled later.



7. Forward of the front tire, using a flat screw driver, turn the two screws to the horizontal position and they will release. Do this to both sides of the vehicle. Set screws aside to be reinstalled later.



8. Pull fascia forward to remove. On driver's side, disconnect sensor from fog light. After disconnection, remove fog lights from both sides of the vehicle's fascia. Set aside to be reinstalled later.

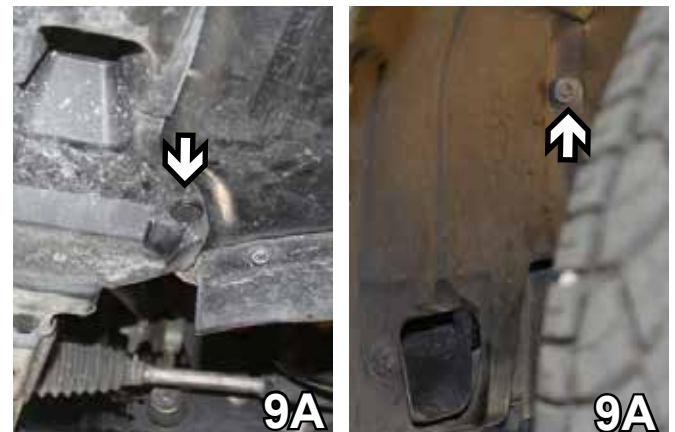

9. At the bottom edge of the fascia, remove 1 push pin (9A) and 4 metric bolts (9B) along inside rim of fascia with 10MM socket. Set push pin and bolts aside to be reinstalled later.

BX2911

2008 Lexus IS250

Installation Instructions



10. Detach and remove bellypan from underneath the metal bumper. Set aside to be reinstalled later.



11. Beneath metal bumper, remove bolt for temperature sensor bracket with 10MM socket. Detach sensor from bracket. Set aside bracket and bolt to be reinstalled later.



12. To remove washer fluid reservoir, with a 10MM socket, remove bolt in back (12A), in front and to the left of the reservoir (12B) as well as on the topside of the reservoir just above headlight (12C). Disconnect electrical, and plug fluid lines and set aside to be reinstalled later. **NOTE:** Two of the Three existing bolts will be replaced with bolts provided (12A and 12B).



13. To remove the air baffles, with a 10MM socket, in front of the tire, remove bolt (13A), under the air baffle, remove 2 bolts (13B) and unsnap the air baffle at the bottom of the metal bumper (13C). Do this on both sides. Pull down air baffles to remove and set aside air baffles and bolts to be reinstalled later.

BX2911
2008 Lexus IS250
Installation Instructions

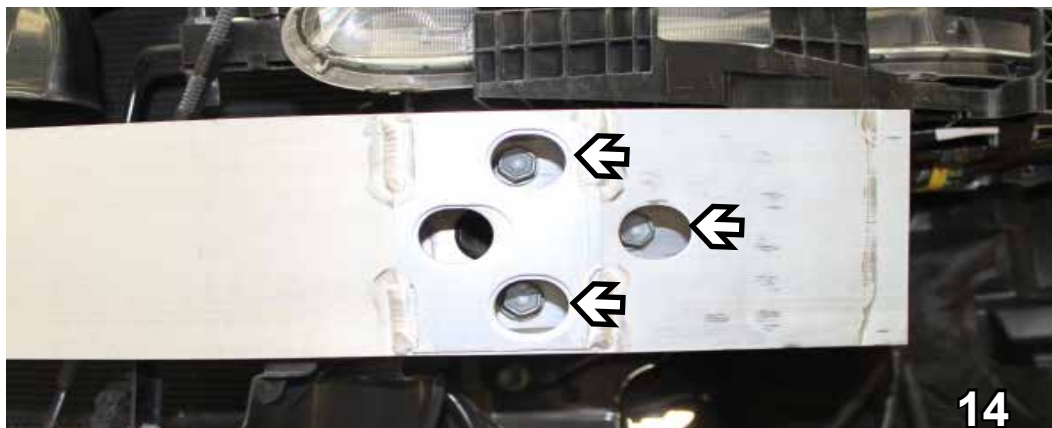

14. With a 17MM socket, remove 3 bolts from metal bumper. Do this to both sides. Set aside metal bumper and bolts to be reinstalled later.



15. With reciprocating saw, on the passenger's side only, trim metal next to radiator flush with the front of the bracket (15A). After trimming is completed, tap remaining piece toward radiator to make flush and allow for baseplate mounting (approximately 1/4") (15B).

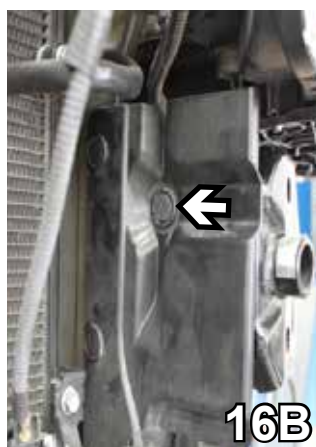
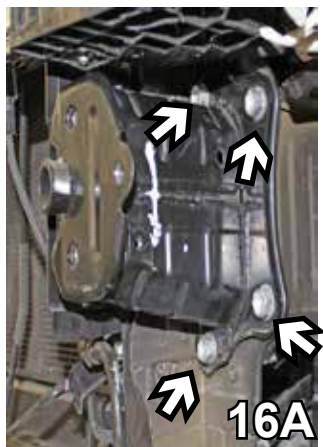

16. Remove horns on both sides of the vehicle. Using a 17MM socket, remove 4 bolts attaching horn (13A) and 1 push pin (13B). Do this on both sides. Set aside horns, bolts and push pins to be reinstalled later.



17. Lay baseplate in upright position on a smooth work surface (yellow is used on this baseplate for demonstrative purposes only). Anchor baseplate to work surface with vice grips.

BX2911

2008 Lexus IS250

Installation Instructions

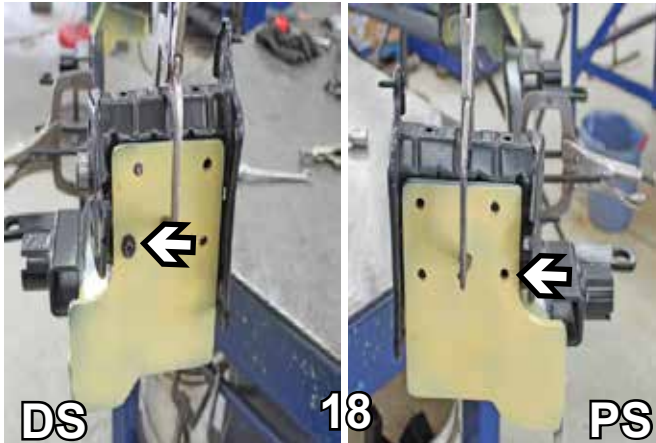

18. Using baseplate as a template and existing bolt hole on driver's side horn, mount horn to baseplate bracket and insert 3/8-16 x 1 1/4 hex head bolt, 3/8" lock washer and 1/4 x 1 x 1 nut plate. Clamp securely with vice grips. Mirror horn for passenger's side with driver's side and clamp securely. Drill hole in passenger side horn uniform with driver's side using 13/32" drill bit. Insert 3/8-16 x 1 1/4 hex head bolt, 3/8" lock washer and 1/4 x 1 x 1 nut plate.

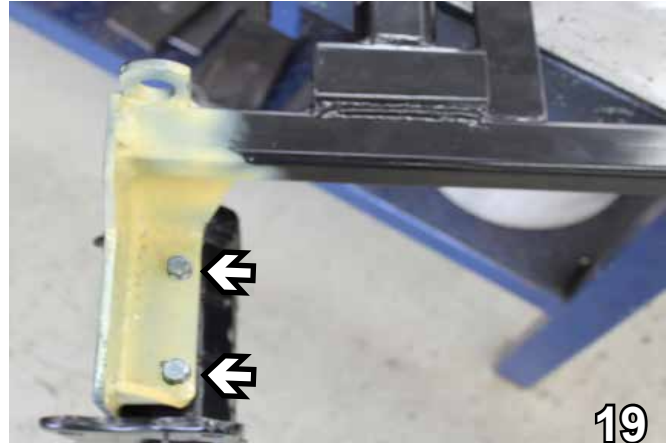

19. Turn baseplate upside down on your work surface. Using baseplate as a template, with a 13/32" drill bit, drill 2 holes on each side of the baseplate and insert 3/8-16 x 1 1/4 hex head bolt, 3/8" lock washer and 1/4 x 1 x 1 nut plate. Do this on both sides.

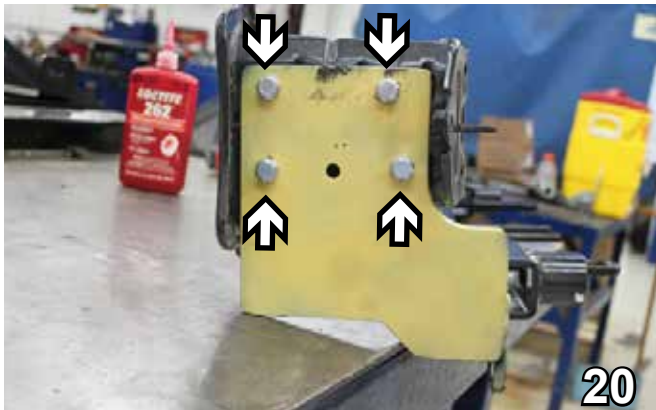

20. Turn baseplate back to an upright position. Using a 13/32" drill bit, drill remaining holes on each side of the baseplate and insert 3/8-16 x 1 1/4 hex head bolt, 3/8" lock washer and 1/4 x 1 x 1 nut plate (working from front to back).

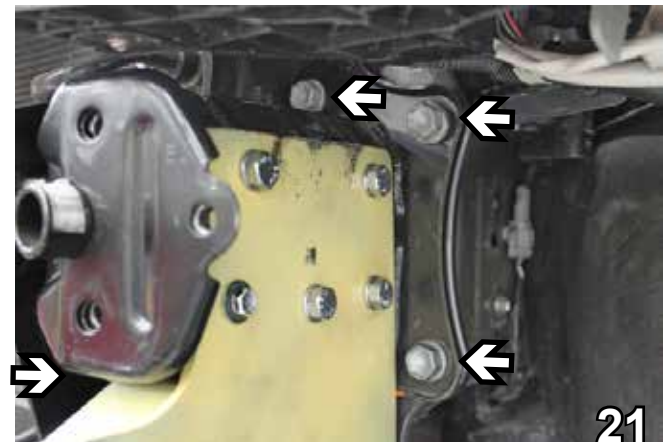

21. Mount baseplate onto vehicle, aligning with existing 4 holes for the horns (not pictured: 4th bolt hole on opposite side). Install existing bolts and tighten. Use Loctite Red on all bolts.

When using power drills be aware of the dangers of torque and drill bit length.

BE SURE TO USE LOCTITE® RED ON ALL BOLTS BEFORE TIGHTENING. TIGHTEN ALL BOLTS ACCORDING TO THE TORQUE CHART ON THE FRONT PAGE OF THESE INSTRUCTIONS OR ON PAGE 3 OF THE BASEPLATE TOWING GENERAL INSTRUCTIONS.



22. Before reinstallation of air baffle, hold air baffle as close to original position as possible. Mark and trim as necessary on air baffle to accommodate baseplate installation. Reinstall air baffle using existing bolts and tighten. Do this on both sides.

BX2911
2008 Lexus IS250
Installation Instructions



23. Reinstall the washer reservoir. Use the provided 6MM-1.0 x 30MM hex bolt and 1/4" flat washer for bolts in pictures 23A and 23B. Use existing bolt for picture shown in 23C (on top of fascia just inside of the headlight). Reattach fluid lines and electrical.



24. Wrap the permanent baseplate safety cables around the torsion bar twice and then attach to the provided convenience link on the baseplate. The photo to the left shows the recommended installation. Additional options may interfere with the suggested mounting; in this case, secure the cables to a solid piece of the frame as described in the instructions included with the permanent baseplate safety cables. Be sure the safety cables do not rub against any hoses or moving parts. Do this to both sides of the vehicle.

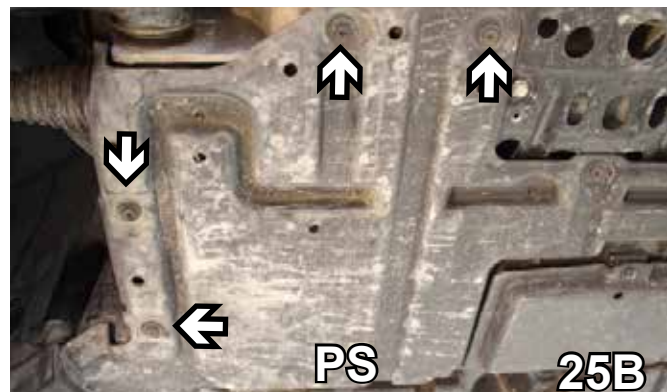
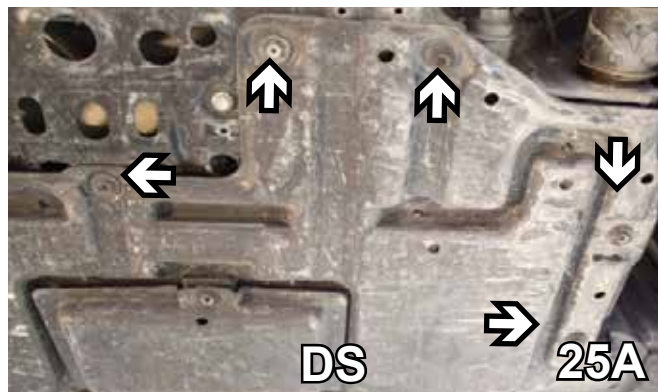

25. Reinstall splash guard using existing bolts.

BX2911

2008 Lexus IS250

Installation Instructions



26. Reinstall metal bumper. Remount the temperature sensor bracket and reattach sensor to the bracket. Use existing bolts.



27. Reinstall plastic belly pan under metal bumper, under baseplate. In order to accommodate attachment tabs, trim belly pan tabs parallel with the ground as marked in the above photo. Do this on both sides. (NOTE: Fascia will hold the belly pan in place when it is reinstalled.)

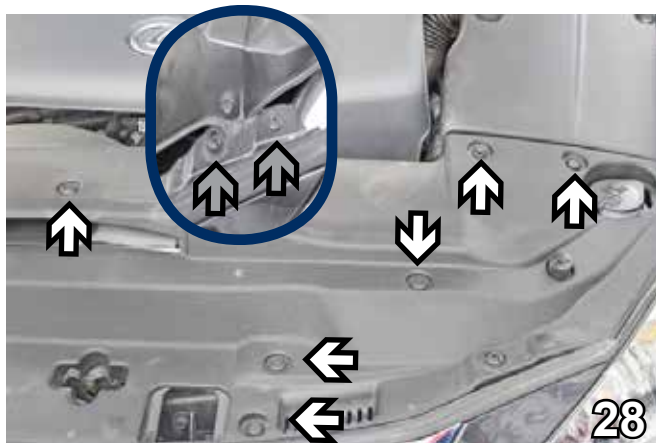

28. Prior to reinstalling plastic engine cover, inside of headlight, reinstall Phillips screw and pushpin (call out-gray arrows). Align engine cover and reinstall using existing 8 bolts.



29. **Optional:** Mount the breakaway bracket to the bottom of the metal bumper, all the way back to the bottom ridge of the bumper. Position it half-way between the electrical rods and the convenience link. Install using 1/4-20 x 3/4 hex bolt, 1/4-20 hex nyl nut, and #10-16 x 1" self-drilling screw.



30. Reinstall foglights and connect sensor back onto fascia. Align the fascia to its original position and trim the opening for the attachment tabs with diagonal cutters (gray arrows). Do this on both sides of the vehicle. **Optional:** Attach the electrical bracket to the center of the fascia (white arrow). - Photo at left.

BX2911

2008 Lexus IS250

Installation Instructions

Install the tow bar and safety cables according to the instructions provided in their packages. When demonstrating this to the customer, be sure to include all the contents and packages.

Do **NOT** substitute other devices if the tow bar pins and clips are misplaced.

DEALER or INSTALLER:
Be certain the user receives the instruction sheets for their products.



Shown without removable tabs installed.



Shown with removable tabs installed.

If the baseplate is in an accident, it must be replaced. DO NOT use it again! An accident can cause unseen damage and using it again could result in more damage or serious injury. DO NOT use the baseplate if it is damaged or missing parts.

CUSTOMER SERVICE COMMITMENT

Blue Ox is committed to providing you with exceptional customer care throughout your lifetime with our products. Our team is here to assist you with any questions you may have regarding the performance of your product. Simply call (402) 385-3051 and you can speak with our customer care team.

Additionally, please visit our website to see which rallies our Destination America team will be attending. For a nominal fee, our service technician will service your towing system to ensure it's in proper working condition. Also, as a commitment to our customers, should you visit our factory, you can stay at our full service Blue Ox campground at no charge along with enjoying a factory tour.

Again, thank you for being our customer and for the confidence you have shown in the performance of our products. It is because of customers like you we enjoy the success we have today.



© 2011 Blue Ox
One Mill Road, Industrial Park
Pender, Nebraska 68047
Phone: (402) 385-3051 • Fax: (402) 385-3360
www.blueox.com

General Information

1. Ensure that your product(s) are registered online at www.blueox.com. It is crucial to register your product(s) so that you may be alerted of product offerings, updates, upgrades, maintenance and safety bulletins, and/or recalls.
2. **It is the owner's responsibility to inspect all towing equipment for cracked welds, missing or worn parts and loose bolts before each towing trip.** Be sure to use Loctite® Red on all bolts and tighten to the recommended specifications.
3. **It is the owner's responsibility to hook up all towing equipment per manufacturer's instructions/recommendations.**
4. Remove the attachment tabs when not in use (if applicable).

Notice To Baseplate Installer

1. It is YOUR responsibility to watch for:

- Oil cooler and air conditioner lines
- Electrical wires and hoses
- Missing parts or attaching points on the frame

** If the baseplate is improperly installed and is against a wire or hose, it could cause fluid leaks or electrical shorts some time after the actual baseplate installation.

Permanent Baseplate Safety Cable Installation

Permanent baseplate safety cables are strongly recommended when towing a vehicle with a tow bar. The principle function of the permanent baseplate safety cables is to prevent the towed vehicle from breaking loose in the event the connection between the frame of the towed vehicle and the baseplate fails or becomes disconnected. The cables must be connected from the baseplate to the frame rail or cross member of the vehicle's frame. The illustrations below show the possible arrangements recommended by Blue Ox®. Each permanent baseplate safety cable must have an adequate weight rating for the towing system. The weight rating of the two (2) cables together will not qualify.

Do not mount the permanent baseplate safety cables against wires, hoses or brake lines.

These permanent baseplate safety cables should remain installed as long as the baseplate is installed on the vehicle. Permanent baseplate safety cables are to be used in conjunction with, and NOT a replacement for legally required safety cables attaching the towed vehicle to the towing vehicle.

OPTION #1

Permanent Baseplate Safety Cables to Cross Member or Frame of Towed Vehicle.

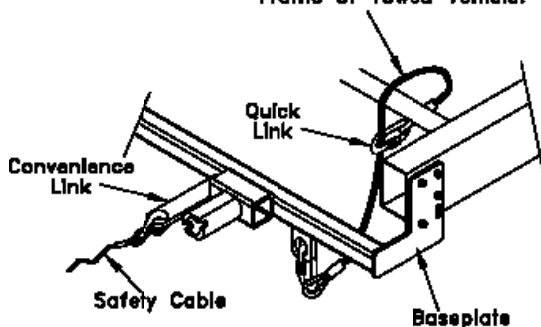

OPTION #2

Permanent Baseplate Safety Cables to Cross Member or Frame of Towed Vehicle.

