



**BX2905 Installation Instructions
2003-'05 Landrover Range Rover**

Serial No.

Strong As An Ox™ The upper grill and front fascia are removed for baseplate installation. Drilling is required. Minor trimming of air dam is required. The BX8869 is available for the vehicle. Attachment Tabs are 23 1/2 inches center to center and a height of 20 inches.



- 1. 2003-'04 Models:** Remove the three metric bolts from top side of upper grill using the 10MM socket. **2005 Model:** Requires a 7MM socket. Pull grill forward and up, disconnect temperature sensor and set grill aside.



- 3. Just forward of front tires, in wheel well, is one metric bolt to remove using either the phillips screw driver or a 7MM socket, both sides.**



- 5. Pull front tow hook cover down and forward, set aside. Remove two metric bolts in tow hook closure using the 10MM socket.**

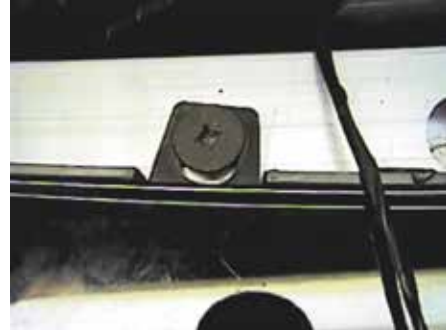

- 2. 2003-'04 Models:** Remove the three phillips head screws from the top side of metal bumper with the phillips screw driver. **2005 Model:** Will have four phillips screws to remove.



- 4. Remove two phillips head screws in opening just below metal bumper with the phillips screw driver, both sides.**



- 6. 2003-'04 Models:** Remove four metric bolts on the bottom side of the fascia, pull forward, disconnect running lights and set fascia aside. **2005 Model:** Will have four temperature sensors to disconnect from fascia.



Strong As An Ox™



7. Remove the four metric nuts from cross tube, just below metal bumper, with the 16MM socket and two metric bolts from the center braces with the 10MM socket, set tubing aside. **Tubing will not be reinstalled.** Also remove the two metric nuts just above the metric nuts on cross tube seen in the photo, both sides. Some **2005 Models** may not have this cross tube to remove.

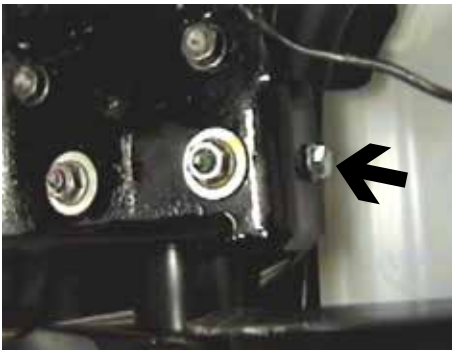

8. Place three 1/2" flat washers (item 6) on each lower stud, according to the drawing on page three.
9. **2003-'04 Models:** Hold baseplate into position to align with studs and trim air dam as needed. Set baseplate on to studs and tighten existing metric nuts. Note that the existing metric nut with the large washer is on the bottom studs, see drawing on page three. **2005 Models:** Will need to use the 10MM hex nuts and lock washers provided. **Be sure and use loctite on all bolts before tightening.** Using the baseplate as a template, drill the remaining hole with the 13/32" drill bit, both sides. Insert item 2 behind frame to align with drilled hole and tighten items 4 and 5 on baseplate sides. **Be sure and use loctite on all bolts before tightening.**

10. Reinstall front fascia, tow hook closure, upper grill and temperature sensor. Be sure all electrical connections are plugged in properly.

11. The dimensional variations between otherwise identical cars can be considerable. While the location and size of the holes in the baseplate were designed to allow for easy installation, it may be necessary to file a hole slightly to allow a bolt to clear.

12. Install the tow bar and safety cables according to the instructions included in their packages.

13. Do **not** substitute other devices if the tow bar pin and clip are lost.

14. **DEALER OR INSTALLER: BE CERTAIN THE USER RECEIVES THE INSTRUCTION SHEET.**

IMPORTANT: Use only genuine factory replacement parts on your Base Plate. Do not substitute homemade or nontypical parts. If a bolt is lost or in need of replacement, for your safety and the preservation of your Base Plate, be sure to use a replacement bolt of the same grade (Usually Grade 5, refer to parts list). Repair parts may be ordered through your nearest **Blue Ox** dealer or distributor.



Strong As An Ox™

Tools Required

7MM Socket
10MM Socket
Utility Knife

Loctite
16MM Socket

13/32" Drill Bit
Phillips Screw Driver

Parts List

Ref. No.	Qty.	Part No.	Description
1	1	61-5797	Weldment, Base Plate, BX2905
2	2	61-5208	3/8-16 Nut Plate
3	2	201-0443	3/8-16 x 1 Bolt, Grd. 5, ZP
4	2	201-0368	3/8-16 x 1 1/4 Bolt, Grd. 5, ZP
5	4	203-0010	3/8 Lock Washer, ZP
6	12	203-0005	1/2 Flat Washer, ZP
7	8	202-0111	10MM-1.50 Hex Nut, ZP
8	8	203-0104	10MM Lock Washer, ZP
9	8	203-0003	3/8 Flat Washer, ZP
10	2	201-0979	#12-14 x 1" Self Drilling Screw, ZP
11	2	201-0192	#10-32 x 1/2 Slot, Rd. Hd. Screw
12	2	203-0054	#10 Lock Washer
13	2	202-0047	#10-32 Hex Nut
14	2	101-5822	Adapter, 4 Way Connector
15	2	62-3469	Attachment, Assembly, Long (R)
	2	226-0046	Baseplate Safety Cable, 36" CL III (Not Shown)
	4	229-0359	Quicklink, 3/8, ZP (Not Shown)
	2	290-0437	Cap Plugs, Black (Not Shown)



Location of BX8869 on driver's side. Be aware of dividing wall on lower cavity.

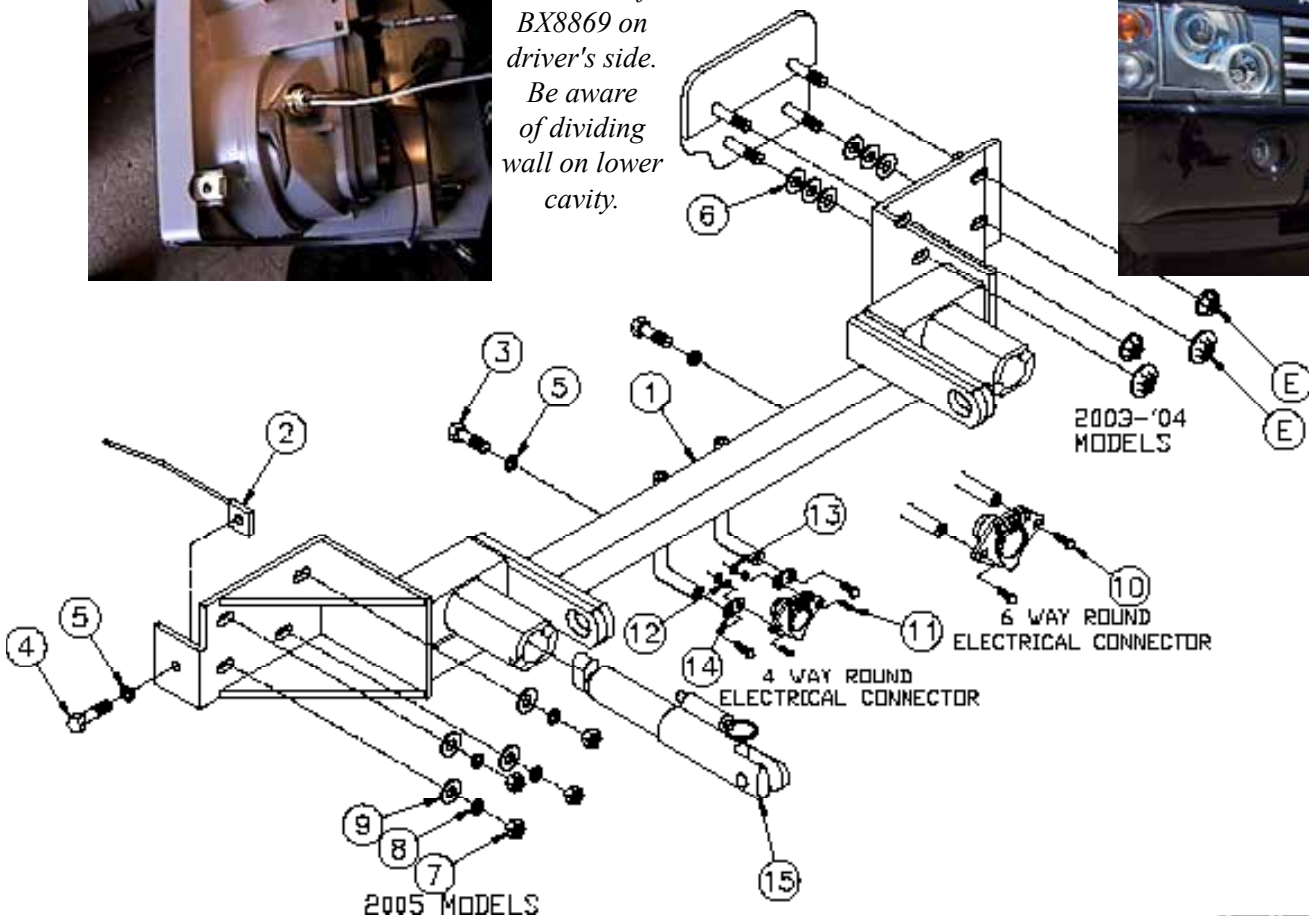

General Information

1. Ensure that your product(s) are registered online at www.blueox.com. It is crucial to register your product(s) so that you may be alerted of product offerings, updates, upgrades, maintenance and safety bulletins, and/or recalls.
2. **It is the owner's responsibility to inspect all towing equipment for cracked welds, missing or worn parts and loose bolts before each towing trip.** Be sure to use Loctite® Red on all bolts and tighten to the recommended specifications.
3. **It is the owner's responsibility to hook up all towing equipment per manufacturer's instructions/recommendations.**
4. Remove the attachment tabs when not in use (if applicable).

Notice To Baseplate Installer

1. It is YOUR responsibility to watch for:

- Oil cooler and air conditioner lines
- Electrical wires and hoses
- Missing parts or attaching points on the frame

** If the baseplate is improperly installed and is against a wire or hose, it could cause fluid leaks or electrical shorts some time after the actual baseplate installation.

Permanent Baseplate Safety Cable Installation

Permanent baseplate safety cables are strongly recommended when towing a vehicle with a tow bar. The principle function of the permanent baseplate safety cables is to prevent the towed vehicle from breaking loose in the event the connection between the frame of the towed vehicle and the baseplate fails or becomes disconnected. The cables must be connected from the baseplate to the frame rail or cross member of the vehicle's frame. The illustrations below show the possible arrangements recommended by Blue Ox®. Each permanent baseplate safety cable must have an adequate weight rating for the towing system. The weight rating of the two (2) cables together will not qualify.

Do not mount the permanent baseplate safety cables against wires, hoses or brake lines.

These permanent baseplate safety cables should remain installed as long as the baseplate is installed on the vehicle. Permanent baseplate safety cables are to be used in conjunction with, and NOT a replacement for legally required safety cables attaching the towed vehicle to the towing vehicle.

OPTION #1

Permanent Baseplate Safety Cables to Cross Member or Frame of Towed Vehicle.

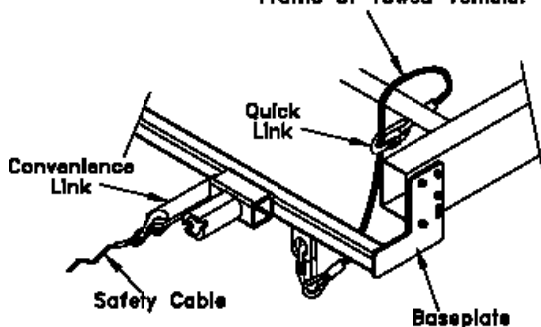

OPTION #2

Permanent Baseplate Safety Cables to Cross Member or Frame of Towed Vehicle.

