



Baseplate Installation Instructions

BX2721 2010-11 Kia Optima LX (No Foglights) Installation Instructions

Serial Number

Please read BOTH these Installation Instructions and the General Instructions before attempting to install or operate this equipment.

- Blue Ox® towing products and accessories are intended to be installed by Blue Ox® Dealers who are familiar with our products and have the equipment and knowledge to do “fit work”. When necessary Blue Ox® Dealers can be found at www.blueox.com or by contacting our Customer Care Department at (402) 385-3051.
- Many Blue Ox® baseplates are designed to use existing holes and hardware to mount the baseplate to the towed vehicle. Even though bolts are there, do not assume they are adequate for baseplate mounting. Always use hardware supplied in the hardware kit or existing hardware specified in the Baseplate Towing Installation Instructions.

Attachment Tab Height: 13”

Attachment Tab Width: 20”

Bolt Torque Specifications
Torque in Foot-Pounds for Metric Bolts

Bolt Size	Grade 8.8	Grade 10.9
6MM	6	8
8MM	16	22
10MM	31	40
12MM	54	70
14MM	89	117

Confirm the towability and pre-towing procedures for your vehicle with the owner’s manual or contact the vehicle’s manufacturer for specific towing procedures.

Bolt Torque Specifications
Torque in Foot-Pounds for Inch Bolts

Bolt Size	Grade 5	Grade 8
1/4”	10	14
5/16”	19	29
3/8”	33	47
7/16”	54	78
1/2”	78	119
5/8”	154	230



WARNING
Failure to read and follow these instructions could result in separation of the towed vehicle from the tow bar, causing property damage, loss of towed vehicle, personal injury or death.

If the front of your vehicle looks different than this, call us at (402) 385-3051.

BX2721

2010-11 Kia Optima LX

(No Foglights)

Installation Instructions

Parts List			
Ref. No.	Qty.	Part No.	Description
1	1	61-6868	WLDM'T, BP, BX2721
2	6	61-5208	WLD, NUT PLT, 1/4X1X1, 3/8"/14"WIRE
3	10	201-0368	3/8-16 X 1 1/4 HEX HEAD BOLT,GRD. 5
4	1		EXISTING METRIC BOLT
5	10	203-0010	3/8" LOCK WASHER, ZP
6	4	202-0090	3/8-16 HEX NYL. INS. LOCK NUT, ZP
7	2	201-0979	#12-14 X 1" SELF DRILLING SCREW, ZP
8	2	201-0192	10-32 X 1/2 SLOT, RD. HD. SCREW
9	2	203-0054	#10 LOCK WASHER
10	2	202-0047	10-32 X 1/2 SLOT, RD. HD. SCREW
11	2	101-5822	ADAPTER, 4 WAY CONNECTOR
12	2	62-3469	ATT TAB ASSY, REM, SF/LB, 1 HOLE
13	1	102-7056	COOLANT BRKT, BX1689
14	1	201-0367	1/4-20 X 1 3/4 HEX HEAD BOLT GRD. 5
15	1	201-0050	14-20 X 3/4 HEX BOLT GRD.5, ZP
16	2	202-0102	1/4-20 HEX NYL NUT, ZP
	2	226-0046	BASEPLATE SAFETY CABLE, 36" CL III (Not Shown)
	2	229-0359	QUICKLINK, 3/8, ZP (Not Shown)
	2	290-0437	RECEIVER, CAP PLUG (BLK) (Not Shown)
	1	201-0461	6MM-1.0 X 16MM,HEX BLT, GRD 8.8,ZP (Not Shown)
	1	203-0008	1/4 LOCK WASHER, ZP (Not Shown)
	1	203-0001	1/4 FLAT WASHER, ZP (Not Shown)

Tools Required

- | | |
|-------------------|-----------------------|
| 8MM Socket | Phillips Screw Driver |
| 10MM Socket | Torque Wrench |
| 12MM Socket | Tape Measure |
| 9/16" Socket | Drill |
| Large Vise Grip | Pliers |
| Flat Screw Driver | 13/32" Drill Bits |
| Loctite® RED | |

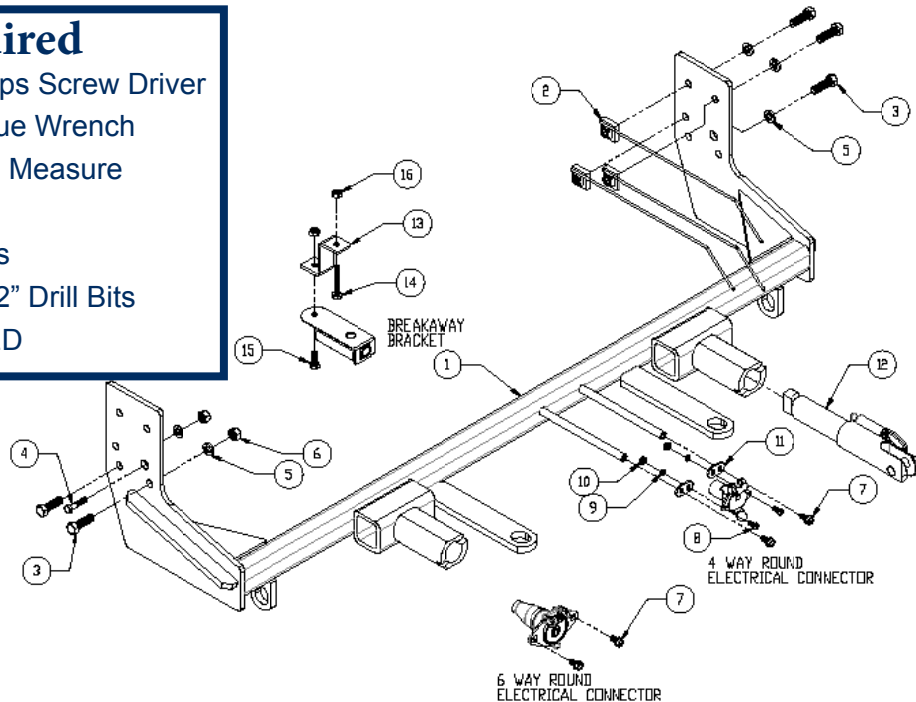

Important:

Use only genuine factory replacement parts on your baseplate. Do **NOT** substitute homemade or non-typical parts. If a bolt is lost or in need of replacement, for your safety and the preservation of your baseplate, be sure to use a replacement bolt of the same grade (In most cases it will be Grade 5, please reference the parts list above). Replacement parts may be ordered through your nearest Blue Ox® Dealer or Distributor. Failing to follow and/or altering these installation instructions in either installation or required equipment will void the manufacturer's warranty.

BX2721
2010-11 Kia Optima LX
(No Foglights)
Installation Instructions

Attachment Tabs:

Due to the design of the removable tabs, the RangeFinder II, Acclaim and Ambassador tow bars can not be used. Adapters, except the BX8833 and BX88151, can not be used with this baseplate.

Instructions:

The fascia, bumper and washer reservoir are removed for the baseplate installation. Drilling is required. Trimming of the frame, bumper and air dam is required.

The dimensional variations between otherwise identical vehicles can be considerable. While the baseplate was designed for easy installation, it may be necessary to tailor the baseplate slightly to compensate for auto manufacturer's tolerances. These minor adjustments may include filing a hole slightly, bending electrical rods or bending end plates.

The BX8869 Bulb and Socket Wiring Kit is available for this vehicle.



Installation Instructions:



1. Using a flat screw driver, remove four push pins from the top of the fascia (white arrows). Using a 10MM socket, also remove two metric bolts from the top of the fascia. Set aside to be reinstalled later. Do this on both sides.



2. Using a pliers, straighten the clip and unhook the top piece of fascia and remove. Do this on both sides. Set aside it will be reinstalled later.

Handling of some cosmetic parts when installing this product may require the use of protective covers, rags, specialty tools, etc. to prevent damage.

BX2721
2010-11 Kia Optima LX
(No Foglights)
Installation Instructions



3. Just forward of the front tire, on the edge of the wheel well remove the bolt with an 8MM socket or a Phillips screw driver. Do this on both sides and set aside to reinstall later.



4. Just forward of the front tire on the lower edge of the fascia are three push pins to remove. Do this on both sides and set aside to be reinstalled later.



5. Continuing around the lower edge of the fascia, remove two more push pins. Do this on both sides and set aside to be reinstalled later.



6. In the middle on the lower edge of the fascia, using a 10MM socket remove the bolt. Set aside to be reinstalled later.



7. Lift and pull fascia's corner out to the side to release the clips, pull fascia forward both sides, unplug all electrical components if necessary and set fascia aside carefully.

BX2721
2010-11 Kia Optima LX
(No Foglights)
Installation Instructions



8. Using a 12MM socket, remove the two bolts above the bumper (white arrows). Use a 10MM socket to remove the middle bolt (gray arrow). Do this on both sides of the vehicle. Set the bolts aside to be reinstalled later



9. Using a 12MM socket, remove the inside bolt below the bumper (white arrow). Using a 10MM socket, remove the outside bolt (gray arrow). Do this to both sides of the vehicle. Set the bolts aside to reinstall later.

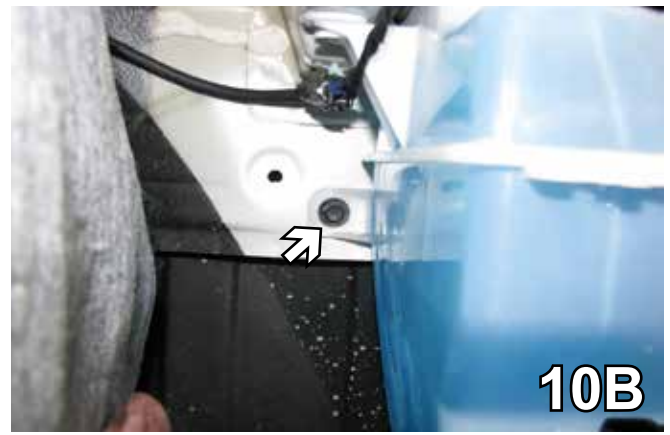

10. On the passenger side, unplug the electrical lines and the hoses from the washer reservoir and cap. Using a 10MM socket, remove one bolt on each side. Pull the washer reservoir off and set aside to be reinstalled later.

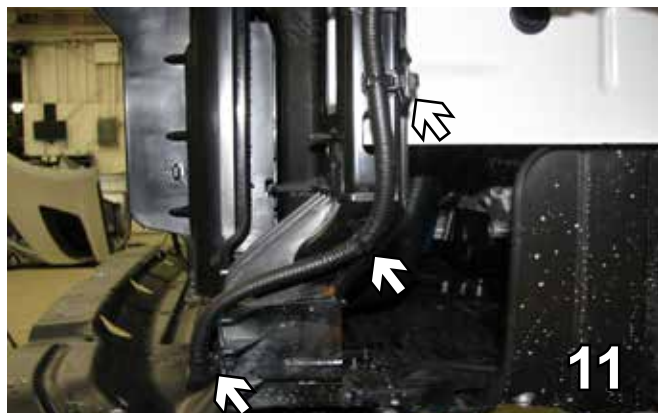

11. On the driver's side, unplug the hoses and move out of the way.

BX2721
2010-11 Kia Optima LX
(No Foglights)
Installation Instructions

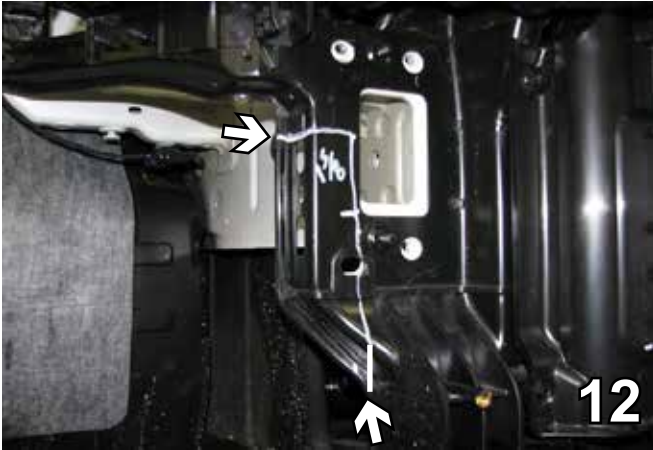

12. Using a reciprocating saw cut straight across under the ridge and flush to the frame, about 1 5/8", and straight down. Do this on both sides.



13. Temporarily put the bumper back on to mark on the back side the area to be trimmed. Remove this area with the reciprocating saw, both sides.



14. Trim on the inner edge of the air dam, under the grommet and cut straight down the crease. Remove this area with the reciprocating saw, both sides.

Baseplate painted yellow for illustration.
Actual baseplate will be powder-coat black.



15. Slide the baseplate on to the frame rail to align with the existing hole for the washer reservoir on the passenger's side (gray arrow). Be sure the baseplate is level with respect to the vehicle frame. Clamp the baseplate to the frame rail with the vise grip. Using the baseplate as a template, drill the top inside hole with the 13/32" drill bit (white arrow).

When using power drills be aware of the dangers of torque and drill bit length.

BX2721
2010-11 Kia Optima LX
(No Foglights)
Installation Instructions



16 Align the baseplate the same way on the driver side, Be sure the baseplate is level with respect to the vehicle frame. Clamp the baseplate to the frame rail with the vise grip. Using the baseplate as a template, drill the top inside hole with the 13/32" drill bit (white arrow). Then drill the remaining four holes on each side.

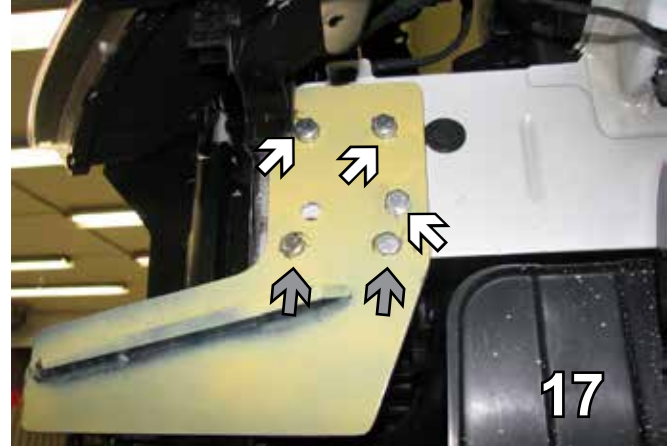

17. Insert the nut plates into the end of frame rail, just behind metal bumper bracket to align with the top three drilled holes, insert 3/8-16 x 1 1/4" hex bolts and 3/8" lock washers into baseplate drilled holes with the 9/16" socket (white arrows). Insert 3/8-16 x 1 1/4" hex bolts and 3/8" lock washers into baseplate bottom two holes to align with 3/8-16 lock nuts tighten with the 9/16" socket (gray arrows), both sides. Be sure to use Loctite on all bolts.

BE SURE TO USE LOCTITE® RED ON ALL BOLTS BEFORE TIGHTENING. TIGHTEN ALL BOLTS ACCORDING TO THE TORQUE CHART ON THE FRONT PAGE OF THESE INSTRUCTIONS OR ON PAGE 3 OF THE BASEPLATE GENERAL TOWING INSTRUCTIONS.

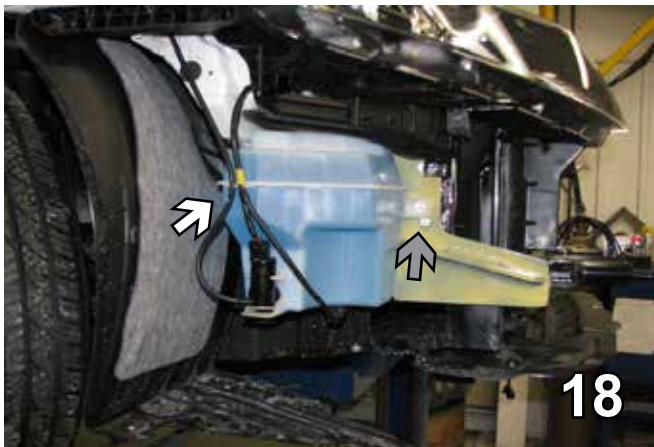

18. Reinstall the washer reservoir on the passenger side, using the existing bolt on the inside hole (white arrow). In the outside hole, insert a 6MM-1 x 15MM hex bolt with a 1/4" flat and lock washers (gray arrow). Be sure that all the electrical connections and hoses are plugged in properly.



19. Attach the permanent baseplate safety cables to the provided convenience link on the baseplate (see grey arrow). The photo above shows the recommended installation of the cables to frame of vehicle (see white arrow). Additional options may interfere with suggested mounting; in this case secure the cables to a solid piece of the frame as described in the instructions included with the permanent baseplate safety cables. Be sure the safety cables do not rub against any hoses or moving parts. Do this to both sides of the vehicle.

BX2721
2010-11 Kia Optima LX
(No Foglights)
Installation Instructions



20. Reinstall the bumper. Drill through the existing hole on the underside of the bumper. Position the bracket and insert a 1/4-20 x 1 3/4" hex bolt with a 1/4-20 hex nut and tighten.



21. Attach the breakaway to the bracket with a 1/4-20 x 3/4" hex bolt and 1/4-20 hex nut. The fascia will need to be trimmed to allow the breakaway to come through the fascia. Reinstall fascia. **Be sure all electrical components are plugged in properly.**



22. *Location for the 4 or 6 pin electrical coupler on the fascia's lower air dam just below license plate.*

Be sure that ALL electrical connections are plugged in properly and functioning BEFORE Installing the fascia.

23. The dimensional variations between otherwise identical cars can be considerable. While the baseplate was designed for easy installation, it may be necessary to tailor the baseplate slightly to compensate for auto manufacturers' tolerances. These minor adjustments may include filing a hole slightly, bending electrical rods, adding and/or bending endplates.

24. Install the tow bar and safety cables according to the instructions included in their packages.

25. Do **not** substitute other devices if the tow bar pin and clip are lost.

26. **DEALER OR INSTALLER: BE CERTAIN THE USER RECEIVES THE INSTRUCTION SHEET.**

BX2721
2010-11 Kia Optima LX
(No Foglights)
Installation Instructions

DEALER or INSTALLER:

Be certain the user receives the instruction sheets for their products.



Shown without Removable Tabs Installed.



Shown with Removable Tabs Installed.

If the baseplate is in an accident, it must be replaced. DO NOT use it again! An accident can cause unseen damage and using it again could result in more damage or serious injury. DO NOT use the baseplate if it is damaged or missing parts.

CUSTOMER SERVICE COMMITMENT

Blue Ox is committed to providing you with exceptional customer care throughout your lifetime with our products. Our team is here to assist you with any questions you may have regarding the performance of your product. Simply call (402) 385-3051 and you can speak with our customer care team.

Additionally, please visit our website to see which rallies our Destination America team will be attending. For a nominal fee, our service technician will service your towing system to ensure it's in proper working condition. Also, as a commitment to our customers, should you visit our factory you can stay at our full service Blue Ox campground at no charge along with enjoying a factory tour.

Again, thank you for being our customer and for the confidence you have shown in the performance of our products. It is because of customers like you we enjoy the success we have today.



© 2011 Blue Ox
One Mill Road, Industrial Park
Pender, Nebraska 68047
Phone: (402) 385-3051
Fax: (402) 385-3360
www.blueox.com
6/1/11

General Information

1. Ensure that your product(s) are registered online at www.blueox.com. It is crucial to register your product(s) so that you may be alerted of product offerings, updates, upgrades, maintenance and safety bulletins, and/or recalls.
2. **It is the owner's responsibility to inspect all towing equipment for cracked welds, missing or worn parts and loose bolts before each towing trip.** Be sure to use Loctite® Red on all bolts and tighten to the recommended specifications.
3. **It is the owner's responsibility to hook up all towing equipment per manufacturer's instructions/recommendations.**
4. Remove the attachment tabs when not in use (if applicable).

Notice To Baseplate Installer

1. **It is YOUR responsibility to watch for:**

- Oil cooler and air conditioner lines
- Electrical wires and hoses
- Missing parts or attaching points on the frame

** If the baseplate is improperly installed and is against a wire or hose, it could cause fluid leaks or electrical shorts some time after the actual baseplate installation.

Permanent Baseplate Safety Cable Installation

Permanent baseplate safety cables are strongly recommended when towing a vehicle with a tow bar. The principle function of the permanent baseplate safety cables is to prevent the towed vehicle from breaking loose in the event the connection between the frame of the towed vehicle and the baseplate fails or becomes disconnected. The cables must be connected from the baseplate to the frame rail or cross member of the vehicle's frame. The illustrations below show the possible arrangements recommended by Blue Ox®. Each permanent baseplate safety cable must have an adequate weight rating for the towing system. The weight rating of the two (2) cables together will not qualify.

Do not mount the permanent baseplate safety cables against wires, hoses or brake lines.

These permanent baseplate safety cables should remain installed as long as the baseplate is installed on the vehicle. Permanent baseplate safety cables are to be used in conjunction with, and NOT a replacement for legally required safety cables attaching the towed vehicle to the towing vehicle.

OPTION #1

Permanent Baseplate Safety Cables to Cross Member or Frame of Towed Vehicle.

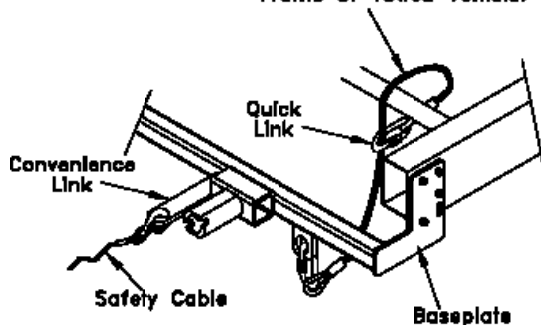

OPTION #2

Permanent Baseplate Safety Cables to Cross Member or Frame of Towed Vehicle.

