

Please read **BOTH** these Installation Instructions and the General Towing Instructions before attempting to install or operate this equipment.

- Blue Ox® towing products and accessories are intended to be installed by Blue Ox® Dealers who are familiar with our products and have the equipment and knowledge to do “fit work”. When necessary, Blue Ox® Dealers can be found at [www.blueox.us](http://www.blueox.us) or by contacting our Customer Care Department at (888) 425-5382
- Many Blue Ox® Baseplates are designed to use existing holes and hardware to mount the baseplate to the towed vehicle. Even though bolts are there, do not assume they are adequate for baseplate mounting. Always use hardware supplied in the hardware kit or existing hardware specified in the Baseplate Installation Instructions.

Attachment Tab Height: 11 1/2”  
Attachment Tab Width: 26”

### Bolt Torque Specifications

Torque in Foot-Pounds for Metric Bolts

Bolt Size	Grade 8.8	Grade 10.9
6MM	6	8
8MM	16	22
10MM	31	40
12MM	54	70
14MM	89	117

Confirm the towability and pre-towing procedures for your vehicle with the owner’s manual or contact the vehicle’s manufacturer for specific towing procedures.

### Bolt Torque Specifications

Torque in Foot-Pounds for Inch Bolts

Bolt Size	Grade 5	Grade 8
1/4”	10	14
5/16”	19	29
3/8”	33	47
7/16”	54	78
1/2”	78	119
5/8”	154	230



## **WARNING**

Failure to read and follow these instructions could result in separation of the towed vehicle from the tow bar, causing property damage, loss of towed vehicle, personal injury or death.

# BX2611

## 2008-09 Mercury Grand Marquis

### Installation Instructions

### Parts List

Ref. No.	Qty.	Part #	Description
1	1	61-6653	Weldment, Base Plate, BX2611
2	8	61-5208	3/8-16 Nut Plate, with 14" Wire
3	2	61-5342	Weldment, Nut Plate
4	8	201-0440	3/8-16 X 1 1/2 Hex Bolt, Grd.5, ZP
5	8	203-0010	3/8" Lock Washer, ZP
6	2	201-0051	1/2-13 X 1 1/2 Hex Bolt Grd.5, ZP
7	2	203-0012	1/2 Lock Washer, ZP
8	2	201-0979	#12-14 x 1" Self Drilling Screw, ZP
9	2	201-0192	10-32 X 1/2 Slot, RD. HD. Screw
10	2	203-0054	#10 Lock Washer
11	2	202-0047	#10-32 Hex Nut
12	2	101-5822	Adapter, 4 Way Connector
13	2	62-3469	Attachment Tab Assembly, Removable SF/LB, 1 Hole
	2	226-0049	Baseplate Safety Cable, 36" CL IV (Not Shown)
	2	229-0359	Quicklink, 3/8, ZP (Not Shown)
	2	290-0437	Cap Plug, Black (Not Shown)

### Tools Required

- 5.5MM Socket
- 7MM Socket
- 8MM Socket
- 10MM Socket
- 11MM Socket
- 9/16" Socket
- Large Vise Grips

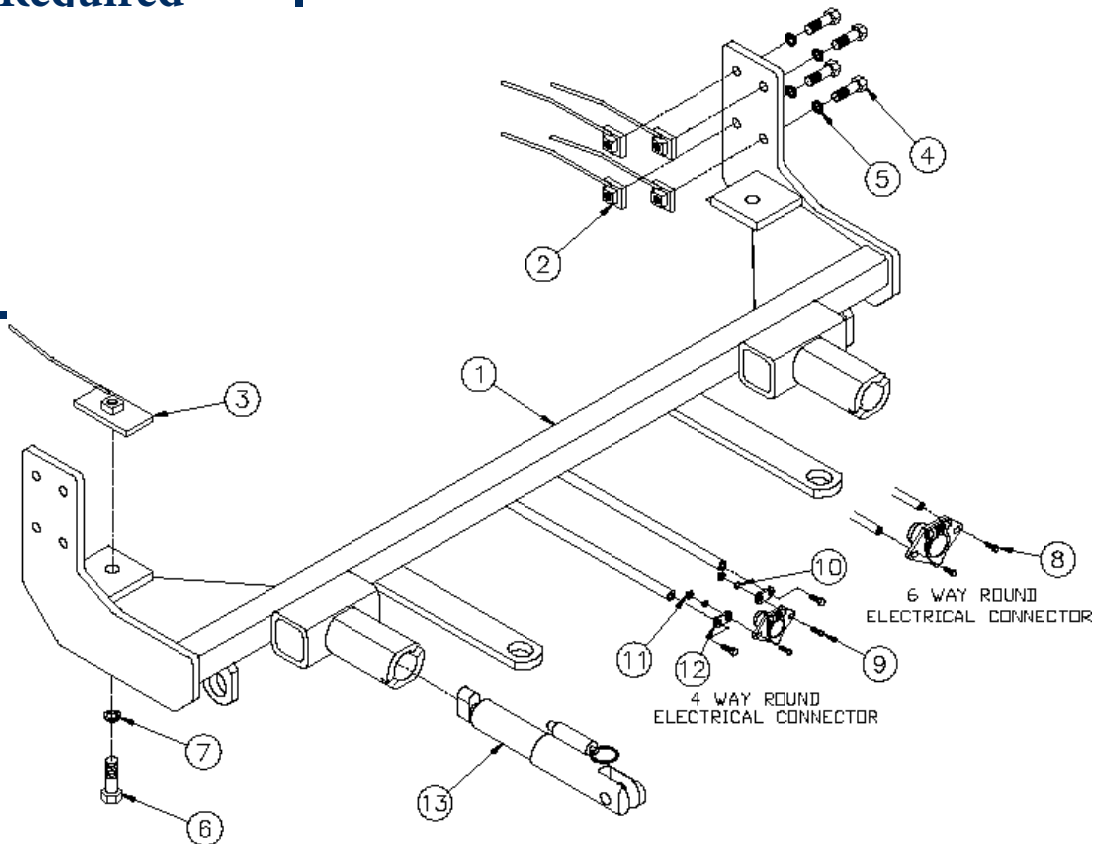

### Important:

Use only genuine factory replacement parts on your baseplate. Do **NOT** substitute homemade or non-typical parts. If a bolt is lost or in need of replacement, for your safety and the preservation of your baseplate, be sure to use a replacement bolt of the same grade (In most cases it will be Grade 5, please reference the parts list above). Replacement parts may be ordered through your nearest Blue Ox® Dealer or Distributor.

# BX2611

## 2008-09 Mercury Grand Marquis

### Installation Instructions

#### Attachment Tabs:

The weight of this vehicle is near the Class III, 5,000 lbs. rating limitations. Some models, depending on options, may well exceed this 5,000 lb rating. Be sure to confirm the weight of your individual vehicle before towing. As of 1999 the Aventa® II is now rated 10,000 lbs. and either the Aventa® II or the Aventa® LX tow bar must be used for these applications.

**Tow Bar Adapters are NOT to be used with vehicle's weighing over 5,000 lbs.**

**Installation Notes:** The grille, front fascia and blinker assemblies are removed and replaced during installation. Drilling is required. The air dam must be trimmed.

The dimensional variations between otherwise identical vehicles can be considerable. While the baseplate was designed for easy installation, it may be necessary to tailor the baseplate slightly to compensate for auto manufacturer's tolerances. These minor adjustments may include filing a hole slightly, bending electrical rods, and/ or bending end plates.

The BX8869 Bulb and Socket Wiring Kit is recommended for this vehicle.

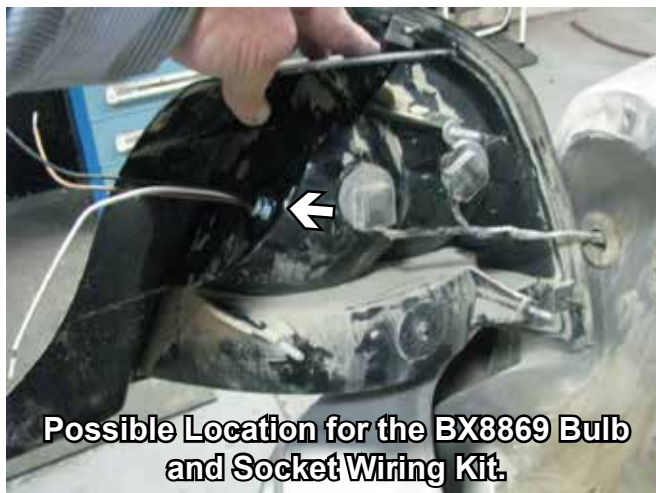

#### Installation Instructions:



1. Remove the three Christmas tree pins just forward of the front tire. Do this to both sides of the vehicle. Set the pins aside to reinstall later.



2. Unscrew three pins from the black plastic on the top edge of the fascia. Lift up and set plastic and pins aside to be reinstalled later.

BX2611  
2008-09 Mercury Grand Marquis  
Installation Instructions



3. Using the 11MM socket, remove three metric hex nuts from both blinker assemblies, located just behind the head light area. Pull to the side, unplug and set aside. Do this to both sides of the vehicle.

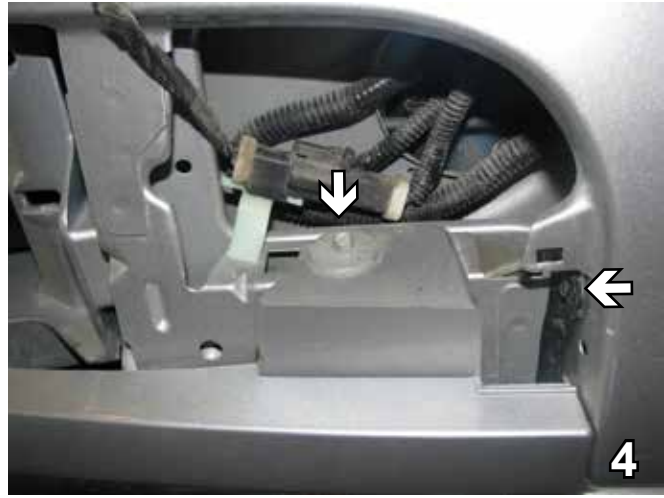

4. Using the 5MM and 8MM sockets, remove the two hex head screws from blinker opening. Do this to both sides of the vehicle. Set bolts aside to be reinstalled later.



5. Using a 10MM socket, remove the screw from the lower black panel located forward of front tires and below air dam. Do this to both sides of the vehicle. Set screws aside to be reinstalled later.



6. Using an 8MM socket, remove the eight screws with washers on the underside of the bumper fascia. Pull the fascia straight out to remove it. Do this to both sides of the vehicle. Set fascia and screws carefully aside to be reinstalled later.

BX2611  
2008-09 Mercury Grand Marquis  
Installation Instructions

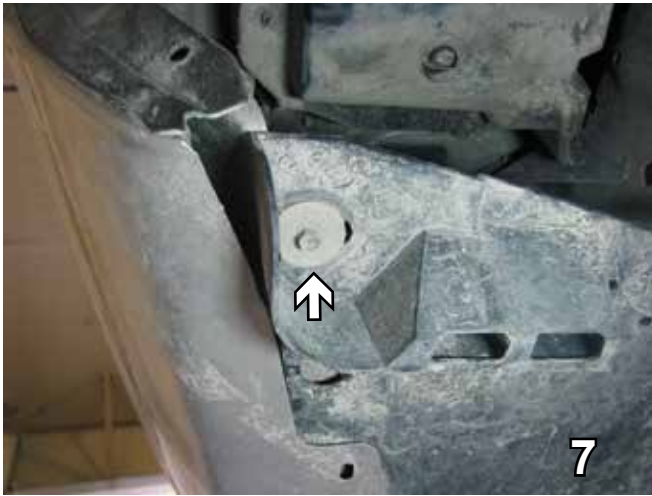

7. Using an 8MM socket, remove the metric screw from the lower side of the air dam. Do this to both sides of the vehicle. Set the screw aside to be reinstalled later.

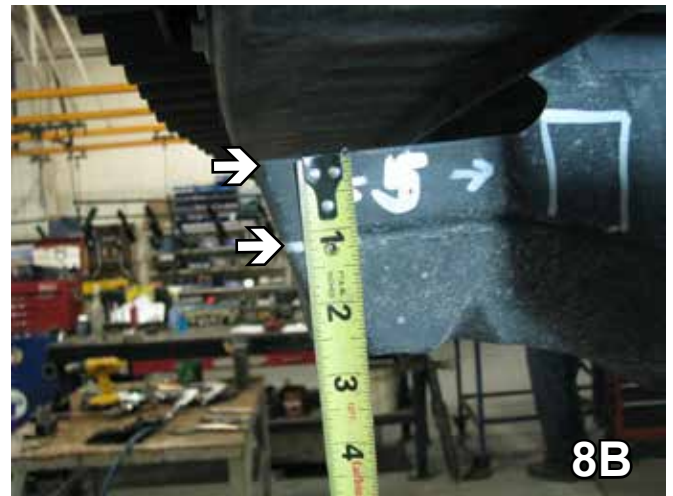

8. Trim the air dam 5" across and 1" down.



9. Using a 7MM socket, remove one metric screw on the air dam just behind the metal bumper. Do this to both sides.

BX2611  
2008-09 Mercury Grand Marquis  
Installation Instructions



10. Remove the Christmas tree push pin from the air dam. Do this to both sides. Set pin aside to reinstall later.



11. Slide the baseplate up on to the frame, then clamp the baseplate securely. Using the baseplate as a template, drill one 13/32" hole on each side. Install and tighten, one 3/8-16 x 1 1/2" hex bolt with a 3/8" lock washer and 14" wire nut plate inserted into the frame. Do this to both sides of the vehicle. Be sure to use loctite on all bolts before tightening.



12. Insert one 1/2-13 x 1 1/2" hex bolt with a 1/2" lock washer into the bottom hole and attach it to a 10" wire nut plate inserted into the frame. Do this to both sides of the vehicle. Be sure to use loctite on all bolts before tightening.

**BE SURE TO USE LOCTITE® RED ON ALL BOLTS BEFORE TIGHTENING. TIGHTEN ALL BOLTS ACCORDING TO THE TORQUE CHART ON THE FRONT PAGE OF THESE INSTRUCTIONS OR ON PAGE 3 OF THE BASEPLATE TOWING GENERAL INSTRUCTIONS.**

BX2611  
2008-09 Mercury Grand Marquis  
Installation Instructions



13. Using the baseplate as a template with the 13/32" drill bit, drill the three holes on the side.

Note: The bumper was removed for clarity. If desired remove the four (4) nuts from each side of the bumper and set aside. Reinstall after baseplate installation.

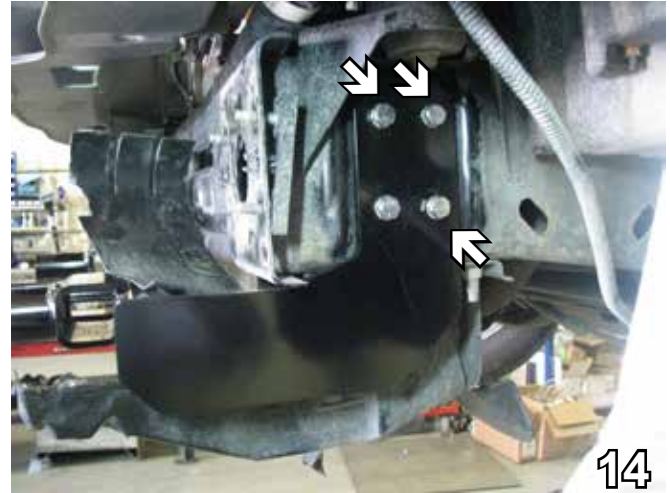

14. Install 3/8-16 x 1 1/2" hex bolts with 3/8" lock washers and 14" wire nut plates inserted into the frame. Do this to both sides of the vehicle. Be sure to use loctite on all the bolts.



15. Attach the permanent baseplate safety cables to the provided convenience link on the baseplate. The photo above shows the recommended installation of the permanent baseplate safety cables to frame of the vehicle. Additional options may interfere with suggested mounting, in this case secure the cables to a solid piece of the frame as described in the instructions included with the permanent baseplate safety cables. Be sure the safety cables do not rub against any hoses or moving parts.

16. Reattach the blinker assemblies and plug in. Replace the grille and fascia, reinstalling all the nuts, pins and screws.

Install the tow bar and safety cables according to the instructions provided in their packages. When demonstrating this to the customer, be sure to include all the contents and packages.

Do **NOT** substitute other devices if the tow bar pins and clips are misplaced.

Be sure that **ALL** electrical connections are plugged in properly and functioning **BEFORE** installing the fascia.

BX2611  
2008-09 Mercury Grand Marquis  
Installation Instructions

**DEALER or INSTALLER:**

**Be certain the user receives the instruction sheets for their products.**

**CUSTOMER SERVICE COMMITMENT**



Blue Ox is committed to providing you with exceptional customer care throughout your lifetime with our products. Our team is here to assist you with any questions you may have regarding the performance of your product. Simply call 1-800-228-9289 and you can speak with our customer care team.

Additionally, please visit our website to see which rallies our Destination America team will be attending. For a nominal fee, our service technician will service your towing system to ensure it's in proper working condition. Also as a commitment to our customers, should you visit our factory you can stay at our full service Blue Ox campground at no charge along with enjoying a factory tour.

Again thank you for being our customer and for the confidence you have shown in the performance of our products. It is because of customers like you we enjoy the success we have today.



© 2009 Blue Ox  
One Mill Road, Industrial Park  
Pender, Nebraska 68047  
Phone: (402) 385-3051 • Fax: (402) 385-3360  
[www.blueox.us](http://www.blueox.us)



# General Information

1. Ensure that your product(s) are registered online at [www.blueox.com](http://www.blueox.com). It is crucial to register your product(s) so that you may be alerted of product offerings, updates, upgrades, maintenance and safety bulletins, and/or recalls.
2. **It is the owner's responsibility to inspect all towing equipment for cracked welds, missing or worn parts and loose bolts before each towing trip.** Be sure to use Loctite® Red on all bolts and tighten to the recommended specifications.
3. **It is the owner's responsibility to hook up all towing equipment per manufacturer's instructions/recommendations.**
4. Remove the attachment tabs when not in use (if applicable).

## Notice To Baseplate Installer

### 1. It is YOUR responsibility to watch for:

- Oil cooler and air conditioner lines
- Electrical wires and hoses
- Missing parts or attaching points on the frame

\*\* If the baseplate is improperly installed and is against a wire or hose, it could cause fluid leaks or electrical shorts some time after the actual baseplate installation.

## Permanent Baseplate Safety Cable Installation

Permanent baseplate safety cables are strongly recommended when towing a vehicle with a tow bar. The principle function of the permanent baseplate safety cables is to prevent the towed vehicle from breaking loose in the event the connection between the frame of the towed vehicle and the baseplate fails or becomes disconnected. The cables must be connected from the baseplate to the frame rail or cross member of the vehicle's frame. The illustrations below show the possible arrangements recommended by Blue Ox®. Each permanent baseplate safety cable must have an adequate weight rating for the towing system. The weight rating of the two (2) cables together will not qualify.

***Do not mount the permanent baseplate safety cables against wires, hoses or brake lines.***

These permanent baseplate safety cables should remain installed as long as the baseplate is installed on the vehicle. Permanent baseplate safety cables are to be used in conjunction with, and NOT a replacement for legally required safety cables attaching the towed vehicle to the towing vehicle.

### OPTION #1

Permanent Baseplate Safety Cables to Cross Member or Frame of Towed Vehicle.

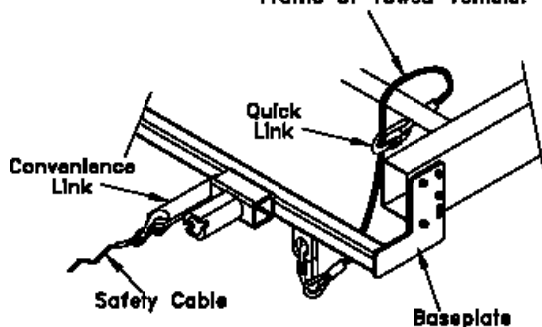

### OPTION #2

Permanent Baseplate Safety Cables to Cross Member or Frame of Towed Vehicle.

