



BX2408

2012-17 Dodge Journey (No GT) Installation Instructions

Attachment Tab Height: 14"

Attachment Tab Width: 22"

Serial Number

Please read BOTH these Installation Instructions and the General Information sheet prior to installing or operating this equipment.

- Blue Ox® towing products and accessories are intended to be installed by Blue Ox® Dealers who are familiar with our products and have the equipment and knowledge necessary to do "fit work". If needed, Blue Ox® Dealers can be found at www.blueox.com or by contacting our Technical Service Department at (402) 385-3051.
- Many Blue Ox® baseplates are designed to use existing holes and hardware to mount the baseplate to the towed vehicle. Even though bolts are there, do not assume they are adequate for baseplate mounting. Always use the hardware supplied in the hardware kit and existing hardware as specified in the installation instructions.

Bolt Torque Specifications

Torque in Foot-Pounds for Metric Bolts

Bolt Size	Grade 8.8	Grade 10.9
6MM	6	8
8MM	16	22
10MM	31	40
12MM	54	70
14MM	89	117

Bolt Torque Specifications

Torque in Foot-Pounds for Inch Bolts

Bolt Size	Grade 5	Grade 8
1/4"	10	14
5/16"	19	29
3/8"	33	47
7/16"	54	78
1/2"	78	119
5/8"	154	230



If the front of your vehicle looks different than this, please contact us at (402)385-3051.

Reference your vehicle owner's manual for manufacturer's towing specifications.



WARNING

Failure to read and follow these instructions could result in separation of the towed vehicle from the tow bar, causing property damage, loss of towed vehicle, personal injury or death.

BX2408
2012-17 Dodge Journey (No GT)
Installation Instructions

Instruction Notes: The fascia, metal bumper, battery and battery box are removed and reinstalled for the baseplate installation. Some drilling and trimming is required.

Place all components that are removed on a flat, sturdy surface. All items will be reinstalled unless otherwise noted after the baseplate is installed.

The dimensional variations between otherwise identical vehicles can be considerable. While the baseplate was designed for easy installation, it may be necessary to tailor the baseplate slightly to compensate for vehicle manufacturer's tolerances.

The BX8848 Tail Light Wiring Kit is recommended for this vehicle.

NOTICE

- Handling of some cosmetic parts when installing this product may require the use of protective covers, rags, specialty tools, etc. to prevent damage.
- When using power drills be aware of the dangers of torque and drill bit length.
- When using a reciprocating saw be aware of objects behind the cutting surface.
- Use a good quality paint to spray cut edges of frame to prevent rusting.
- Be sure that **ALL** electrical connections are plugged in and accessories are functioning properly before reinstalling the fascia.
- The baseplate is computer tested to your vehicle's GVWR, exceeding this weight will void the manufacturer's warranty.
- Be sure to use a sufficient amount of Loctite® Red on all bolt threads before tightening. Tighten all bolts according to the torque chart provided.
- Dealer or installer be certain the user receives these instruction sheets.
- If the baseplate is in an accident, it must be replaced. **DO NOT** use it again! An accident can cause unseen damage and using it again could result in more damage or serious injury. **DO NOT** use the baseplate if it is damaged or missing parts.

BX2408
2012-17 Dodge Journey (No GT)
Installation Instructions

- Tools Required**
- Large Vise Grip
 - Flat Screwdriver
 - Utility Knife
 - Pliers
 - Torque Wrench
 - Drill
 - Reciprocating Saw
 - Tape Measure
 - Loctite® RED
 - 1-1/4" Holesaw
 - 13/32" Drill Bit
 - 7MM Socket
 - 7MM Wrench
 - 10MM Socket
 - 10MM Wrench
 - 13MM Socket
 - 13MM Wrench
 - 9/16" Socket
 - 9/16" Wrench
 - 11/16" Socket

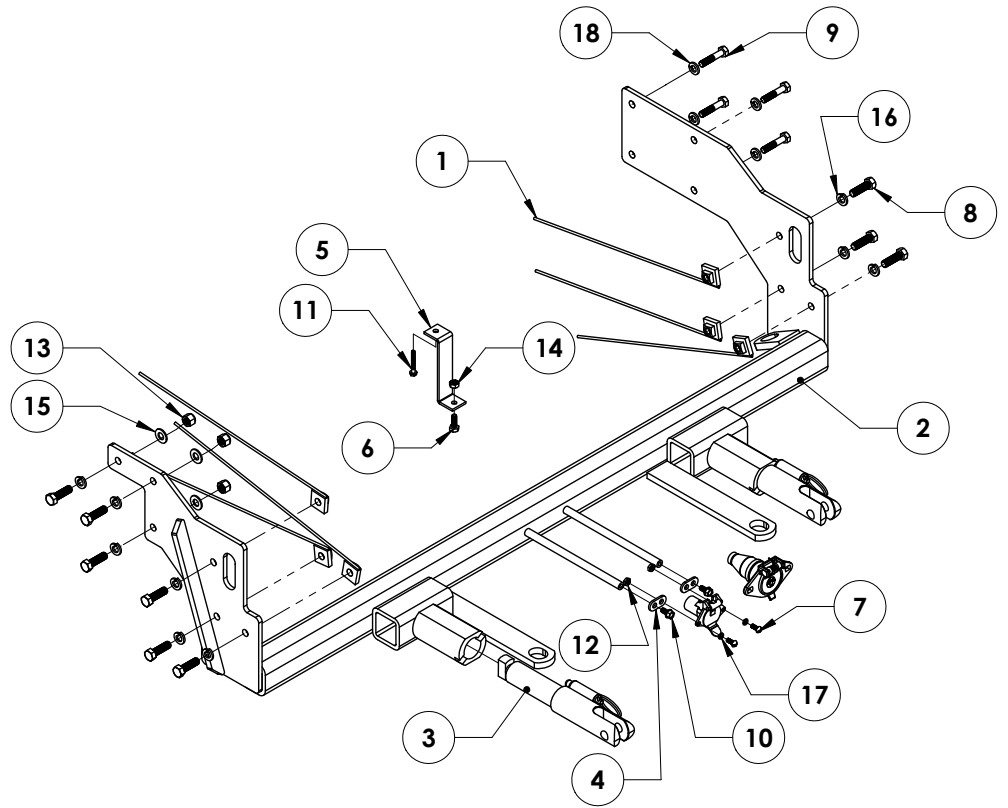

Item No.	Part No.	Description	Qty.
1	61-5208	3/8"-16 Nut Plate w/ 14" Wire	6
2	61-7143	BX2408 Baseplate	1
3	62-3469	Attachment Tab Assembly with Hole	2
4	101-5822	4 Way Connector Adapter	2
5	102-7116	Breakaway Bracket	1
6	201-0050	1/4"-20 x 3/4" Hex Head Bolt, Grade 5, ZP	1
7	201-0192	#10-32 1/2" Round Slotted Head Screw	2
8	201-0368	3/8"-16 x 1-1/4" Hex Head Bolt, Grade 5, ZP	9
9	201-0418	8MM-1.25 x 35MM Hex Head Bolt, Grade 8.8, ZP	4
10	201-0979	#12-14 x 1" Self Drilling Screw, ZP	2
11	201-0654	#10-16 x 1" Self Drilling Screw, ZP	1
12	202-0047	#10-32 Hex Nut	2
13	202-0090	3/8"-16 Hex Nylon Insert Lock Nut, ZP	3
14	202-0102	1/4"-20 Hex Nylon Nut, ZP	1
15	203-0003	3/8" Flat Washer, ZP	3
16	203-0010	3/8" Lock Washer, ZP	9
17	203-0054	#10 Lock Washer, ZP	2
18	203-0102	8MM Lock Washer, ZP	4
19	226-0049(not shown)	Class IV Safety Cables	2
20	229-0512(not shown)	1/2" Quicklink, ZP	4
21	290-0437(not shown)	Black Cap Plug Receiver	1

Important:

Use only genuine factory replacement parts on your baseplate. Do **NOT** substitute homemade or non-typical parts. If a bolt is lost or in need of replacement, for your safety and the preservation of your baseplate, be sure to use a replacement bolt of the same grade (In most cases it will be Grade 5, please reference the parts list above). Replacement parts may be ordered through your nearest Blue Ox® Dealer or Distributor. Failing to follow and/or altering these installation instructions in either installation or required equipment will void the manufacturer's warranty. Towing behind a non-motorized vehicle will void the warranty.

BX2408
2012-17 Dodge Journey (No GT)
Installation Instructions

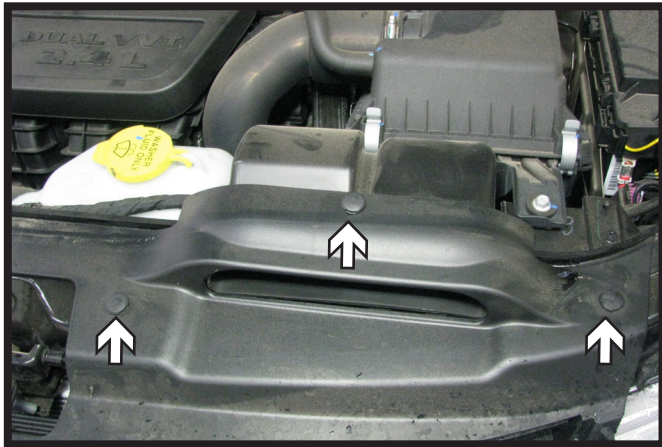

1. Remove the five (5) push pins from the top of the fascia. Three (3) on the driver side and two (2) on the passenger side.

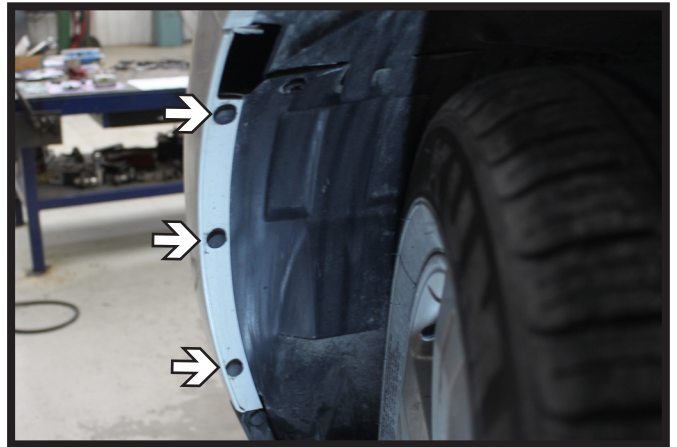

2. Remove the three (3) push pins from the wheel well. Do this on both sides of the vehicle.



3. Using a 7MM socket, remove the screw from the top edge of the fascia in the wheel well. Do this on both sides of the vehicle.

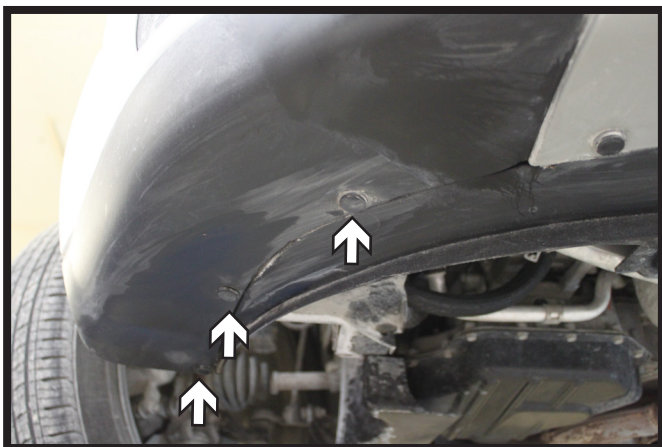

4. On the underside of the fascia, remove the three (3) push pins in the outer edge. Do this on both sides of the vehicle.

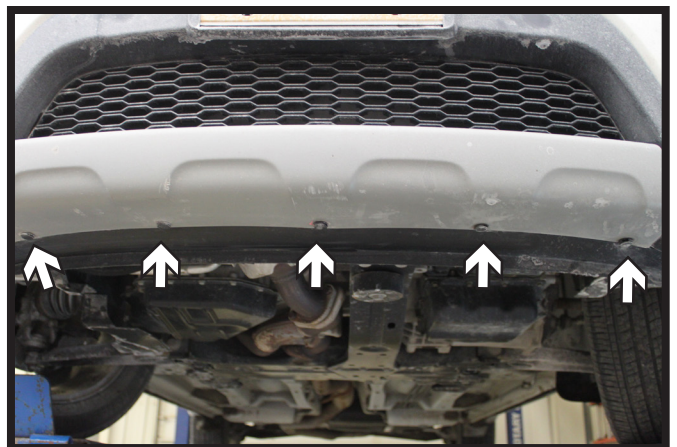

5. Continue along the underside of the fascia removing the five (5) push pins along the front.

BX2408
2012-17 Dodge Journey (No GT)
Installation Instructions



6. Lift up and pull out on the corners of the fascia to unhook it from the body. Unhook any electrical connections and set fascia aside.

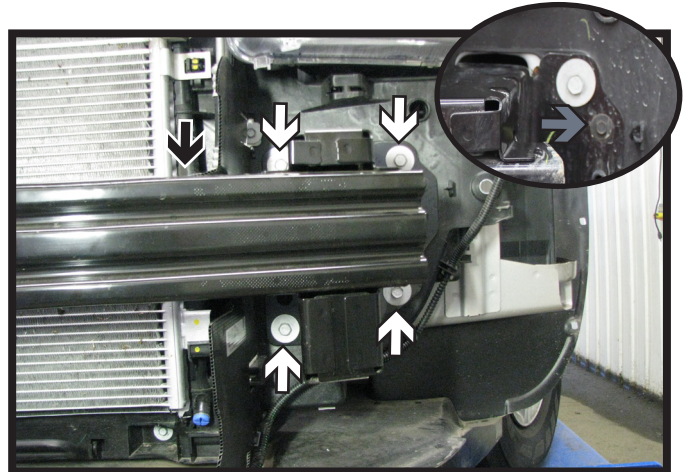

7. Using a 13MM socket, remove the four (4) bolts from the face of the bumper. Then using a 8MM socket, remove the outer bumper bolt (gray). Remove the push pin from the top of the bumper (black). Do this on both sides of the vehicle.



8. On the driver side, using a 10MM socket or wrench, remove the nuts from the battery terminals (white). Using a 13MM socket or wrench, remove the nut from the hold down post (gray). Slide the battery out of the tray and set aside.

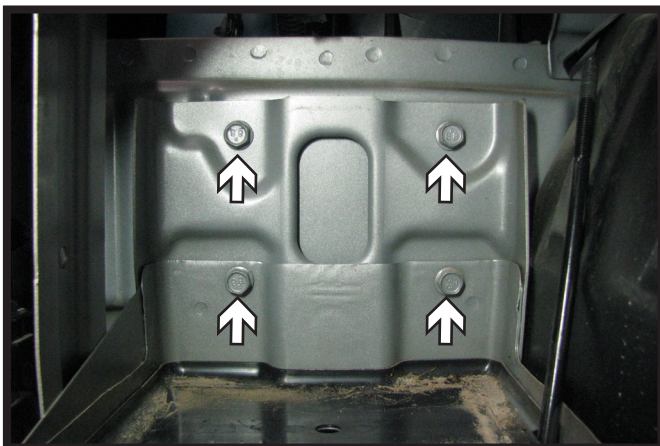

9. Using a 13MM socket, remove the four (4) bolts from the battery tray. Set the battery tray aside, the bolts will not be reused.

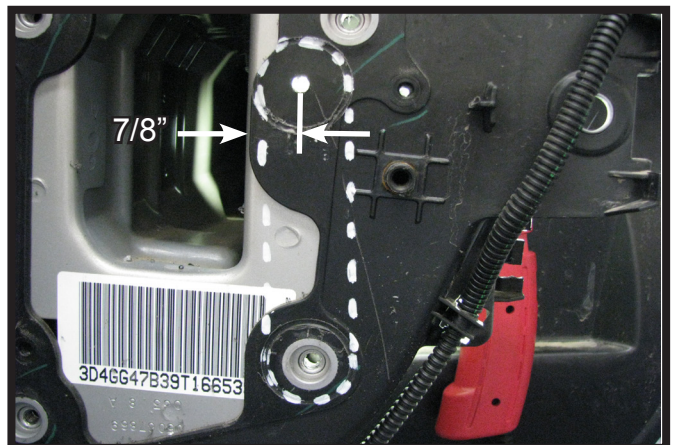

10. Measure from the inside of the frame over 7/8", then using the 1-1/4" holesaw bit trace the diameter. On the lower bumper bolt hole also trace the diameter of the holesaw bit. Connect the outside edges.

BX2408
2012-17 Dodge Journey (No GT)
Installation Instructions

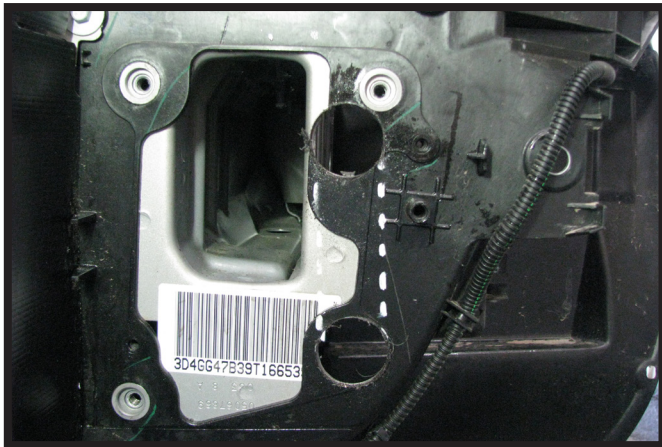

11. Using a 1-1/4" holesaw, drill out the two (2) holes. Using a reciprocating saw, connect the two (2) holes. Do this on both sides of the vehicle.

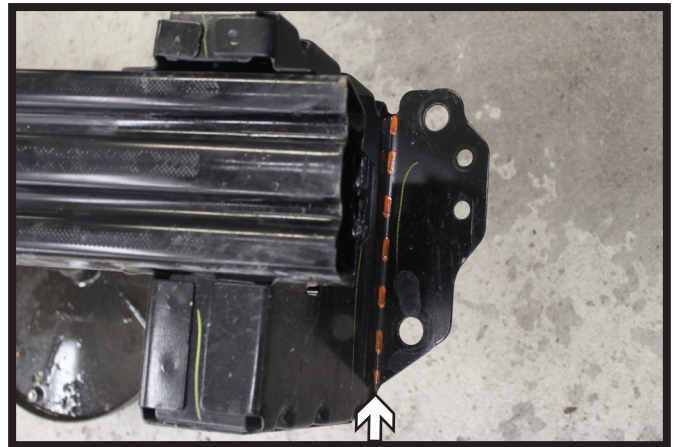

12. Using a reciprocating saw, trim off the outer flanges of the bumper flush with the sides. Do this on both sides of the bumper.

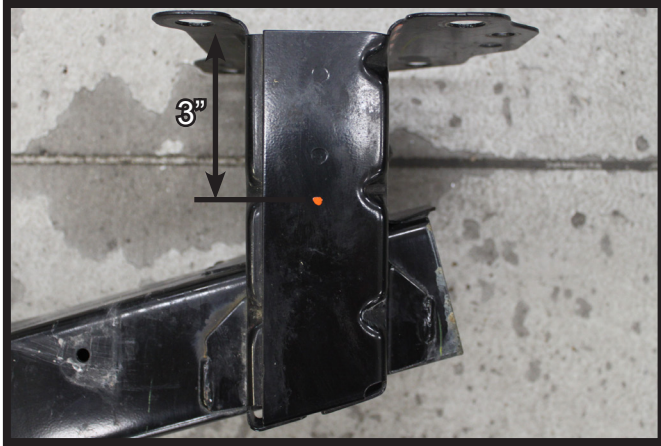

13. On the top side of the bumper, place a mark 3" from the back and centered across. Drill out using a 1-1/4" holesaw. Do this on both sides of the bumper.

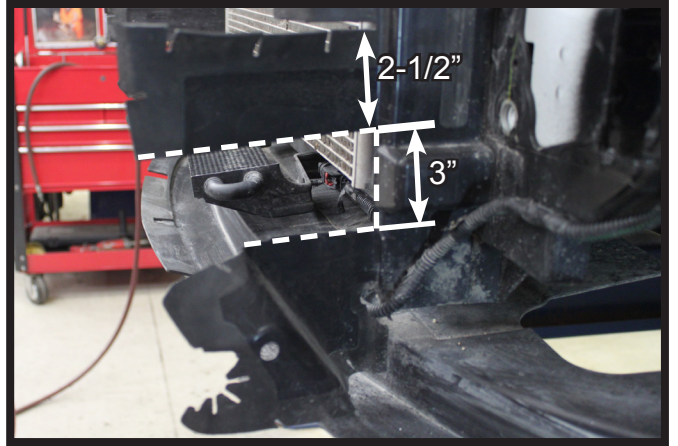

14. On the plastic deflectors, make a notch down 2-1/2" from the top and 3" high from the front to the back for baseplate clearance. Do this on both sides of the vehicle.

BX2408
2012-17 Dodge Journey (No GT)
Installation Instructions

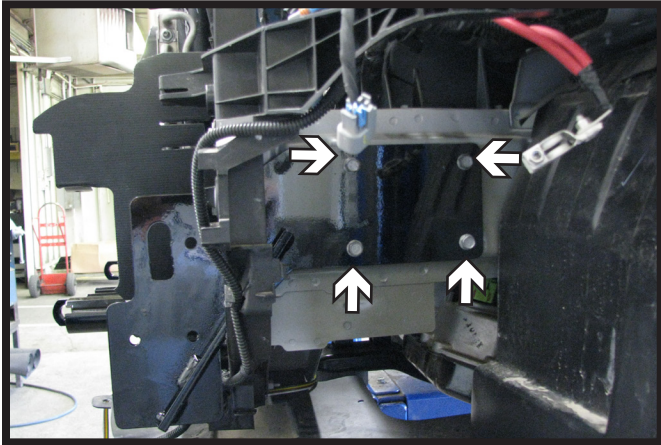

15. Slide the baseplate onto the vehicle. On the driver side, install four (4) 8MM-1.25 x 35MM bolts into the existing holes. Tighten down the bolts but **DO NOT** use loctite on threads at this time.

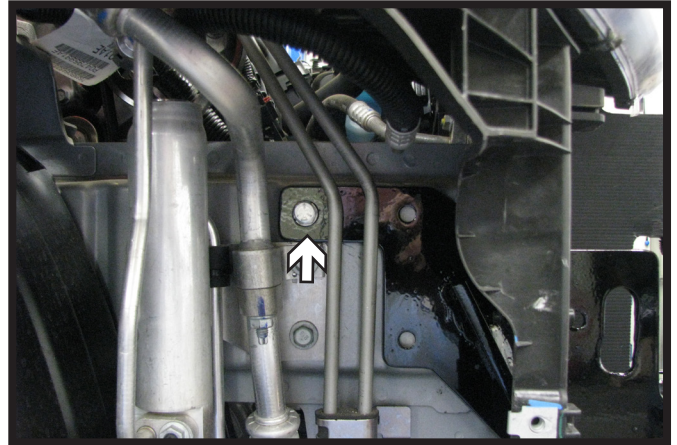

16. On the passenger side, level up the baseplate and clamp to the frame. Using a 13/32" drill bit, drill the upper left hole thru the frame. Install a 3/8"-16 x 1-1/4" bolt and lock washer into hole. From the inside of the frame install a 3/8" flat washer and 3/8"-16 lock nut onto the bolt and tighten. Drill the remaining two (2) holes and install the 3/8" fasteners.

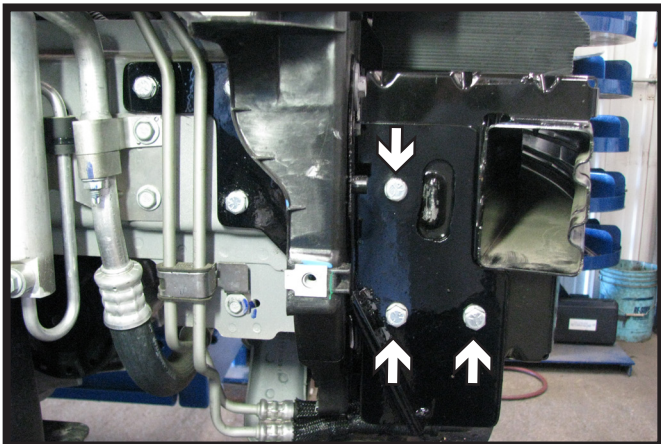

17. Reinstall the bumper onto the vehicle using the existing fasteners. Using a 13/32" drill bit, drill the three (3) holes thru the bumper. Install a 3/8"-16 x 1-1/4" bolt, 3/8" lock washer and 3/8"-16 nut plate into each of the holes using the 1-1/4" hole in the top of the bumper for access. Do this on both sides of the vehicle.

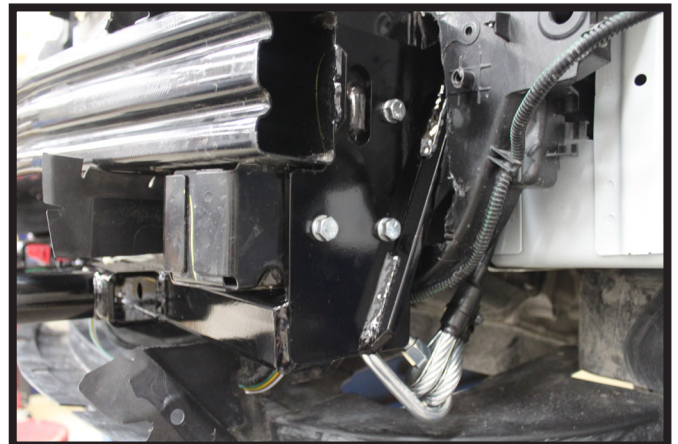

18. Attach the permanent baseplate safety cables to the provided convenience link on the baseplate. The photo above shows the recommended installation of the cables to frame of vehicle. Additional options may interfere with suggested mounting; in this case, secure the cables to a solid piece of the frame as described in the instructions included with the permanent baseplate safety cables. Be sure the safety cables do not rub against any hoses or moving parts. Do this on **BOTH** sides of the vehicle.

BX2408
2012-17 Dodge Journey (No GT)
Installation Instructions



19. On the driver side, remove the four (4) 8MM bolts from the baseplate. Reinstall the battery tray with the 8MM bolts and the 8MM lock washers provided with loctite. Reinstall the battery and terminal connections.



20. Hold the fascia as close to it's original position, mark and trim the lower grille as needed for baseplate clearance. Reinstall the fascia.

CUSTOMER SERVICE COMMITMENT

Blue Ox® is committed to providing you with exceptional customer care throughout your lifetime with our products. Our team is here to assist you with any questions you may have regarding the performance of your product. Simply call (402) 385-3051 and you can speak with our technical service team.

Additionally, please visit our website to see which rallies our Destination America team will be attending. For a nominal fee, our service technician will service your towing system to ensure it's in proper working condition. Also, as a commitment to our customers, should you visit our factory, you can stay at our full service Blue Ox® campground at no charge along with enjoying a factory tour.

Again, thank you for being our customer and for the confidence you have shown in the performance of our products. It is because of customers like you we enjoy the success we have today.

© 2015 Blue Ox
One Mill Road, Industrial Park
Pender, Nebraska 68047
Phone: (402) 385-3051
Fax: (402) 385-3360
www.blueox.com

General Information

1. Ensure that your product(s) are registered online at www.blueox.com. It is crucial to register your product(s) so that you may be alerted of product offerings, updates, upgrades, maintenance and safety bulletins, and/or recalls.
2. **It is the owner's responsibility to inspect all towing equipment for cracked welds, missing or worn parts and loose bolts before each towing trip.** Be sure to use Loctite® Red on all bolts and tighten to the recommended specifications.
3. **It is the owner's responsibility to hook up all towing equipment per manufacturer's instructions/recommendations.**
4. Remove the attachment tabs when not in use (if applicable).

Notice To Baseplate Installer

1. It is YOUR responsibility to watch for:

- Oil cooler and air conditioner lines
- Electrical wires and hoses
- Missing parts or attaching points on the frame

** If the baseplate is improperly installed and is against a wire or hose, it could cause fluid leaks or electrical shorts some time after the actual baseplate installation.

Permanent Baseplate Safety Cable Installation

Permanent baseplate safety cables are strongly recommended when towing a vehicle with a tow bar. The principle function of the permanent baseplate safety cables is to prevent the towed vehicle from breaking loose in the event the connection between the frame of the towed vehicle and the baseplate fails or becomes disconnected. The cables must be connected from the baseplate to the frame rail or cross member of the vehicle's frame. The illustrations below show the possible arrangements recommended by Blue Ox®. Each permanent baseplate safety cable must have an adequate weight rating for the towing system. The weight rating of the two (2) cables together will not qualify.

Do not mount the permanent baseplate safety cables against wires, hoses or brake lines.

These permanent baseplate safety cables should remain installed as long as the baseplate is installed on the vehicle. Permanent baseplate safety cables are to be used in conjunction with, and NOT a replacement for legally required safety cables attaching the towed vehicle to the towing vehicle.

OPTION #1



OPTION #2

