

Please read **BOTH** these Installation Instructions and the General Instructions before attempting to install or operate this equipment.

- Blue Ox® towing products and accessories are intended to be installed by Blue Ox® Dealers who are familiar with our products and have the necessary equipment and knowledge to do "fit work". When necessary Blue Ox® Dealers can be found at [www.blueox.us](http://www.blueox.us) or by contacting our Customer Care Department at (402) 385-3051 or toll free at (888) 425-5382.
- Many Blue Ox® baseplates are designed to use existing holes and hardware to mount the baseplate to the towed vehicle. Even though bolts are there, do not assume they are adequate for baseplate mounting. Always use hardware supplied in the hardware kit and existing hardware specified in the Baseplate Installation Instructions.

Attachment Tab Height: 13 1/2"

Attachment Tab Width: 18"

### Bolt Torque Specifications

Torque in Foot-Pounds per Metric Bolts

Bolt Size	Grade 8.8	Grade 10.9
6MM	6	8
8MM	16	22
10MM	31	40
12MM	54	70
14MM	89	117

Confirm the towability and pre-towing procedures for your vehicle with the owner's manual or contact the vehicle's manufacturer for specific towing procedures. You can also contact REMCO for additional information at 1(800)228-2481.

### Bolt Torque Specifications

Torque in Foot-Pounds per Inch Bolts

Bolt Size	Grade 5	Grade 8
1/4"	10	14
5/16"	19	29
3/8"	33	47
7/16"	54	78
1/2"	78	119
5/8"	154	230



## **! WARNING**

Failure to read and follow these instructions could result in separation of the towed vehicle from the tow bar, causing property damage, loss of towed vehicle, personal injury or death.

# BX2241 2005 Honda Civic SI Installation Instructions

## Parts List

Ref.No.	Qty.	Part #	Description
1	1	61-6177	Weldment, Baseplate BX2241
2	6	61-5208	3/8" Nut Plate with Wire
3	6	201-0440	3/8-16 x 1 1/2" Bolt, Grade 5, ZP
4	2	201-0443	3/8-16 x 1" Bolt, Grade 5, ZP
5	8	203-0010	3/8" Lock Washer, ZP
6	2	202-0003	3/8-16 Hex Nut, ZP
7	1	201-0702	6MM-1 x 45MM Hex Bolt, Grade 8.8, ZP
8	1	203-0001	1/4 Flat Washer, ZP
9	2	201-0979	#12-14 x 1" Self Drilling Screw, ZP
10	2	201-0192	#10-32 x 1/2 Slot, Rd. Hd. Screw
11	2	203-0054	#10 Lock Washer
12	2	202-0047	#10-32 Hex Nut
13	2	101-5822	Adapter, 4 Way Connector
14	2	62-3468	Attachment Tab Assembly, SB/SF, ZP
	2	226-0046	Baseplate Safety Cable, 36" CL III (Not Shown)
	2	229-0359	Quicklink, 3/8, ZP (Not Shown)
	2	290-0437	Cap Plug (Not Shown)

## Tools Required

10MM Socket	Vise Grips
12MM Socket	Phillips Screwdriver
8MM Socket	Reciprocating Saw
13/32" Drill Bit	Utility Knife
9/16" Socket	Tape Measure
	Loctite Red

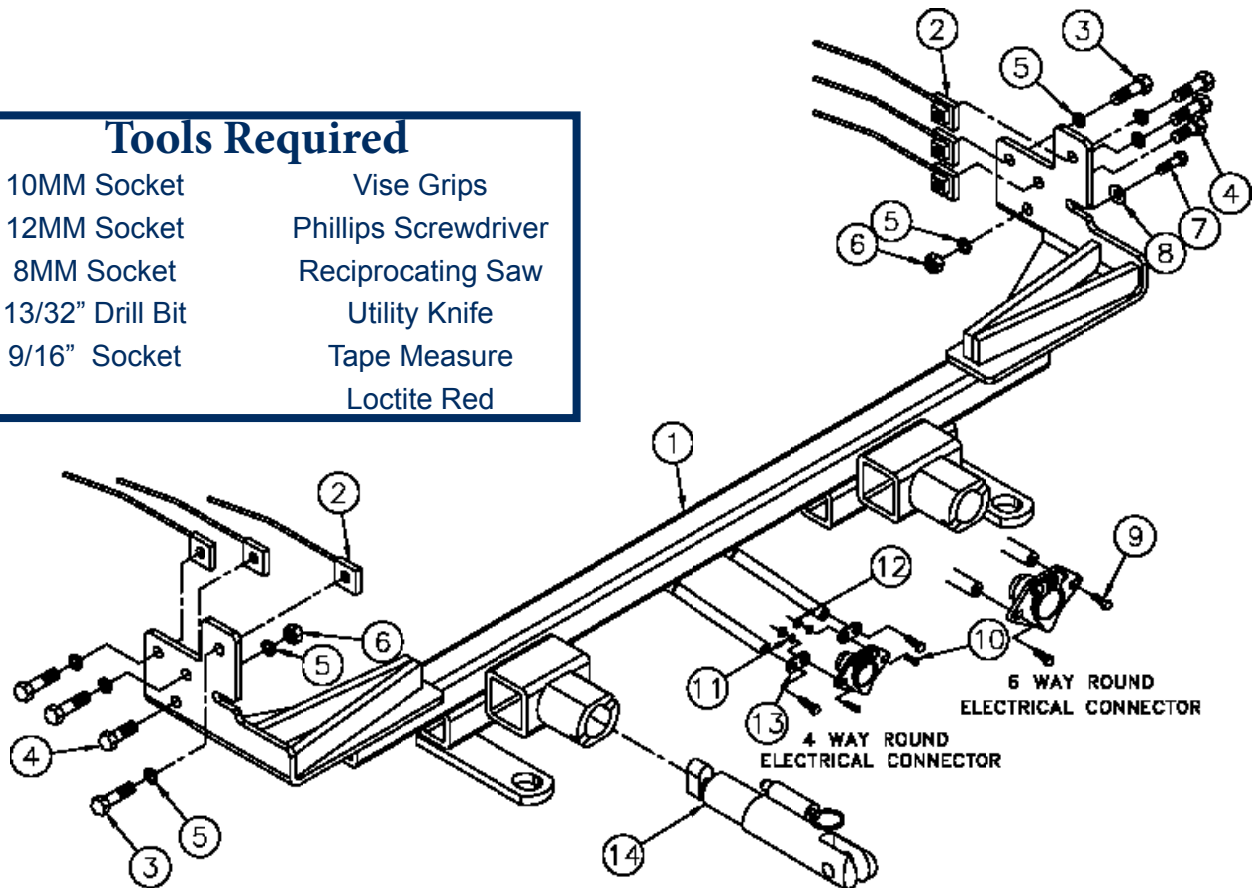

### Important:

Use only genuine factory replacement parts on your baseplate. Do NOT substitute homemade or non-typical parts. If a bolt is lost or in need of replacement, for your safety and the preservation of your baseplate, be sure to use a replacement bolt of the same grade. In most cases it will be Grade 5. Please reference the parts list above. Replacement parts may be ordered through your nearest Blue Ox® dealer or distributor, or call our 24/7 Customer Care Team at (402)385-3051 or toll free (888) 425-5382.

# BX2241

## 2005 Honda Civic SI

### Installation Instructions

#### Attachment Tabs:

Motorhome mount tow bars are recommended for use with this baseplate. Due to the design of the removable tabs, the RangeFinder II, Adventurer, and Ambassador tow bars can not be used. The Acclaim tow bar may be used, but will not fold and store on the front of the vehicle. Adapters, except the BX88333 and BX88151, can not be used with this baseplate.

#### Instructions:

The front fascia, headlight assembly, metal bumper and windshield washer reservoir are removed and reinstalled during baseplate installation. Drilling is required. Trimming of the fascia grille styles is required.

The dimensional variations between otherwise identical vehicles can be considerable. Although the baseplate was designed for easy installation, it may be necessary to tailor the baseplate slightly to compensate for auto manufacturer's tolerances. These minor adjustments may include filing a hole slightly, bending electrical rods, and/ or bending end plates.

The BX8848, 4 Diode Wiring Kit is recommended for this vehicle.



1. Remove four pushpins from the top of fascia. Remove the black plastic from the top of the fascia. Set plastic and pushpins aside to reinstall later.



2. Using an 8MM socket, remove one bolt from the front fascia, inside the wheel well. Do this to both sides of the vehicle. Set bolts aside to reinstall later.



# BX2241

## 2005 Honda Civic SI

### Installation Instructions



3. Remove one Phillips screw, indicated by the grey arrow in the photo above, and two pushpins, indicated by the white arrows in the photo above, on the underneath corner of fascia – just forward of the front tire. Do this to both sides of the vehicle. Set screw and pushpins aside to reinstall later.



4. Remove four additional pushpins from underneath of fascia. Set pushpins aside to reinstall later. Disconnect fog lights and set aside to reinstall later (if applicable). Pull fascia forward and set aside to reinstall later.



5. Using a 10MM socket, remove one metric bolt from above the headlight assembly, as indicated by the grey arrow in the photo above. Remove one pushpin, as indicated by the white arrow in the photo above. Do this to both sides of the vehicle. Set bolts and pushpins aside to reinstall later.



6. Using a 10MM socket, remove one metric bolt below the headlight assembly, near the radiator. Do this to both sides of the vehicle. Set bolts aside to reinstall later.

# BX2241

## 2005 Honda Civic SI

### Installation Instructions



7. Using a 10MM socket, remove one metric bolt below the headlight assembly's turn signal. Do this to both sides of the vehicle. Unplug the headlight assembly. Set the bolts and headlight assemblies aside to reinstall later.

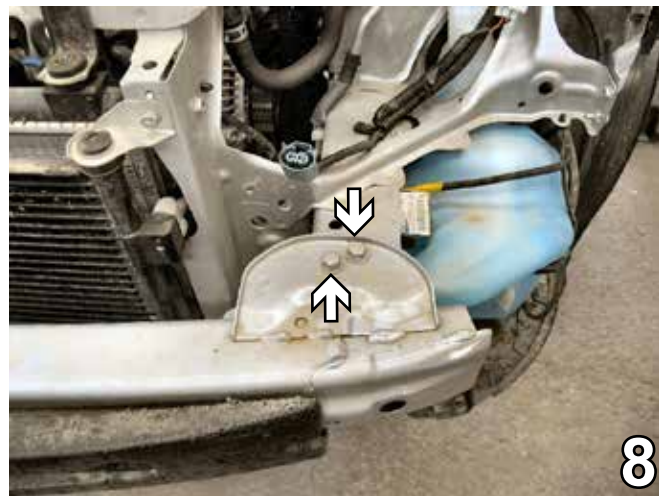

8. Using a 12MM socket, remove two metric bolts from above the metal bumper. Do this to both sides of the vehicle. Set bolts aside to reinstall later.

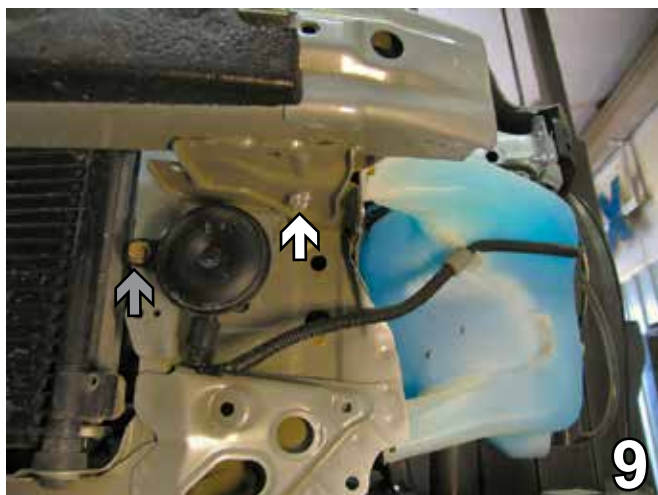

9. Using a 12MM socket, remove one metric bolt found underneath the bumper bracket, as indicated by the white arrow in the photo above. Do this to both sides of the vehicle. Pull metal bumper forward. Set metal bumper and bolts aside to reinstall later. Bend the horn bracket, as indicated by the grey arrow in the photo above, in toward the rear of the vehicle to allow enough room for the baseplate to be installed. Do this to both sides of the vehicle.

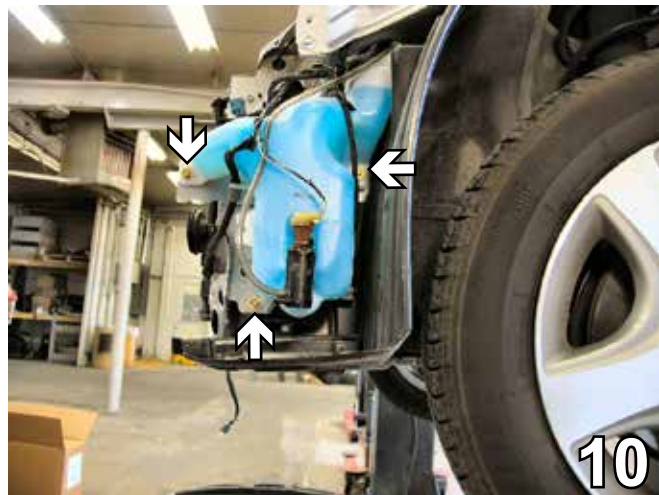

10. Using a 10MM socket, remove three metric bolts from the windshield washer reservoir. Unplug electrical connections, disconnect and plug water line. Set reservoir and bolts aside to reinstall later.

**CAUTION:** To prevent damage to the horn, insure it does **NOT** come into contact with anything else.



# BX2241

## 2005 Honda Civic SI

### Installation Instructions

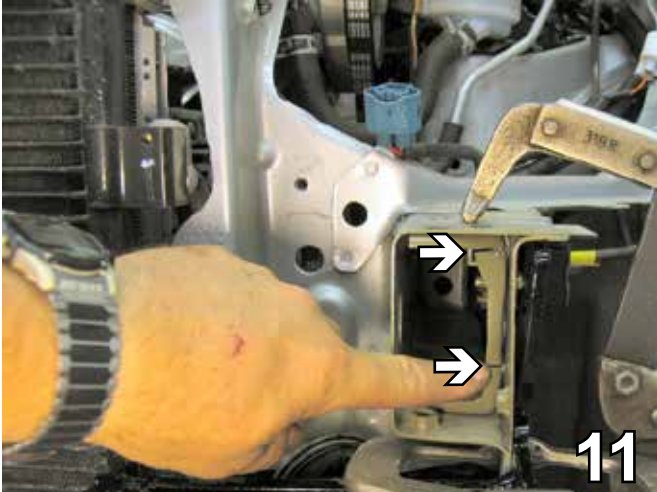

11. Using a reciprocating saw, make one cut on the top of the outside edge of the ribbing inside the frame rail and one cut on the bottom of the outside edge of the ribbing inside the frame rail. Do this to both sides of the vehicle.

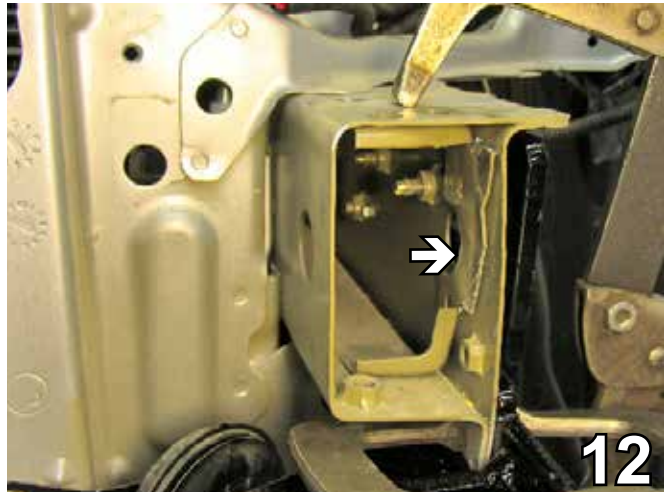

12. Bend the ribbing so that it is flat against the frame rail. Do this to both sides of the vehicle.



13. Turn metal bumper upside down. Using the vise grips, flatten the edge of the metal bumper bracket. Do this to both sides of the metal bumper bracket. This prevents the edge from coming into contact with the baseplate.

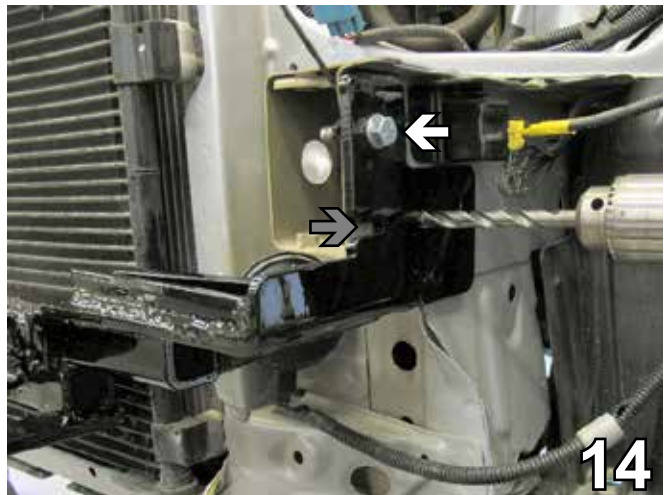

14. On the driver's side, align front slot of baseplate endplate with the existing windshield reservoir hole and clamp into place with the vise grips, as indicated by the grey arrow in the photo above. Maintaining a level position, align and clamp baseplate in place on the passenger's side. Using the baseplate as a template, drill the top hole in the baseplate end plate with the 13/32" drill bit. Insert the 3/8-16 nut plate into the frame to align with the drill hole. Insert the 3/8-16 x 1 1/2" hex bolts and 3/8" lock washers and tighten. Do this to both sides of the vehicle.

**\*\*BE SURE TO USE LOCTITE® RED ON ALL BOLTS BEFORE TIGHTENING. TIGHTEN ALL BOLTS ACCORDING TO THE TORQUE CHART ON THE FRONT PAGE OF THESE INSTRUCTIONS OR ON PAGE 3 OF THE BASEPLATE TOWING GENERAL INSTRUCTIONS.**

Align the fascia to its original position and verify the attachment tabs come through the fascia's upper opening. Adjust the tilt of the baseplate accordingly until a proper fit is achieved.

# BX2241

## 2005 Honda Civic SI

### Installation Instructions



15. Using the baseplate as a template, drill the remaining holes in the baseplate end plates with the 13/32" drill bit. Do this to both sides of the vehicle.

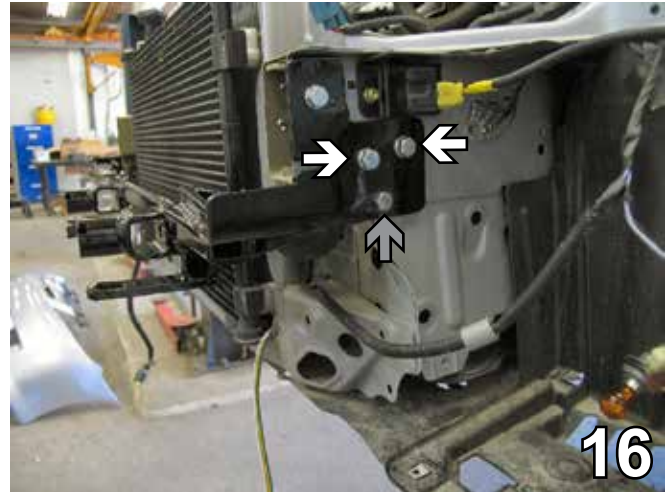

16. Insert the 3/8-16 nut plates into the end of the frame rail and align with the remaining two upper drilled holes. Insert the 3/8-16 x 1 1/2" hex bolts and 3/8" lock washers and tighten. Do this to both sides of the vehicle.

**\*\*BE SURE TO USE LOCTITE® RED ON ALL BOLTS BEFORE TIGHTENING. TIGHTEN ALL BOLTS ACCORDING TO THE TORQUE CHART ON THE FRONT PAGE OF THESE INSTRUCTIONS OR ON PAGE 3 OF THE BASEPLATE TOWING GENERAL INSTRUCTIONS.**

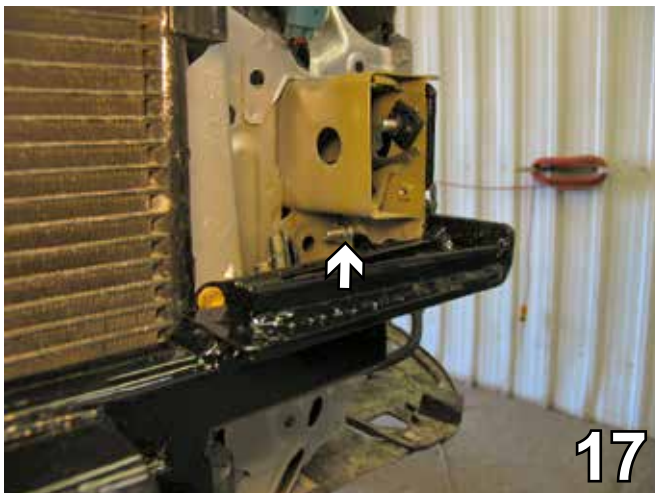

17. Insert 3/8-16 x 1" hex bolt into the lower hole of the baseplate end plate. Install 3/8" lock washer and 3/8-16 hex nut and tighten. Do this to both sides of the vehicle.



18. Reinstall metal bumper using existing metric bolts in upper bolt hole locations only. The lower metric bolts will not be reinstalled. Do this to both sides of the vehicle.



BX2241  
2005 Honda Civic SI  
Installation Instructions



19. Reinstall the windshield washer reservoir to its original position using the 6MM-1 x 45MM hex bolt and 1/4" flat washer in front bolt location, as indicated by the arrow in the photo above. Install and tighten the remaining two existing bolts.

**\*\*BE SURE TO USE LOCTITE® RED ON ALL BOLTS BEFORE TIGHTENING. TIGHTEN ALL BOLTS ACCORDING TO THE TORQUE CHART ON THE FRONT PAGE OF THESE INSTRUCTIONS OR ON PAGE 3 OF THE BASEPLATE TOWING GENERAL INSTRUCTIONS.**



20. On the backside of the fascia, use a utility knife to start a cut approximately 1/2" from the grille edge, then cut upward approximately 3/4", as indicated by photo 20-A. Angle the cut downward approximately 2 3/4", as indicated by photo 20-B. Do this to both sides of the fascia.

**Be sure that ALL electrical connections are plugged in properly and functioning BEFORE installing the fascia.**



21. Using a utility knife, cut and remove the vertical grille style from the outside edge of the upper grille opening. Do this to both sides of the fascia.

22. Reinstall headlights and fog lights (if applicable) to their original location.

23. Reinstall front fascia. Be sure to tighten all bolts and screws and install all pushpins.



# BX2241

## 2005 Honda Civic SI

### Installation Instructions

#### **DEALER or INSTALLER:**

**Be certain the user receives the instruction sheets for their products.**

Install the tow bar and safety cables according to the instructions provided in their packages. When demonstrating this to the customer, be sure to include all the contents and packages.

Do **NOT** substitute other devices if the tow bar pins and clips are misplaced.

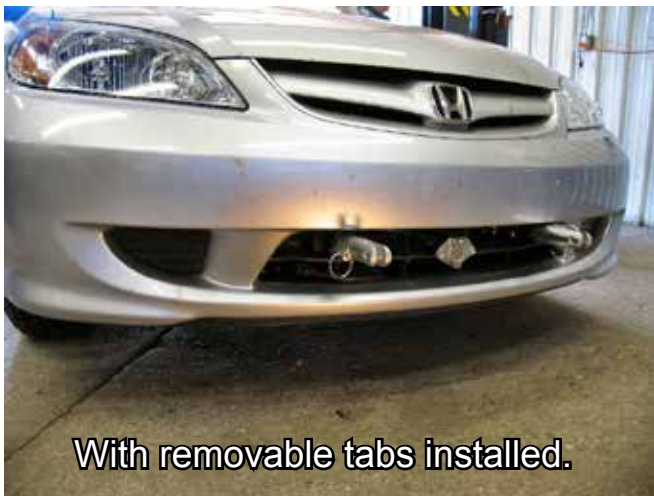

**With removable tabs installed.**



**Without removable tabs installed.**

#### **CUSTOMER SERVICE COMMITMENT**

Blue Ox is committed to providing you with exceptional customer care throughout your lifetime with our products. Our team is here to assist you with any questions you may have regarding the performance of your product. Simply call 1-800-228-9289 and you can speak with our customer care team.

Additionally, please visit our website to see which rallies our Destination America team will be attending. For a nominal fee, our service technician will service your towing system to ensure it's in proper working condition. Also as a commitment to our customers, should you visit our factory you can stay at our full service Blue Ox campground at no charge along with enjoying a factory tour.

Again thank you for being our customer and for the confidence you have shown in the performance of our products. It is because of customers like you we enjoy the success we have today.



© 2005 Blue Ox  
One Mill Road, Industrial Park  
Pender, Nebraska 68047  
Phone: (402) 385-3051  
Fax: (402) 385-3360  
[www.blueox.us](http://www.blueox.us)  
10/23/08

# General Information

1. Ensure that your product(s) are registered online at [www.blueox.com](http://www.blueox.com). It is crucial to register your product(s) so that you may be alerted of product offerings, updates, upgrades, maintenance and safety bulletins, and/or recalls.
2. **It is the owner's responsibility to inspect all towing equipment for cracked welds, missing or worn parts and loose bolts before each towing trip.** Be sure to use Loctite® Red on all bolts and tighten to the recommended specifications.
3. **It is the owner's responsibility to hook up all towing equipment per manufacturer's instructions/recommendations.**
4. Remove the attachment tabs when not in use (if applicable).

## Notice To Baseplate Installer

### 1. It is YOUR responsibility to watch for:

- Oil cooler and air conditioner lines
- Electrical wires and hoses
- Missing parts or attaching points on the frame

\*\* If the baseplate is improperly installed and is against a wire or hose, it could cause fluid leaks or electrical shorts some time after the actual baseplate installation.

## Permanent Baseplate Safety Cable Installation

Permanent baseplate safety cables are strongly recommended when towing a vehicle with a tow bar. The principle function of the permanent baseplate safety cables is to prevent the towed vehicle from breaking loose in the event the connection between the frame of the towed vehicle and the baseplate fails or becomes disconnected. The cables must be connected from the baseplate to the frame rail or cross member of the vehicle's frame. The illustrations below show the possible arrangements recommended by Blue Ox®. Each permanent baseplate safety cable must have an adequate weight rating for the towing system. The weight rating of the two (2) cables together will not qualify.

***Do not mount the permanent baseplate safety cables against wires, hoses or brake lines.***

These permanent baseplate safety cables should remain installed as long as the baseplate is installed on the vehicle. Permanent baseplate safety cables are to be used in conjunction with, and NOT a replacement for legally required safety cables attaching the towed vehicle to the towing vehicle.

### OPTION #1

Permanent Baseplate Safety Cables to Cross Member or Frame of Towed Vehicle.

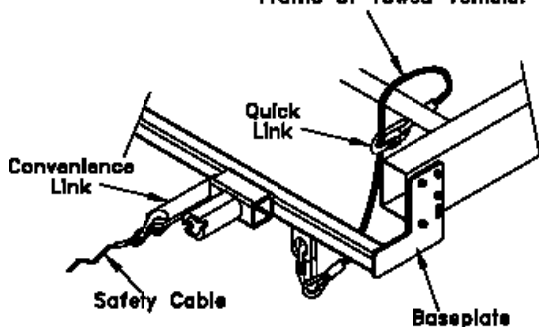

### OPTION #2

Permanent Baseplate Safety Cables to Cross Member or Frame of Towed Vehicle.

