



BX2170 2000 Ford Ranger (2WD/4WD, Not Northland) Installation Instructions

Serial Number

Attachment Tab Height: 17"

Attachment Tab Width: 24"

Please read BOTH these Installation Instructions and the General Instructions before attempting to install or operate this equipment.

Bolt Torque Specifications
Torque in Foot-Pounds per Metric Bolts

Bolt Size	Grade 8.8	Grade 10.9
6MM	6	8
8MM	16	22
10MM	31	40
12MM	54	70
14MM	89	117

1. Blue Ox® towing products and accessories are intended to be installed by Blue Ox® Dealers who are familiar with our products and have the equipment necessary and knowledge to do "fit work". When necessary Blue Ox® Dealers can be found at www.blueox.us or by contacting our 24/7 Customer Care Department at (402) 385-3051 or toll free (888) 425-5382.

Bolt Torque Specifications
Torque in Foot-Pounds per Inch Bolts

Bolt Size	Grade 5	Grade 8
1/4"	10	14
5/16"	19	29
3/8"	33	47
7/16"	54	78
1/2"	78	119
5/8"	154	230

2. Many Blue Ox® Baseplates are designed to use existing holes and hardware to mount the baseplate to the towed vehicle. Even though bolts are there, do not assume they are adequate for baseplate mounting. Always use hardware supplied in the hardware kit and existing hardware specified in the Baseplate Installation Instructions.

Confirm the towability and pre-towing procedures for your vehicle with the owner's manual or contact the vehicle's manufacturer for specific towing procedures. You can also contact REMCO for additional information at 1(800)228-2481.

! WARNING

Failure to read and follow these instructions could result in separation of the towed vehicle from the tow bar, causing property damage, loss of towed vehicle, personal injury or death.

BX2170 2000 Ford Ranger Installation Instructions

Parts List

Ref. No.	Qty.	Part #	Description
1	1	61-5156	Weldment, Baseplate, BX2135/BX2170
2	1	101-6609	Plate Support, DS BX2135
3	1	101-6610	Plate Support, PS BX2135
4	4	61-5159	Weldment, 1/2" Nut Plate
5	2	61-4029	Weldment, 1/2" Nut Plate
6	4	61-5208	Weldment, 3/8" Nut Plate, With Wire
7	6	201-0051	1/2-13 x 1 1/2" Hex Bolt, Grade 5
8	6	203-0012	1/2" Lock Washer
9	4	203-0005	1/2" Flat Washer
10	4	201-0368	3/8-16 x 1 1/4" Hex Bolt, Grade 5, ZP
11	4	201-0440	3/8-16 x 1 1/2" Hex Bolt, Grade 5, ZP
12	2	201-0010	3/8" Lock Washer
13	4	202-0003	3/8-16 Hex Nut, ZP
14	2	201-0979	#12-14 x 1" Self Drilling Screw, ZP
15	2	201-0192	#10-32 x 1/2" Slot, Rd. Hd. Screw
16	2	203-0054	#10 Lock Washer
17	2	202-0047	#10 Hex Nut
18	2	101-5822	Adapter, 4 way Connector
19	2	226-0049(not shown)	Class III Safety Cables

Tools Required

18MM Socket	13/32" Drill Bit
10MM Socket	17/32" Drill Bit
3/4" Socket	LOCTITE Red
9/16" Socket	

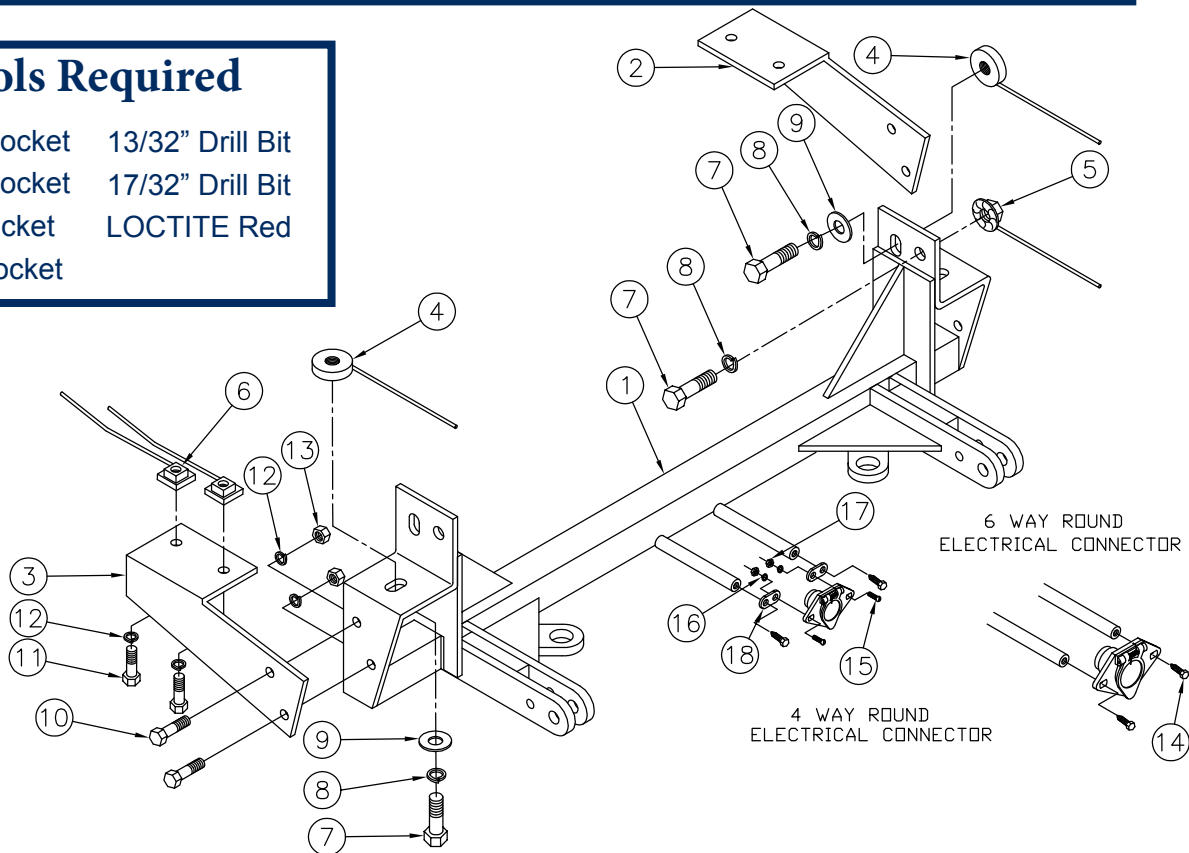

Important:

Use only genuine factory replacement parts on your baseplate. Do NOT substitute homemade or non-typical parts. If a bolt is lost or in need of replacement, for your safety and the preservation of your baseplate, be sure to use a replacement bolt of the same grade (In most cases it will be Grade 5, please reference the parts list above). Replacement parts may be ordered through your nearest Blue Ox® Dealer or Distributor, or call our 24/7 Customer Care Team at (402)385-3051.

BX2170

2000 Ford Ranger

Installation Instructions

Standard Tab Spacing Guidelines:

To use certain adapters or a RangeFinder II tow bar in conjunction with standard tab baseplates an additional 5/16" hole must be drilled in the attachment tabs. The Ambassador tow bar will require an adapter for attachment tabs that are not 24" wide. The Adventurer tow bar will require an adapter for attachment tabs that are less than 24" wide. The Acclaim tow bar will not fold and store without the use of an adapter on vehicles with attachment tabs less than 24" wide. The BX88152 adapter cannot be used with this baseplate.

Instructions:

Installation of the baseplate requires removing and reinstalling the bumper and belly pan. Drilling is required. Trimming of the belly pan and fascia is required.

The dimensional variations between otherwise identical vehicles can be considerable. While the baseplate was designed for easy installation, it may be necessary to tailor the baseplate slightly to compensate for auto manufacturer's tolerances. These minor adjustments may include filing a hole slightly, bending electrical rods, and/ or bending end plates.

The BX8869 Bulb and Socket wiring kit is recommended for this vehicle.

Installation Instructions

1. The baseplate mounts to the frame using six bolts which are included with the baseplate. The lower plastic air dam needs to be trimmed for the attachment tabs to protrude.
2. There are four hex nuts that hold the bumper on the end of the frame rails. Remove the bolts with the 18MM socket and set the bumper aside to be reinstalled later.
3. The baseplate fits on the inside and bottom of the frame rails near the front of the frame. There are slots in the frame that will match up to the slots in the end of pieces of the baseplate. Hold the baseplate up in position and then mark the location of the two round holes in the side of the end pieces. Remove the baseplate and drill 17/32" holes in these locations.
4. Position the baseplate on the frame again and start the bolts. The four nut plates supplied are to be used on the bolts going into the slotted holes and the nut wires for the two drilled holes. Use the flat washers to cover the slots. When all bolts are started, tighten completely. Be sure to apply LOCTITE Red to all bolts before tightening. Tighten all bolts according to the Torque Chart in the General Instructions sheet.

BX2170

2000 Ford Ranger

Installation Instructions

5. Align the holes of the plate support to the outside of the baseplate end, insert the 3/8" hex bolt, fasten the lock washer and hex nut, according to the drawing on page 2. Do this to both sides of the vehicle. Using the plate support as a template, drill holes into the bottom of the frame with the 13/32" drill bit. Do this to both sides of the vehicle. Tighten all bolts according to the torque chart found on page 3 of the Baseplate General Towing Instructions sheet.
6. Hold the bumper up to its original position, mark where the attachment tabs will protrude out, trim the plastic on the front bumper and reinstall the bumper.

Install the tow bar and safety cables according to the instructions included in their packages.

Do not substitute other devices if the tow bar pin and clip are lost.

DEALER OR INSTALLER: BE CERTAIN THE USER RECEIVES THE INSTRUCTION SHEETS.

Customer Service Commitment

Blue Ox® is focused on providing exemplary customer service, as observed in our mission statement and guiding principles. In accordance with this objective, Blue Ox® is proud to provide services such as repairs and general maintenance of Blue Ox® products at over 150 RV Rallies. Look for our Destination America or Blue Ox® Racing service crews at the next rally or race that you attend. If you were not present, you will find an informative, personalized note explaining any services that may have been performed to your Blue Ox® products.

Blue Ox® also offers educational seminars at rallies and through our Parks and Resort teams. In addition, Blue Ox® customers visiting our factory may take advantage of the well-equipped Blue Ox® RV park at no charge to you, our valued and appreciated customer.



General Information

1. Ensure that your product(s) are registered online at www.blueox.com. It is crucial to register your product(s) so that you may be alerted of product offerings, updates, upgrades, maintenance and safety bulletins, and/or recalls.
2. **It is the owner's responsibility to inspect all towing equipment for cracked welds, missing or worn parts and loose bolts before each towing trip.** Be sure to use Loctite® Red on all bolts and tighten to the recommended specifications.
3. **It is the owner's responsibility to hook up all towing equipment per manufacturer's instructions/recommendations.**
4. Remove the attachment tabs when not in use (if applicable).

Notice To Baseplate Installer

1. **It is YOUR responsibility to watch for:**

- Oil cooler and air conditioner lines
- Electrical wires and hoses
- Missing parts or attaching points on the frame

** If the baseplate is improperly installed and is against a wire or hose, it could cause fluid leaks or electrical shorts some time after the actual baseplate installation.

Permanent Baseplate Safety Cable Installation

Permanent baseplate safety cables are strongly recommended when towing a vehicle with a tow bar. The principle function of the permanent baseplate safety cables is to prevent the towed vehicle from breaking loose in the event the connection between the frame of the towed vehicle and the baseplate fails or becomes disconnected. The cables must be connected from the baseplate to the frame rail or cross member of the vehicle's frame. The illustrations below show the possible arrangements recommended by Blue Ox®. Each permanent baseplate safety cable must have an adequate weight rating for the towing system. The weight rating of the two (2) cables together will not qualify.

Do not mount the permanent baseplate safety cables against wires, hoses or brake lines.

These permanent baseplate safety cables should remain installed as long as the baseplate is installed on the vehicle. Permanent baseplate safety cables are to be used in conjunction with, and NOT a replacement for legally required safety cables attaching the towed vehicle to the towing vehicle.

Option #1

(Baseplates with Convenience Link Tabs)

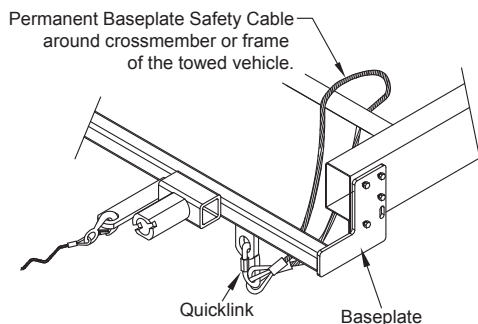

Option #2

(Baseplates with out Convenience Link Tabs)

