



Baseplate Installation Instructions

BX1988
2006-07 Dodge Ram 1500
(2/4WD, Include Sport,
No Mega Cab)
2008 Dodge Ram 1500 Quad St/Sl
Installation Instructions

Serial Number

Please read BOTH these Installation Instructions and the General Instructions before attempting to install or operate this equipment.

- Blue Ox® towing products and accessories are intended to be installed by Blue Ox® Dealers who are familiar with our products and have the equipment necessary and knowledge to do "fit work". When necessary Blue Ox® Dealers can be found at www.blueox.us or by contacting our Customer Care Department at (402) 385-3051 or toll free (888) 425-5382.
- Many Blue Ox® Baseplates are designed to use existing holes and hardware to mount the baseplate to the towed vehicle. Even though bolts are there, do not assume they are adequate for baseplate mounting. Always use hardware supplied in the hardware kit and existing hardware specified in the Baseplate Installation Instructions.

Attachment Tab Height: 24"
 Attachment Tab Width: 18.5"

Bolt Torque Specifications
Torque in Foot-Pounds for Metric Bolts

Bolt Size	Grade 8.8	Grade 10.9
6MM	6	8
8MM	16	22
10MM	31	40
12MM	54	70
14MM	89	117

Confirm the towability and pre-towing procedures for your vehicle with the owner's manual or contact the vehicle's manufacturer for specific towing procedures.

Bolt Torque Specifications
Torque in Foot-Pounds for Inch Bolts

Bolt Size	Grade 5	Grade 8
1/4"	10	14
5/16"	19	29
3/8"	33	47
7/16"	54	78
1/2"	78	119
5/8"	154	230



! WARNING

Failure to read and follow these instructions could result in separation of the towed vehicle from the tow bar, causing property damage, loss of towed vehicle, personal injury or death.

BX1988 2006-07 Dodge Ram 1500 (2/4WD, Include Sport, No Mega Cab) 2008 Dodge Ram 1500 Quad St/Slt Installation Instructions

Parts List

Ref. No.	Qty.	Part #	Description
1	1	61-6663	Weldment, Baseplate, BX1973
2	10	61-4029	1/2-13. Whiz Nut, with 10" Wire
3	10	201-0051	1/2-13 X 1 1/2 Hex Bolt Grd.5, ZP
4	10	203-0012	1/2" Lock Washer. ZP
5	2	201-0553	1/4-20 x 1/2" Hx. Wshd, Type F Screw
6	2	201-0192	10-32 X 1/2 Slot, RD. HD. Screw
7	2	203-0054	#10 Lock Washer
8	2	202-0047	#10-32 Hex Nut
9	2	101-5822	Adapter, 4 Way Connector
10	2	62-3469	Attachment Tab Assy., Rem., SF/LB, 1 Hole
	2	226-0049	Baseplate Safety Cable, 36" CL IV (Not Shown)
	2	229-0512	Quicklink, 1/2, ZP (Not Shown)
	2	290-0437	Cap Plug, Black (Not Shown)

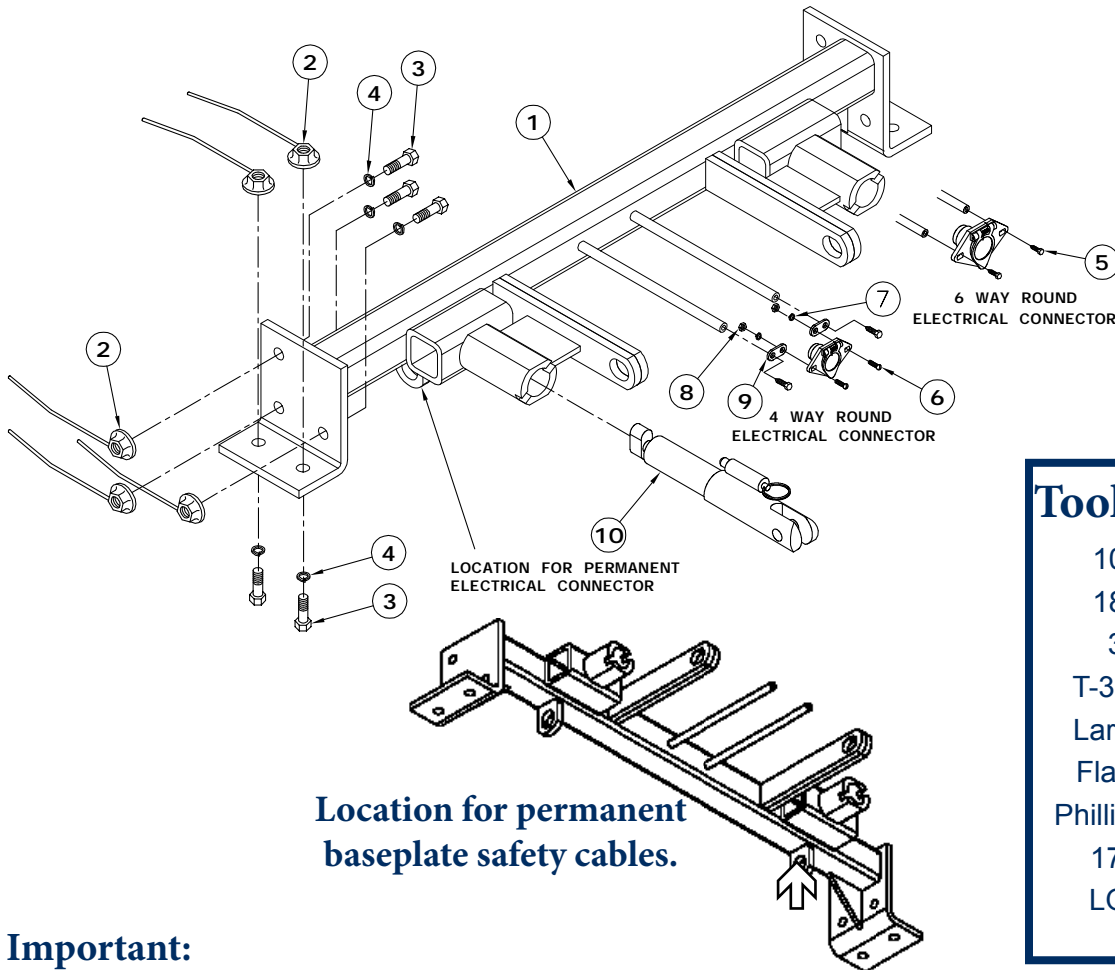

Tools Required

- 10MM Socket
- 18MM Socket
- 3/4" Socket
- T-30 Torx Socket
- Large Vise Grips
- Flat Screwdriver
- Phillips Screwdriver
- 17/32" Drill Bit
- LOCTITE Red

Important:

Use only genuine factory replacement parts on your baseplate. Do NOT substitute homemade or non-typical parts. If a bolt is lost or in need of replacement, for your safety and the preservation of your baseplate, be sure to use a replacement bolt of the same grade (In most cases it will be Grade 5, please reference the parts list above). Replacement parts may be ordered through your nearest Blue Ox® Dealer or Distributor, or call our Customer Care Team at (402)385-3051.

BX1988
2006-07 Dodge Ram 1500
(2/4WD, Include Sport, No Mega Cab)
2008 Dodge Ram 1500 Quad St/Slt
Installation Instructions

Vehicle Weight:

The weight of this vehicle is near the Class III, 5,000 lb rating limitations. Some models, depending upon options, may well exceed this 5,000 lb rating. The 10,000 lb rated Aventa® II or Aventa® LX tow bars must be used for these applications. Tow bar adapters are not to be used with vehicles weighing over 5,000 lbs.

Instructions:

The metal bumper fascia is removed and reinstalled during the baseplate installation. Drilling is required. The plastic insert on the metal bumper will not be reinstalled.

The dimensional variations between otherwise identical vehicles can be considerable. While the baseplate was designed for easy installation, it may be necessary to tailor the baseplate slightly to compensate for auto manufacturer's tolerances. These minor adjustments may include filing a hole slightly, bending electrical rods or bending end plates.

The BX8869 Bulb and Socket Wiring Kit is available for this vehicle.

Installation Instructions:



1. **2008 Model Only:** Using a T-30 Torx socket remove three torx head bolts from the wheel well just forward the front tire. Do this to both sides and set bolts aside for later reinstallation.

The location for the BX8869 Bulb and Socket Wiring Kit.



BX1988
2006-07 Dodge Ram 1500
(2/4WD, Include Sport, No Mega Cab)
2008 Dodge Ram 1500 Quad St/Slt
Installation Instructions



2. Using the Phillips screwdriver, remove the two Phillips head pushpins from the plastic insert on the front of the metal bumper. Do this to both sides of the vehicle. Pull the plastic fascia insert forward to release. Set the pushpins aside to be reinstalled later. Plastic insert will not be reinstalled.



3. On the driver's side, just forward of the front tire, unplug the electrical connection and remove the clip from bumper brace with the flat screwdriver.



4. Remove the four metric hex nuts from the back side of the bumper brace, on the end of the frame rail with the 18MM socket. Do this to both sides of the vehicle. Pull the metal bumper fascia forward and carefully set aside with the hex nuts to be reinstalled later. **CAUTION:** the metal bumper fascia is very heavy and may require two people to remove.



5. Place the baseplate between and up to the bottom of the frame rails. Then slide forward until the baseplate is flush against the back side of the bumper brace of the vehicle and clamp in place with the large vise grips. Using the baseplate as a template, drill two holes in the bottom of the frame rail with the 17/32" drill bit. Do this to both sides of the vehicle. **The baseplate is painted white for illustrative purposes only. The actual baseplate has a durable, black, powder coat finish.**

BX1988
2006-07 Dodge Ram 1500
(2/4WD, Include Sport, No Mega Cab)
2008 Dodge Ram 1500 Quad St/Slt
Installation Instructions

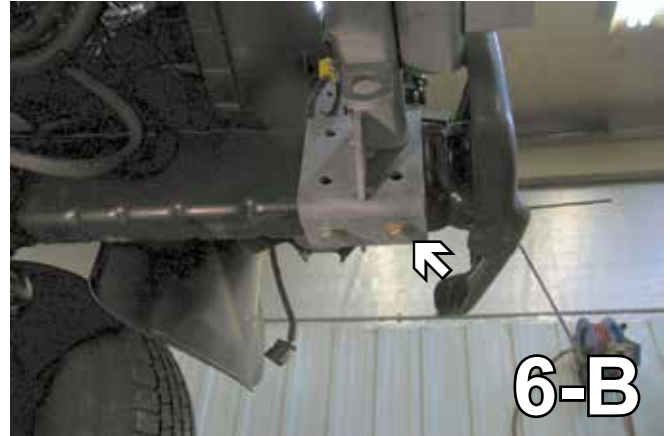

6. Insert 1/2" whiz nut with 10" wire into opening in the frame end to align with the drilled holes. Tighten the 1/2-13 hex bolt and lock washers into whiz nuts from the baseplate side using the 3/4" socket. Do this to both sides of the vehicle.



7. Using the baseplate as a template, drill the three remaining holes with the 17/32" drill bit. Do this to both sides of the vehicle. Insert 1/2" whiz nut with 10" wire into the opening in the frame end to align with the drilled holes. Tighten the 1/2-13 hex bolts and lock washers into the whiz nuts from the baseplate side using the 3/4" socket. Do this to both sides of the vehicle.

8. **This is the attachment location for the permanent baseplate safety cables on the frame rail and the convenience link on the bottom of the baseplate. Do this to both sides of the vehicle.**
9. Reinstall metal bumper fascia with the existing metric hex nuts using the 18MM socket. Install the tow bar and safety cables according to the instructions included in their packages.

BE SURE TO USE LOCTITE® RED ON ALL BOLTS BEFORE TIGHTENING. TIGHTEN ALL BOLTS ACCORDING TO THE TORQUE CHART ON THE FRONT PAGE OF THESE INSTRUCTIONS OR ON PAGE 3 OF THE BASEPLATE TOWING GENERAL INSTRUCTIONS.

Do not substitute other devices if the tow bar pin and clip are lost.

DEALER OR INSTALLER: BE CERTAIN THE USER RECEIVES THE INSTRUCTION SHEETS.

BX1988
2006-07 Dodge Ram 1500
(2/4WD, Include Sport, No Mega Cab)
2008 Dodge Ram 1500 Quad St/Slt
Installation Instructions

CUSTOMER SERVICE COMMITMENT



Blue Ox is committed to providing you with exceptional customer care throughout your lifetime with our products. Our team is here to assist you with any questions you may have regarding the performance of your product. Simply call 1-800-228-9289 and you can speak with our customer care team.

Additionally, please visit our website to see which rallies our Destination America team will be attending. For a nominal fee, our service technician will service your towing system to ensure it's in proper working condition. Also as a commitment to our customers, should you visit our factory you can stay at our full service Blue Ox campground at no charge along with enjoying a factory tour.

Again thank you for being our customer and for the confidence you have shown in the performance of our products. It is because of customers like you we enjoy the success we have today.

If the baseplate is in an accident, it must be replaced. DO NOT use it again! An accident can cause unseen damage and using it again could result in more damage or serious injury. DO NOT use the baseplate if it is damaged or missing parts.



© 2009 Blue Ox
One Mill Road, Industrial Park
Pender, Nebraska 68047
Phone: (402) 385-3051
Toll Free: (888) 425-5382
Fax: (402) 385-3360
www.blueox.us

General Information

1. Ensure that your product(s) are registered online at www.blueox.com. It is crucial to register your product(s) so that you may be alerted of product offerings, updates, upgrades, maintenance and safety bulletins, and/or recalls.
2. **It is the owner's responsibility to inspect all towing equipment for cracked welds, missing or worn parts and loose bolts before each towing trip.** Be sure to use Loctite® Red on all bolts and tighten to the recommended specifications.
3. **It is the owner's responsibility to hook up all towing equipment per manufacturer's instructions/recommendations.**
4. Remove the attachment tabs when not in use (if applicable).

Notice To Baseplate Installer

1. It is YOUR responsibility to watch for:

- Oil cooler and air conditioner lines
- Electrical wires and hoses
- Missing parts or attaching points on the frame

** If the baseplate is improperly installed and is against a wire or hose, it could cause fluid leaks or electrical shorts some time after the actual baseplate installation.

Permanent Baseplate Safety Cable Installation

Permanent baseplate safety cables are strongly recommended when towing a vehicle with a tow bar. The principle function of the permanent baseplate safety cables is to prevent the towed vehicle from breaking loose in the event the connection between the frame of the towed vehicle and the baseplate fails or becomes disconnected. The cables must be connected from the baseplate to the frame rail or cross member of the vehicle's frame. The illustrations below show the possible arrangements recommended by Blue Ox®. Each permanent baseplate safety cable must have an adequate weight rating for the towing system. The weight rating of the two (2) cables together will not qualify.

Do not mount the permanent baseplate safety cables against wires, hoses or brake lines.

These permanent baseplate safety cables should remain installed as long as the baseplate is installed on the vehicle. Permanent baseplate safety cables are to be used in conjunction with, and NOT a replacement for legally required safety cables attaching the towed vehicle to the towing vehicle.

OPTION #1

Permanent Baseplate Safety Cables to Cross Member or Frame of Towed Vehicle.

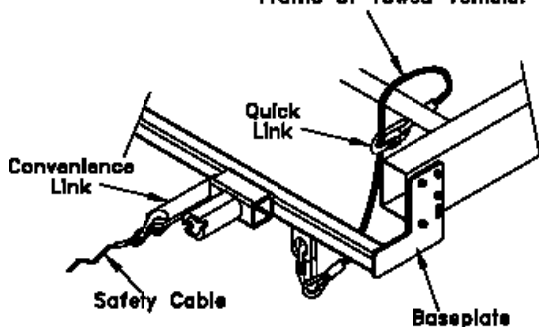

OPTION #2

Permanent Baseplate Safety Cables to Cross Member or Frame of Towed Vehicle.

