



BX1927

# 1995-00 Chrysler Cirrus 1996-00 Chrysler Sebring (Convertible ONLY)

## Serial Number

## Installation Instructions

Attachment Tab Height: 12"  
Attachment Tab Width: 24"

**Please read BOTH these Installation Instructions and the General Instructions before attempting to install or operate this equipment.**

**Bolt Torque Specifications**  
Torque in Foot-Pounds per Metric Bolts

Bolt Size	Grade 8.8	Grade 10.9
6MM	6	8
8MM	16	22
10MM	31	40
12MM	54	70
14MM	89	117

- Blue Ox® towing products and accessories are intended to be installed by Blue Ox® Dealers who are familiar with our products and have the equipment necessary and knowledge to do "fit work". When necessary Blue Ox® Dealers can be found at [www.blueox.us](http://www.blueox.us) or by contacting our 24/7 Customer Care Department at (402) 385-3051 or toll free (888) 425-5382.
- Many Blue Ox® Baseplates are designed to use existing holes and hardware to mount the baseplate to the towed vehicle. Even though bolts are there, do not assume they are adequate for baseplate mounting. Always use hardware supplied in the hardware kit and existing hardware specified in the Baseplate Installation Instructions.

**Bolt Torque Specifications**  
Torque in Foot-Pounds per Inch Bolts

Bolt Size	Grade 5	Grade 8
1/4"	10	14
5/16"	19	29
3/8"	33	47
7/16"	54	78
1/2"	78	119
5/8"	154	230

Confirm the towability and pre-towing procedures for your vehicle with the owner's manual or contact the vehicle's manufacturer for specific towing procedures. You can also contact REMCO for additional information at 1(800)228-2481.

**! WARNING**

Failure to read and follow these instructions could result in separation of the towed vehicle from the tow bar, causing property damage, loss of towed vehicle, personal injury or death.

BX1927

# 1995-00 Chrysler Cirrus 1996-00 Chrysler Sebring (Convertible ONLY) Installation Instructions

## Parts List

Ref. No.	Qty.	Part #	Description
1	1	61-4829	Weldment, Baseplate, BX1927
2	2	61-5527	1/2-13 x 1" Hex Bolt, 1" x 2" Plate, with Wire
3	2	202-0005	1/2-13 Nut, Hex, ZP
4	2	201-0368	3/8-16 x 1 1/4" Hex Bolt, Grd. 5
5	2	202-0003	3/8-16 Hex Nut
6	2	203-0010	3/8" Lock Washer
7	2	203-0012	1/2" Lock Washer
E	2		Existing Bolts

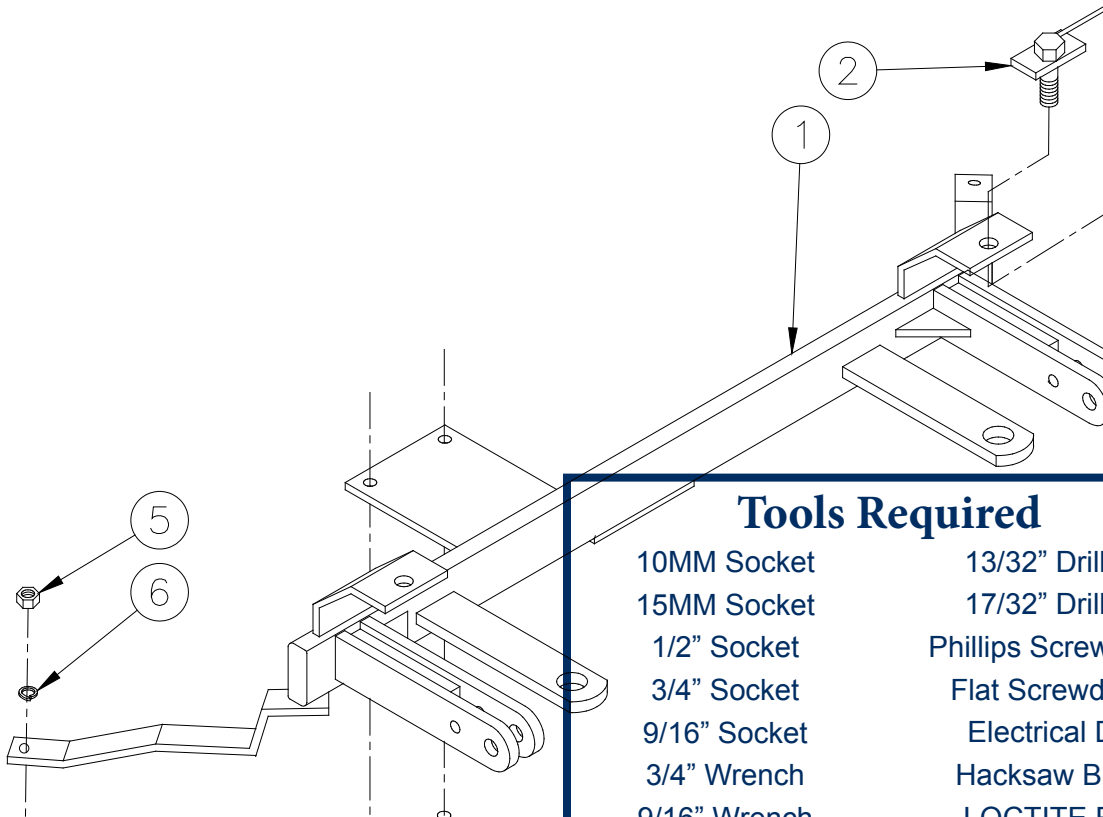

## Tools Required

10MM Socket	13/32" Drill Bit
15MM Socket	17/32" Drill Bit
1/2" Socket	Phillips Screwdriver
3/4" Socket	Flat Screwdriver
9/16" Socket	Electrical Drill
3/4" Wrench	Hacksaw Blade
9/16" Wrench	LOCTITE Red

### Important:

Use only genuine factory replacement parts on your baseplate. Do NOT substitute homemade or non-typical parts. If a bolt is lost or in need of replacement, for your safety and the preservation of your baseplate, be sure to use a replacement bolt of the same grade (In most cases it will be Grade 5, please reference the parts list above). Replacement parts may be ordered through your nearest Blue Ox® Dealer or Distributor, or call our 24/7 Customer Care Team at (402)385-3051.

BX1927

# 1995-00 Chrysler Cirrus 1996-00 Chrysler Sebring (Convertible ONLY) Installation Instructions

## Standard Tab Spacing Guidelines:

To use certain adapters or a RangeFinder II tow bar in conjunction with standard tab baseplates an additional 5/16" hole must be drilled in the attachment tabs. The Ambassador tow bar will require an adapter for attachment tabs that are not 24" wide. The Adventurer tow bar will require an adapter for attachment tabs that are less than 24" wide. The Acclaim tow bar will not fold and store without the use of an adapter on vehicles with attachment tabs less than 24" wide. The BX88151 adapter cannot be used with this baseplate.

## Instructions:

**Installation of the baseplate requires removing and reinstalling the bumper. Drilling is required. The bumper opening behind the license plate mount will need to be trimmed.**

**The dimensional variations between otherwise identical vehicles can be considerable. While the baseplate was designed for easy installation, it may be necessary to tailor the baseplate slightly to compensate for auto manufacturer's tolerances. These minor adjustments may include filing a hole slightly, bending electrical rods, and/ or bending end plates.**

## Installation Instructions

1. Read the Baseplate General Instructions Sheet included with this baseplate.
2. The baseplate bolts to the car using six existing bolts. It mounts to the center engine mount, the bottom of the metal inner bumper and the frame, forward of the tie down brackets.
3. The bumper must be removed to install the baseplate. Remove the bolts or rivets along the top of the bumper and the bottom of the bumper. There are also bolts in each fender (where the quarter panel and the bumper molding are connected). **NOTE: It will be easier to remove the bolts that connect the quarter panels and the bumper moldings if the headlights are removed first.** With the rivets and bolts removed, the bumper can be pulled forward and removed. If there are driving lights, the sockets will have to be removed from the light to complete the removal of the bumper.
4. There are four bolts under the center of the radiator mount. The front two will be used for the center brace of the baseplate. Remove the front two bolts and bolt up the center mount of the baseplate. Snug the bolts, but do not tighten completely yet.
5. The upper braces will fit against the bottom of the metal main bumper. Clamp the upper braces to the main bumper and mark their locations, remove the baseplate and drill 17/32" holes in the bottom of the bumper.

BX1927

# 1995-00 Chrysler Cirrus 1996-00 Chrysler Sebring (Convertible ONLY) Installation Instructions

6. Remount the baseplate to the center mounting area. The upper braces use the 1/2" x 1 1/4" bolt plate with wire and the bumper bolts. Slide the bolt plate in from the end of the bumper on each end. Use the lock washer and 1/2" nuts. Be sure to use LOCTITE Red on each bolt to ensure the bolts will not loosen while in use. When these four bolts are started, Tighten completely.
7. The lower braces bolt to the flange on the frame, just ahead of the tie down bracket. Clamp the mounts to the flange and use the mounts as a template to drill the 13/32" holes. Bolt the mount to the flange with the 3/8" x 1 1/4" bolts, lock washers, and nuts provided. Be sure to apply LOCTITE Red to each bolt.
8. The bumper opening behind the license plate mount will need to be trimmed to allow the attachment tabs to protrude. Hold the bumper up in position to mark where it will need to be trimmed. Start a small and enlarge the holes as needed for the best results.
9. If necessary the convenience links can be bent down to clear the bumper molding.

Install the tow bar and safety cables according to the instructions included in their packages.

Do not substitute other devices if the tow bar pin and clip are lost.

**DEALER OR INSTALLER: BE CERTAIN THE USER RECEIVES THE INSTRUCTION SHEETS.**

## Customer Service Commitment

Blue Ox® is focused on providing exemplary customer service, as observed in our mission statement and guiding principles. In accordance with this objective, Blue Ox® is proud to provide services such as repairs and general maintenance of Blue Ox® products at over 150 RV Rallies.

Look for our Destination America or Blue Ox® Racing service crews at the next rally or NASCAR race that you attend. If you were not present, you will find an informative, personalized note explaining any services that may have been performed to your Blue Ox® products.

Blue Ox® also offers educational seminars at rallies and through our Parks and Resort teams. In addition, Blue Ox® customers visiting our factory may take advantage of the well-equipped Blue Ox® RV park at no charge to you, our valued and appreciated customer.



© 2006 Blue Ox  
One Mill Road, Industrial Park  
Pender, Nebraska 68047  
Phone: (402) 385-3051  
Toll Free: (888) 425-5382  
Fax: (402) 385-3360  
www.blueox.us  
292-1955

# General Information

1. Ensure that your product(s) are registered online at [www.blueox.com](http://www.blueox.com). It is crucial to register your product(s) so that you may be alerted of product offerings, updates, upgrades, maintenance and safety bulletins, and/or recalls.
2. **It is the owner's responsibility to inspect all towing equipment for cracked welds, missing or worn parts and loose bolts before each towing trip.** Be sure to use Loctite® Red on all bolts and tighten to the recommended specifications.
3. **It is the owner's responsibility to hook up all towing equipment per manufacturer's instructions/recommendations.**
4. Remove the attachment tabs when not in use (if applicable).

## Notice To Baseplate Installer

### 1. It is YOUR responsibility to watch for:

- Oil cooler and air conditioner lines
- Electrical wires and hoses
- Missing parts or attaching points on the frame

\*\* If the baseplate is improperly installed and is against a wire or hose, it could cause fluid leaks or electrical shorts some time after the actual baseplate installation.

## Permanent Baseplate Safety Cable Installation

Permanent baseplate safety cables are strongly recommended when towing a vehicle with a tow bar. The principle function of the permanent baseplate safety cables is to prevent the towed vehicle from breaking loose in the event the connection between the frame of the towed vehicle and the baseplate fails or becomes disconnected. The cables must be connected from the baseplate to the frame rail or cross member of the vehicle's frame. The illustrations below show the possible arrangements recommended by Blue Ox®. Each permanent baseplate safety cable must have an adequate weight rating for the towing system. The weight rating of the two (2) cables together will not qualify.

***Do not mount the permanent baseplate safety cables against wires, hoses or brake lines.***

These permanent baseplate safety cables should remain installed as long as the baseplate is installed on the vehicle. Permanent baseplate safety cables are to be used in conjunction with, and NOT a replacement for legally required safety cables attaching the towed vehicle to the towing vehicle.

### OPTION #1

Permanent Baseplate Safety Cables to Cross Member or Frame of Towed Vehicle.

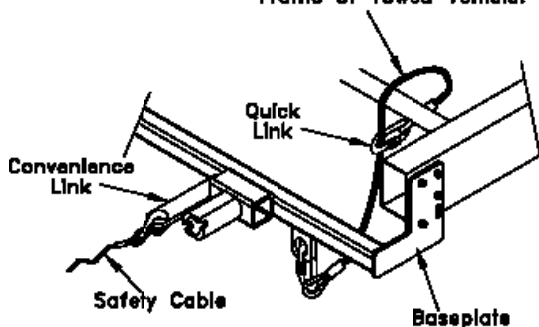

### OPTION #2

Permanent Baseplate Safety Cables to Cross Member or Frame of Towed Vehicle.

