

BLUE OX®

Baseplates

BX1665

2005-06 Chevy SSR

Installation Instructions

Serial Number

Please read BOTH these Installation Instructions and the General Instructions before attempting to install or operate this equipment.

- Blue Ox® towing products and accessories are intended to be installed by Blue Ox® Dealers who are familiar with our products and have the necessary equipment and knowledge to do "fit work". When necessary Blue Ox® Dealers can be found at www.blueox.us or by contacting our 24/7 Customer Care Department at (402) 385-3051 or toll free at (888) 425-5382.
- Many Blue Ox® baseplates are designed to use existing holes and hardware to mount the baseplate to the towed vehicle. Even though bolts are there, do not assume they are adequate for baseplate mounting. Always use hardware supplied in the hardware kit and existing hardware specified in the Baseplate Installation Instructions.

Attachment Tab Height: 18"
Attachment Tab Width: 24 3/4"

Bolt Torque Specifications
Torque in Foot-Pounds per Metric Bolts

Bolt Size	Grade 8.8	Grade 10.9
6MM	6	8
8MM	16	22
10MM	31	40
12MM	54	70
14MM	89	117

Confirm the towability and pre-towing procedures for your vehicle with the owner's manual or contact the vehicle's manufacturer for specific towing procedures. You can also contact REMCO for additional information at 1(800)228-2481.

Bolt Torque Specifications
Torque in Foot-Pounds per Inch Bolts

Bolt Size	Grade 5	Grade 8
1/4"	10	14
5/16"	19	29
3/8"	33	47
7/16"	54	78
1/2"	78	119
5/8"	154	230



! WARNING

Failure to read and follow these instructions could result in separation of the towed vehicle from the tow bar, causing property damage, loss of towed vehicle, personal injury or death.

BX1665 2005-06 Chevy SSR Installation Instructions

Parts List

Ref.No.	Qty.	Part #	Description
1	1	61-6173	Weldment, Baseplate, BX1665
2	4	61-5208	Weldment, 3/8-16 Nut Plate, w/ 14" Wire
3	4	201-0440	3/8-16 x 1 1/2" Hex Bolt, Grade 5, ZP
4	4	203-0010	3/8" Lock Washer, ZP
5	4	203-0003	3/8" Flat Washer, ZP
6	4	201-0428	10MM-1.5 x 50MM Hex Bolt, Grade 8.8, ZP
7	4	203-0104	10MM Lock Washer, ZP
8	2	201-0979	#12-14 x 1" Self Drilling Screw, ZP
9	2	201-0192	#10-32 x 1/2" Slot, Rd Hd. Screw
10	2	203-0054	#10 Lock Washer
11	2	202-0047	#10-32 Hex Nut
12	2	101-5822	Adapter, 4 Way Connector
13	2	62-3468	Attachment, Assembly, SF/SB (R)
14	1	102-5658	Shim Plate
15	2	290-0437	Cap Plug (Not Shown)

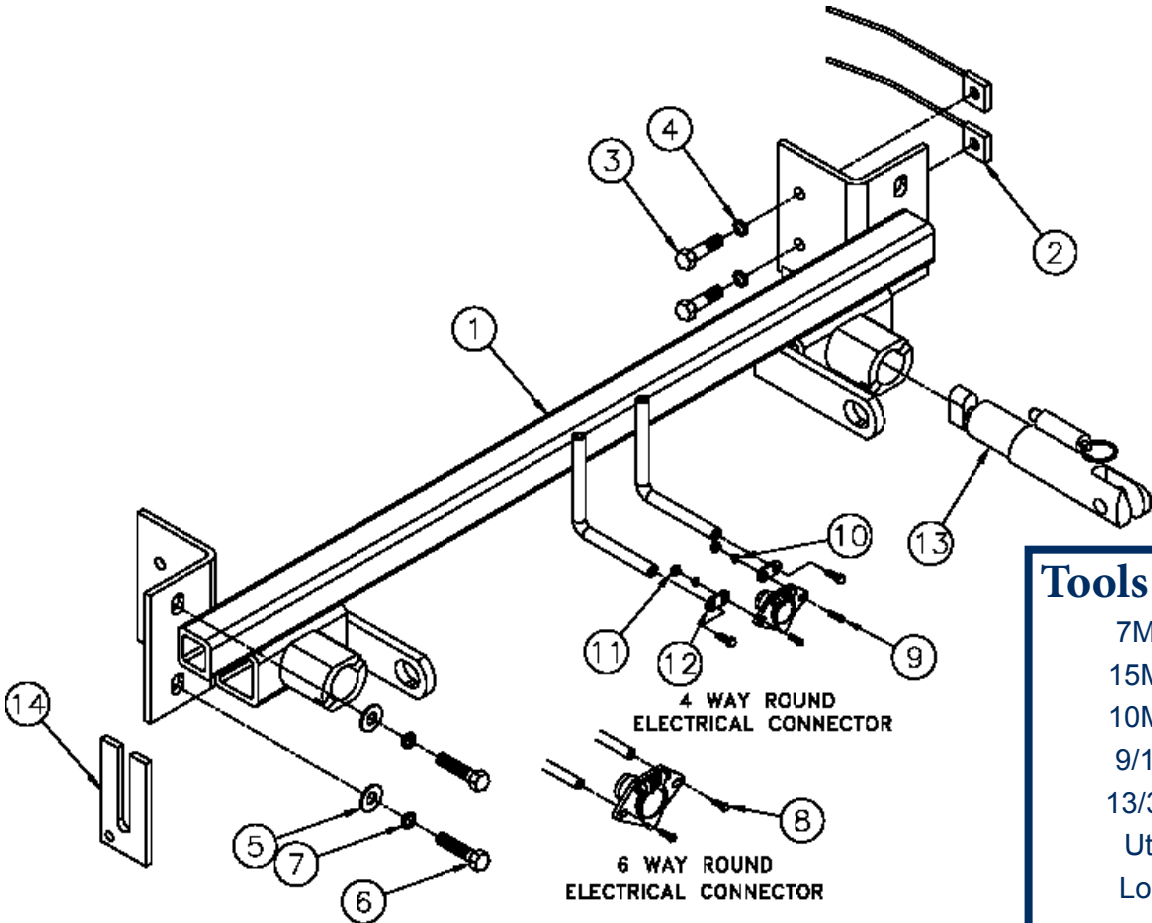

- ### Tools Required
- 7MM Socket
 - 15MM Socket
 - 10MM Socket
 - 9/16" Socket
 - 13/32" Drill Bit
 - Utility Knife
 - Loctite RED

Important:

Use only genuine factory replacement parts on your baseplate. Do NOT substitute homemade or non-typical parts. If a bolt is lost or in need of replacement, for your safety and the preservation of your baseplate, be sure to use a replacement bolt of the same grade. In most cases it will be Grade 5-please reference the parts list above. Replacement parts may be ordered through your nearest Blue Ox® dealer or distributor, or call our 24/7 Customer Care Team at (402)385-3051 or toll free (888) 425-5382.

BX1665

2005-06 Chevy SSR

Installation Instructions

Vehicle Weight:

The weight of this vehicle is near the Class III, 5,000lb rating limitations. Some models, depending on options, may well exceed this 5,000lb rating. The 10,000 lb rated Aventa® II or Aventa® LX tow bars must be used for these applications. Tow bar adapters are not to be used with this baseplate.

Instructions:

The front fascia is removed and reinstalled during baseplate installation. The metal bumper is removed and not reinstalled. Drilling is required. Trimming or removal of the lower grille is necessary.

The dimensional variations between otherwise identical vehicles can be considerable. Although the baseplate was designed for easy installation, it may be necessary to tailor the baseplate slightly to compensate for auto manufacturer's tolerances. These minor adjustments may include filing a hole slightly, bending electrical rods, and/or bending end plates.

The BX8869 Bulb and Socket Wiring Kit is recommended for this vehicle.



1. Using a 7MM socket, remove two metric bolts from silver plastic piece that rests on the top of the fascia. Pull this plastic forward and set it aside with bolts to be reinstalled later.



2. Using the 10MM socket, remove the nut next to the headlight assembly. Do this to both sides of the vehicle. Set nuts aside to be reinstalled later.



3. Using the 10MM socket remove 2 metric bolts from the top of the fascia.

BX1665

2005-06 Chevy SSR

Installation Instructions



4. Using the 7MM socket, remove two metric bolts just forward of the front tire, inside the wheel well. Do this to both sides of the vehicle. Set bolts aside to be reinstalled later.



5. Pull wheel well cover back to expose one metric bolt. To be removed with a 10MM socket to remove it. Do this to both sides of the vehicle. Set bolts aside to be reinstalled later.



6. Remove two push pins on the lower edge of the fascia, just forward of the front tire. Do this to both sides of vehicle. Set push pins aside to be reinstalled later.



7. Using a 10MM socket, remove three metric bolts from underneath the fascia. Do this to both sides of the vehicle. Pull forward on the front fascia to remove. Set bolts and fascia aside to be reinstalled.

BX1665

2005-06 Chevy SSR

Installation Instructions

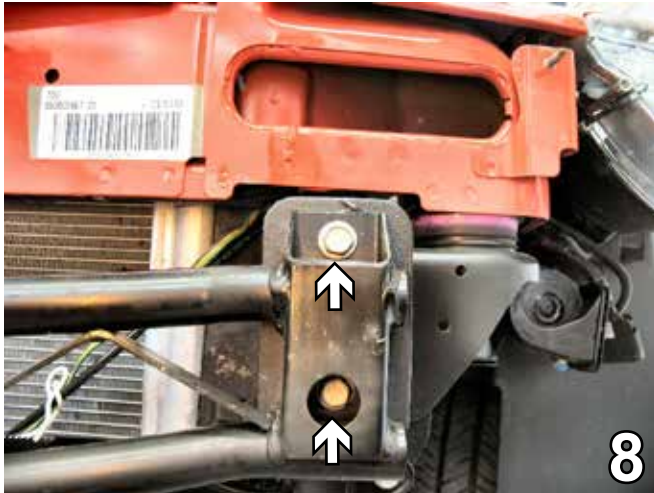

8. Using a 15MM socket, remove two metric bolts from the metal bumper. Do this to both sides of the vehicle. Pull metal bumper forward and set aside with the bolts to be reinstalled later.



9. Align the baseplate so that it is flush with the top of the frame rail and slide completely to one side of the frame rail.

NOTE: If there is gap of 1/4" or more on the opposite side, you will need to install the optional shim plate (see Steps 11-13).

- I If there is less than 1/4" gap, re-center the baseplate and skip Steps 10-13. Using a 10MM socket, install the 10MM hex bolts, 10MM lock washers and 3/8" flat washers to the existing metal bumper bolt holes.

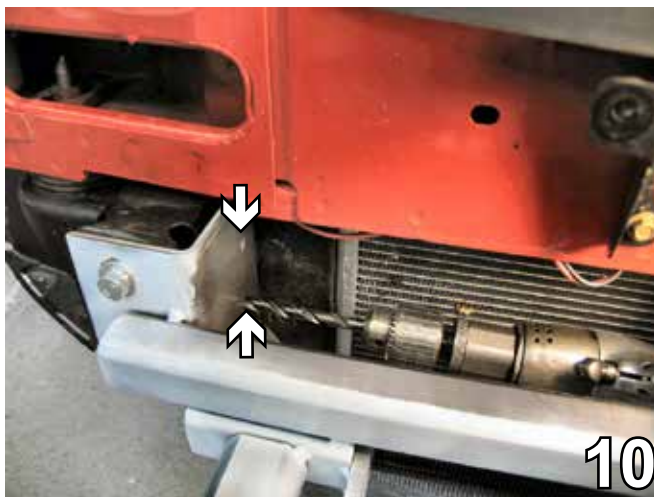

10. Using the baseplate as a template, Drill out the remaining tow holes in the side of the frame rail with the 13/32" drill bit. Insert the 3/8-16 nut plates through the bottom of the frame rail, behind the horn, and align with drilled holes. Install the 3/8-16 x 1 1/2" hex bolts and 3/8" lock washers to the nut plates. If the shim plate is needed do NOT fully tighten the bolts.

****BE SURE TO USE LOCTITE® RED ON ALL BOLTS BEFORE TIGHTENING. TIGHTEN ALL BOLTS ACCORDING TO THE TORQUE CHART ON THE FRONT PAGE OF THESE INSTRUCTIONS OR ON PAGE 3 OF THE BASEPLATE TOWING GENERAL INSTRUCTIONS.**

The baseplate is painted white for illustrative purposes only. The actual baseplate has a powder coat black finish.

BX1665

2005-06 Chevy SSR

Installation Instructions



11. Using a 10MM socket, remove the bolt securing the coolant tubing. Do this to both sides of the vehicle. Remove the tubing and set aside to be reinstalled later. This will allow you to access the frame rail to install the shim plates.



12. Shim plate installation. Slide the shim plate up and inside the space between the frame rail and the baseplate end plate. Tighten the bolts onto the side of the frame rail. Do this to both sides of the vehicle.

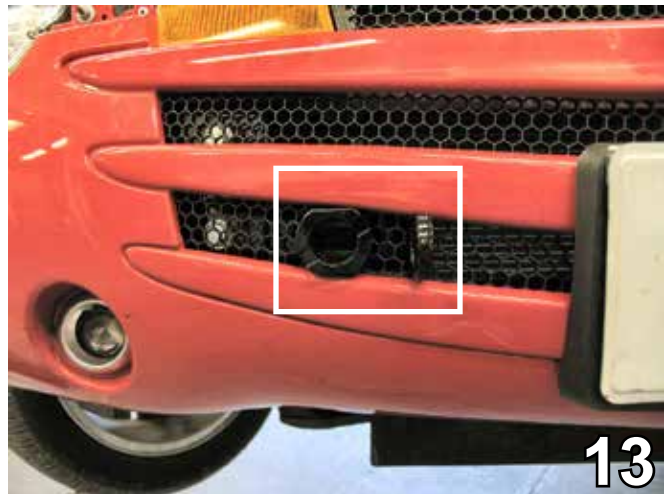

13. Align the fascia to its original position and using a utility knife, trim necessary openings in the grille for the attachment tabs and convenience links.

NOTE: It is not necessary to cut the fascia, you may also remove six clips from the back side of the fascia, slide the bottom grille panel forward and remove it.

Be sure that ALL electrical connections are plugged in properly and functioning BEFORE installing the fascia.

BX1665

2005-06 Chevy SSR

Installation Instructions



14. Adjust the electrical rods behind the license plate as needed to fit through the openings.

15. Reinstall front fascia, inserting all screws, push pins and bolts.
16. The baseplate installation is now complete.
17. Install the tow bar and safety cables according to the instructions provided in their packages. When demonstrating this to the customer, be sure to include all the contents and packages.
18. Do **NOT** substitute other devices if the tow bar pins and clips are misplaced.

DEALER or INSTALLER:
Be certain the user receives all of the technical documentation for all of their products.

BX1665

2005-06 Chevy SSR

Installation Instructions

Customer Service Commitment

Blue Ox® is focused on providing exemplary customer service, as observed in our mission statement and guiding principles. In accordance with this objective, Blue Ox® is proud to provide services such as repairs and general maintenance of Blue Ox® products at over 150 RV Rallies. Look for our Destination America or Blue Ox® Racing service crews at the next rally or NASCAR race that you attend. If you were not present, you will find an informative, personalized note explaining any services that may have been performed to your Blue Ox® products.

Blue Ox® also offers educational seminars at rallies and through our Park and Resort teams. In addition, Blue Ox® customers visiting our factory may take advantage of the well-equipped Blue Ox® RV park at no charge to you, our valued and appreciated customer.



With removable tabs installed.



With Cap Plugs installed.



© 2005, 2006 Blue Ox
One Mill Road, Industrial Park
Pender, Nebraska 68047
Phone: (402) 385-3051
Toll Free: (888) 425-5382
Fax: (402) 385-3360
www.blueox.us
292-2772

General Information

1. Ensure that your product(s) are registered online at www.blueox.com. It is crucial to register your product(s) so that you may be alerted of product offerings, updates, upgrades, maintenance and safety bulletins, and/or recalls.
2. **It is the owner's responsibility to inspect all towing equipment for cracked welds, missing or worn parts and loose bolts before each towing trip.** Be sure to use Loctite® Red on all bolts and tighten to the recommended specifications.
3. **It is the owner's responsibility to hook up all towing equipment per manufacturer's instructions/recommendations.**
4. Remove the attachment tabs when not in use (if applicable).

Notice To Baseplate Installer

1. It is YOUR responsibility to watch for:

- Oil cooler and air conditioner lines
- Electrical wires and hoses
- Missing parts or attaching points on the frame

** If the baseplate is improperly installed and is against a wire or hose, it could cause fluid leaks or electrical shorts some time after the actual baseplate installation.

Permanent Baseplate Safety Cable Installation

Permanent baseplate safety cables are strongly recommended when towing a vehicle with a tow bar. The principle function of the permanent baseplate safety cables is to prevent the towed vehicle from breaking loose in the event the connection between the frame of the towed vehicle and the baseplate fails or becomes disconnected. The cables must be connected from the baseplate to the frame rail or cross member of the vehicle's frame. The illustrations below show the possible arrangements recommended by Blue Ox®. Each permanent baseplate safety cable must have an adequate weight rating for the towing system. The weight rating of the two (2) cables together will not qualify.

Do not mount the permanent baseplate safety cables against wires, hoses or brake lines.

These permanent baseplate safety cables should remain installed as long as the baseplate is installed on the vehicle. Permanent baseplate safety cables are to be used in conjunction with, and NOT a replacement for legally required safety cables attaching the towed vehicle to the towing vehicle.

OPTION #1

Permanent Baseplate Safety Cables to Cross Member or Frame of Towed Vehicle.

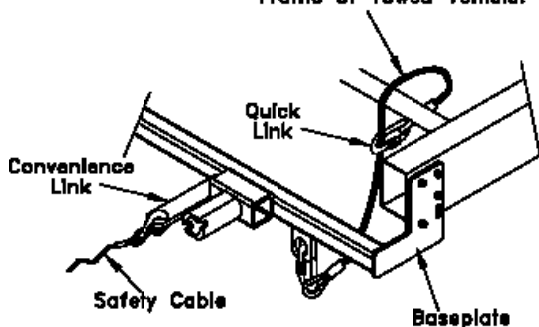

OPTION #2

Permanent Baseplate Safety Cables to Cross Member or Frame of Towed Vehicle.

